



ESI (Ultra) Unitary Service Manual

Contents

- 1. **General Information**----- 2
- 2. **ESI (Ultra) Unitary System**----- 3
 - 2.1 Refrigerant Circuit----- 3
 - 2.2 Function and Control----- 7
 - 2.3 Field Setting----- 17
- 3. **Trouble Shooting**----- 25
 - 3.1 Issues without codes ----- 25
 - 3.2 Error codes list ----- 32
- 4. **Parts List**----- 58
- 5. **Appendix**----- 60
 - 5.1 Sensor Characteristics----- 60
 - 5.2 Wiring Diagram----- 64



All phases of this installation must comply with National, State and Local Codes.

IMPORTANT

These instructions do not cover all variations in systems or provide for every possible contingency to be met in connection with installing and servicing. Should further information be desired or should particular problems arise which are not covered sufficiently for the purchaser’s purposes, the matter should be referred to local distributor.



1 General Information

Condensing Unit	E	OD	A	18	H	-	4860
	1	2	3	4	5		6
Brand E: Ecoer							
Product Series OD: Outdoor Condensing Unit							
Model Letters A: 208/230V-1Ph-60Hz							
SEER 18: 18SEER Series							
Type H: Heat Pump C: AC only							
Capacity 2436: up to 3Ton; 4860: up to 5Ton.							

E series Air Handler	E	AH	A	T	N	-	36
	1	2	3	4	5		6
Brand E: Ecoer							
Product Series AH: Indoor Air Handler							
Model Letters A: 208/230V-1Ph-60Hz							
Metering device T: TXV							
Communications N: 24V Normal							
Capacity 24=24000BTU/h=2Ton; 36=36000BTU/h=3Ton; 48=48000BTU/h=4Ton; 60=60000BTU/h=5Ton.							

2 ESI (Ultra) Unitary System

2.1 Refrigerant Circuit

2.1.1 Functional Parts Layout of Condensing Units

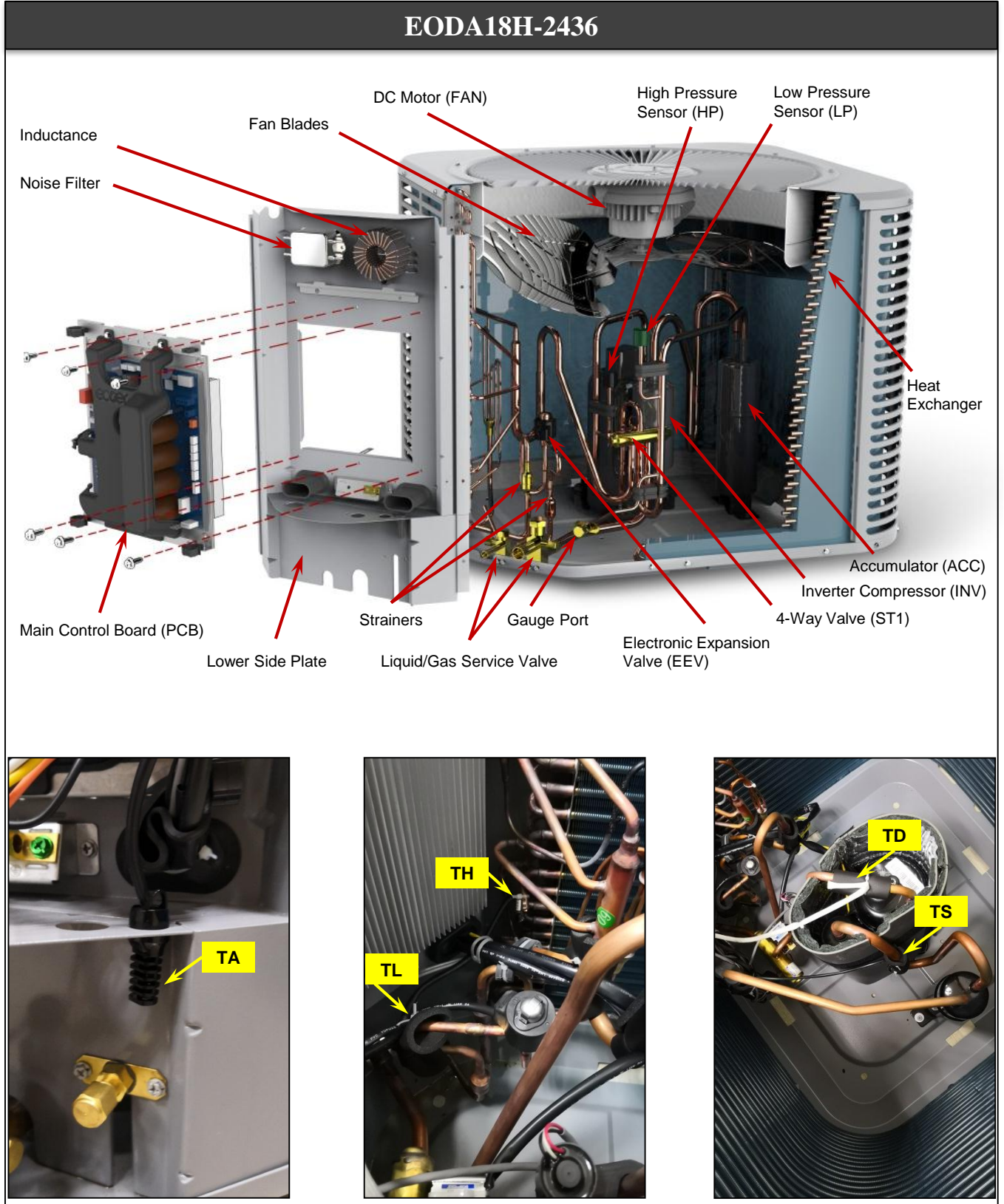

EODA18H-4860

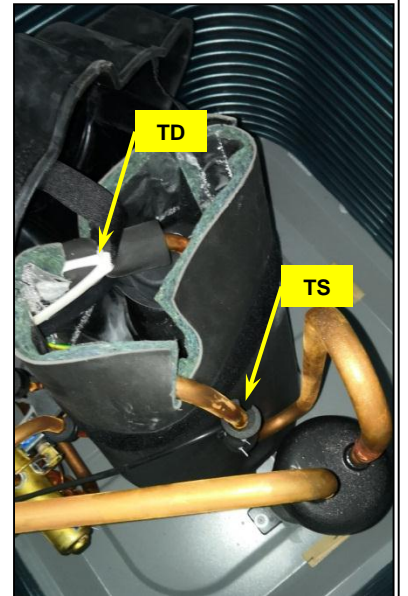
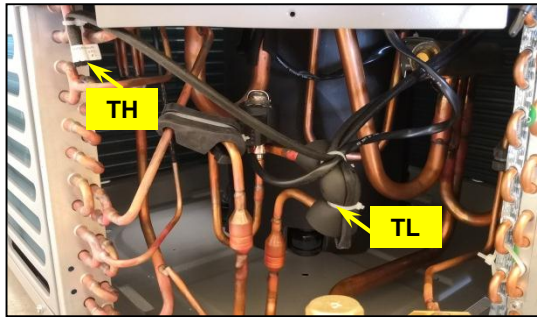
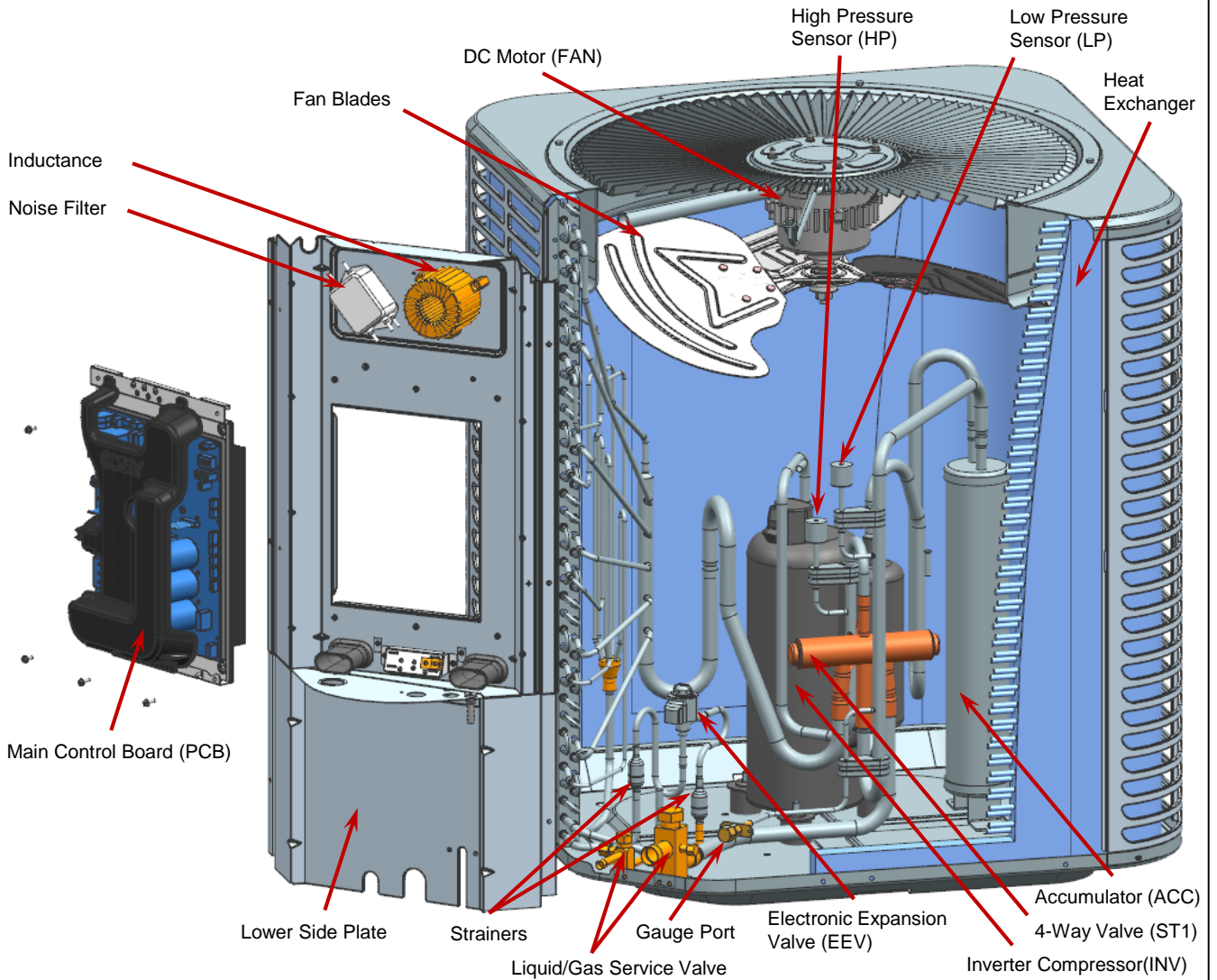

TIPS:
 Remove 5 screws to take away the lower side plate to access TH/TL sensor.
 A slotted screwdriver may be required to open the plate from the condensing unit.

2.1.2 Major Components Functions and Refrigerant Circuits Diagram

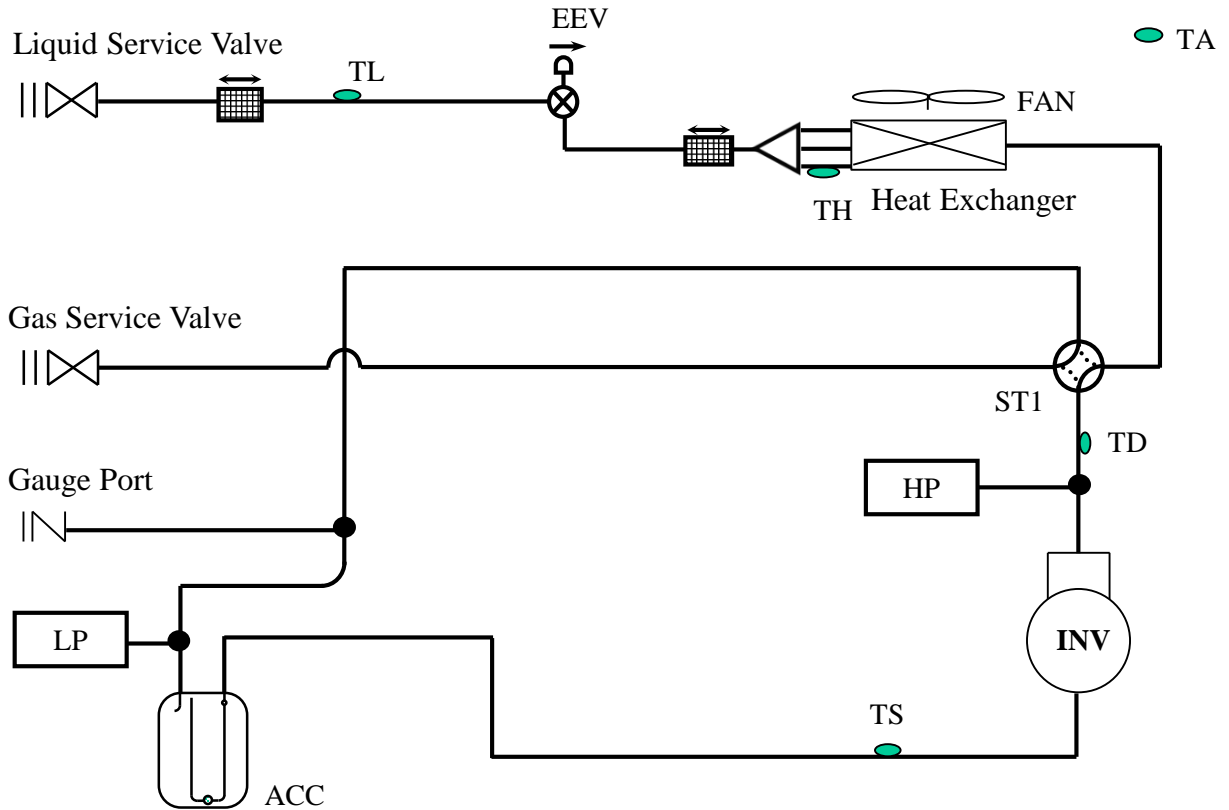

Name	Symbol	Function
Inverter compressor	INV	Adjusts refrigerant flow rate by changing the speed (RPS) based on objective pressure.
DC motor	FAN	Outputs heat exchanger capacity by adjusting the motor rotation speed based on operating pressure.
Electronic expansion valve	EEV	1) Fully open during cooling mode and defrost operation. 2) Control compressor discharge superheat in heating mode.
Reversing valve	ST1	Switches the operation mode between heating and cooling (including defrost control).
Temperature sensor	TH	Uses to control defrosting during heating operation.
	TA	Uses to detect outdoor air temperature and control fan speed.
	TS	Uses to detect compressor suction temperature and calculate compressor suction superheat (SH).
	TL	Uses to detect liquid line temperature and calculate sub-cooling (SC).
	TD	Uses to detect compressor discharge temperature and calculate compressor discharge superheat (DSH).
	TF	Uses to detect heat sink temperature of inverter module.
High pressure sensor	HP	Uses to detect high pressure.
Low pressure sensor	LP	Uses to detect low pressure.
Accumulator	ACC	Uses to store excess refrigerant.

2.1.3 Refrigerant Flow of Each Operation Mode

Cooling Operation (including defrost operation and cooling oil return)

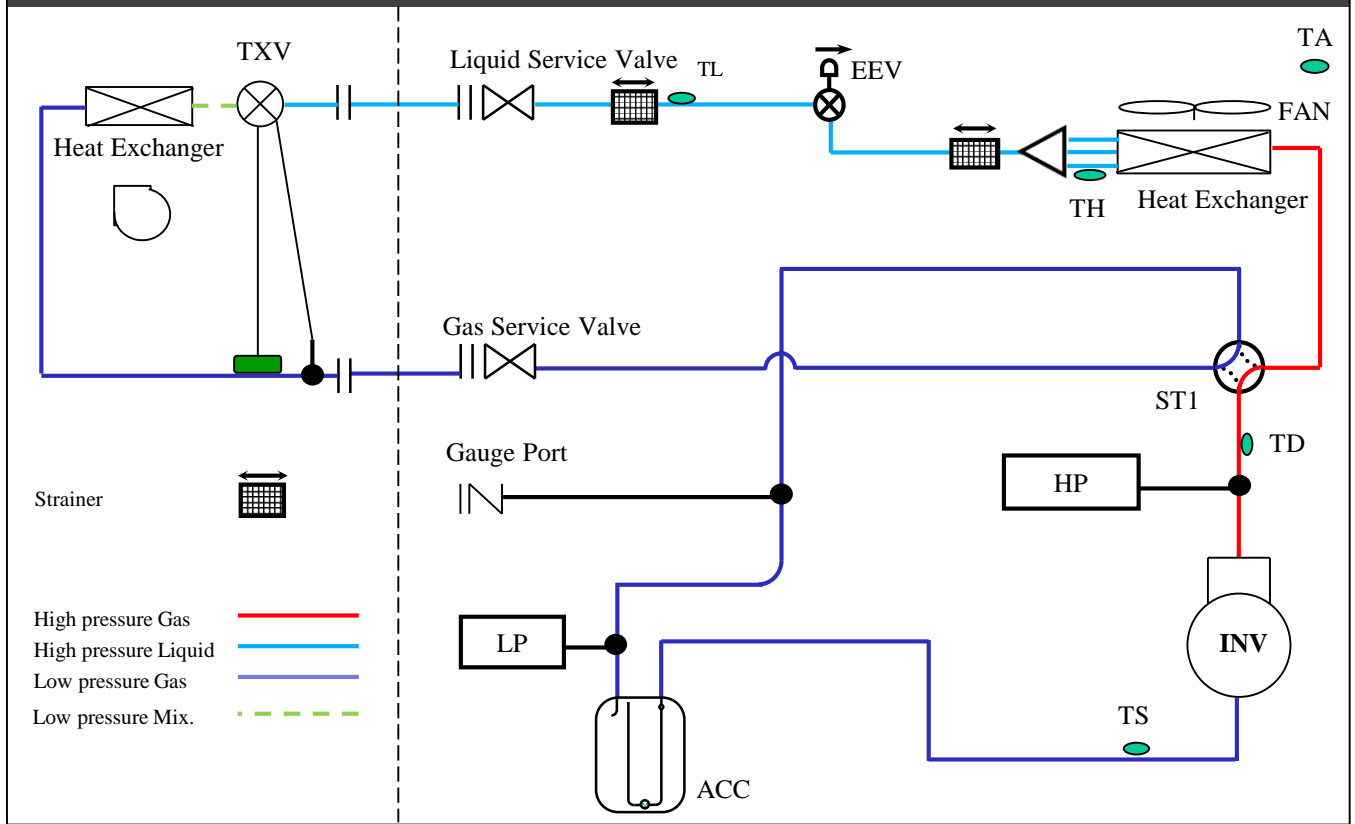

Heating Operation (including heating oil return)

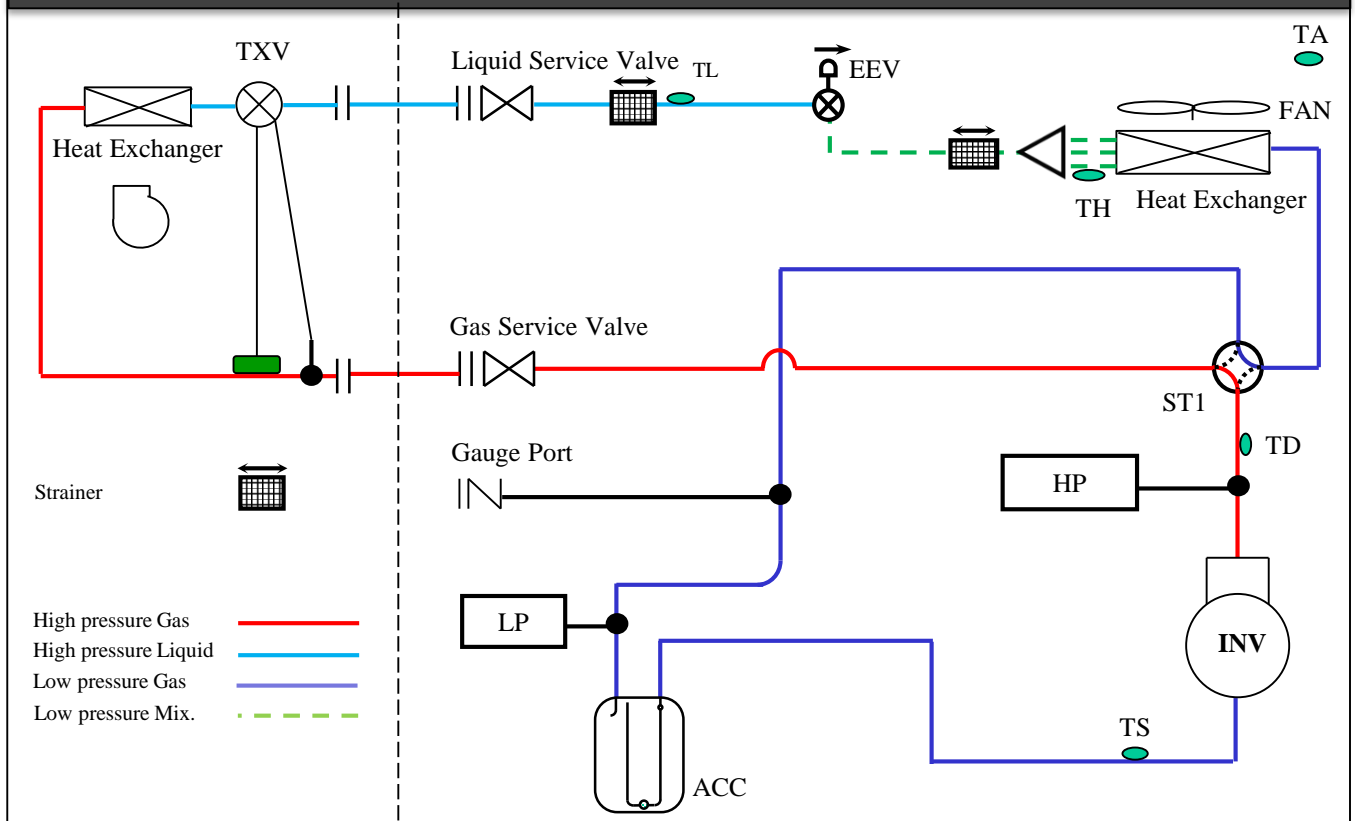

2.2 Function and Control

2.2.1 Operation Mode

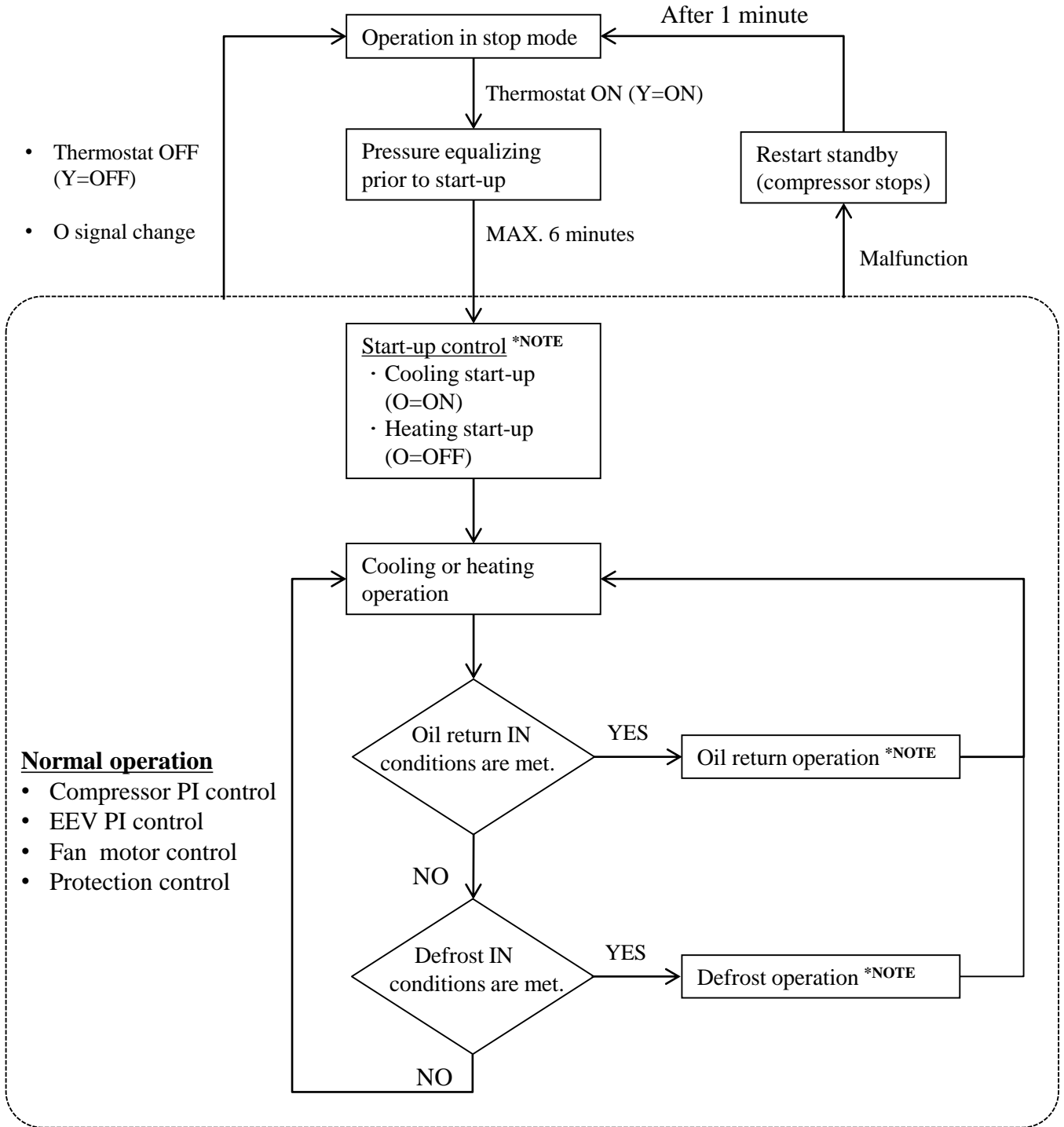

Remarks:

The operation may be enforced to complete under some conditions.

2.2.2 Basic control

2.2.2.1 Normal control

Input Signal	Actuator	Cooling control (including cooling oil return)	Heating control (including heating oil return)
Y	Compressor (INV)	Apply Compressor PI control to maintain T_{es}^{*1}	Apply Compressor PI control to maintain T_{cs}^{*1}
Y/O	Outdoor fan (FAN)	Cooling fan control	Heating fan control
O*2	Reversing valve (ST1)	De-energized	Energized (208/230Vac)
Y/O	Electronic expansion valve (EEV)	480pls	PI control to maintain discharge superheat (DSH)

Remarks:

- Tes: Target Te value (Varies depending on load of the space, mode choice, silent setting, etc.)
 Te: Low pressure equivalent saturation temperature (°F)
 Tcs: Target Tc value (Varies depending on load of the space, mode choice, silent setting, etc.)
 Tc: High pressure equivalent saturation temperature (°F)
- SW1_3=OFF (factory), condensing unit uses Y/C/O (O for cooling) signal to operate heat pump function.
 SW1_3=ON has been set, condensing unit uses Y/C signal to run cooling only.

2.2.2.2 Defrost control

This system carries out demand defrost control if any one of the following conditions satisfy.

- The calculated temperature difference between ambient temperature (TA) and defrost temperature (TH) is called Delta T. After Delta T is achieved and continues for 5 minutes.
 - $41^{\circ}\text{F} < \text{TA} < 59^{\circ}\text{F}$, $\text{TH} \leq 30^{\circ}\text{F}$, $\text{Delta T} = 18^{\circ}\text{F}$
 - $19^{\circ}\text{F} \leq \text{TA} \leq 41^{\circ}\text{F}$, $\text{TH} \leq 30^{\circ}\text{F}$, $\text{Delta T} = 12 \sim 18^{\circ}\text{F}$
 - $\text{TA} < 19^{\circ}\text{F}$, $\text{TH} < 9^{\circ}\text{F}$, accumulative compressor run time ≥ 80 minutes
 TH backup running, $\text{TA} < 59^{\circ}\text{F}$ and $\text{LP} \leq 90\text{psi}$, accumulative compressor run time ≥ 60 minutes
- After "Minimum Run Time" (MRT) is achieved.
 - MRT is 3.5 hours when $\text{TA} < 23^{\circ}\text{F}$
 - MRT is 2 hours when $23^{\circ}\text{F} \leq \text{TA} < 43^{\circ}\text{F}$
- The high pressure drops below 245psi for 20 minutes when $14^{\circ}\text{F} \leq \text{TA} \leq 28^{\circ}\text{F}$.
- Manual defrosting can be chosen from n08 setting (forced defrost).
 Start-up control is enforced to complete, then wait another 5 minutes to activate the defrost operation.

Defrost will be terminated once defrost temperature sensor (TH) reaches 64°F for 60 seconds or the defrost time has exceeded 8 minutes. Defrost mode setting (n04) offers termination options for different Geographical conditions.

- Defrost in heavy snow area will extend defrost for 60 seconds, but reduce the heating time to execute more defrost operations.
- Defrost in light snow area will reduce defrost for 30 seconds.

2.2.2.3 AUTO charge mode and pump down function

Actuator	AUTO charge mode in cooling	Pump down in heating
Compressor (INV)	2ton: 56rps →26rps 3ton: 66rps →36rps 4ton: 56rps →26rps 5ton: 66rps →36rps	2ton: 66rps →26rps 3ton: 80rps →36rps 4ton: 58rps →26rps 5ton: 70rps →36rps
Outdoor fan (FAN)	Cooling fan control	Heating fan control
Reversing valve (ST1)	De-energized	Energized
Electronic expansion valve (EEV)	480pls	PI control to maintain discharge superheat

AUTO charge mode locks the compressor frequency in cooling. The LED will display the refrigerant coefficient if both the liquid line sub-cooling (SC) and compressor suction superheat (SH) of ESI system are proper. To keep the best Ecoer Smart Inverter (ESI) systems' performance and reliability, the following requirements should be followed in cooling.

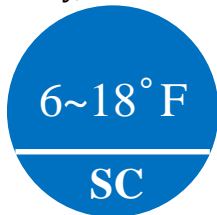

Target values in cooling mode



- If the LED displays "--" in AUTO charge mode for more than 20 minutes, stop charging and use a wrench to **clockwise** the TXV to ensure SH is no less than 7°F.
- In case that the cooling performance is terrible due to improper superheat (i.e. SH >20°F). Adjust the system according to
 - Activate AUTO charge mode to fix compressor frequency(RPS) by press BS4 for 5 seconds on outdoor PCB. Run the system for 15~20 minutes and check refrigerant coefficient number from LED display or ESS Pro App, **add refrigerant until you get 0.6.**
 - Adjust TXV opening to allow more refrigerant flow into indoor coil if SH is still larger than 20°F. Open the front panel of the indoor unit, then remove the TXV nut and use a wrench to **counterclockwise** the TXV until SH ≤ 20°F.

Pump down locks the compressor frequency in heating. Hold and press BS4 button for 5 seconds after set heating mode from thermostat, press BS2 button in one minute to enter pump down function. The low pressure will be displayed on the LED of main control board.

***NOTE** Low pressure protection is valid if LP <24.5psig.

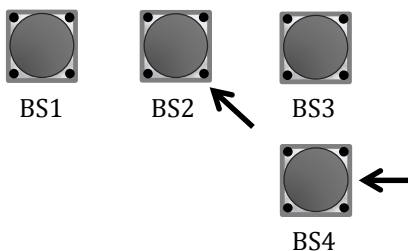

2.2.2.4 Compressor control

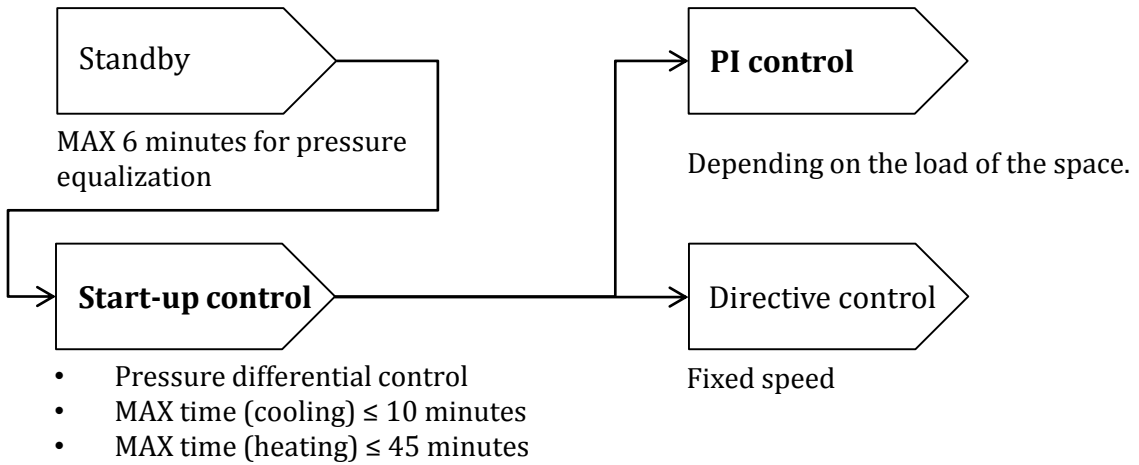

[Compressor RPS STEP]

STEP	RPS	STEP	RPS	STEP	RPS	STEP	RPS	STEP	RPS
1	-	9	28	17	44	25	60	33	76
2	-	10	30	18	46	26	62	34	78
3	16	11	32	19	48	27	64	35	80
4	18	12	34	20	50	28	66	36	82
5	20	13	36	21	52	29	68	37	84
6	22	14	38	22	54	30	70	38	86
7	24	15	40	23	56	31	72	39	88
8	26	16	42	24	58	32	74	40	90

Outdoor Model	2Ton	3Ton	4Ton	5Ton
Cooling Max RPS	70	80	66	76
Heating Max RPS	80	90	80	90

2.2.2.5 Fan control

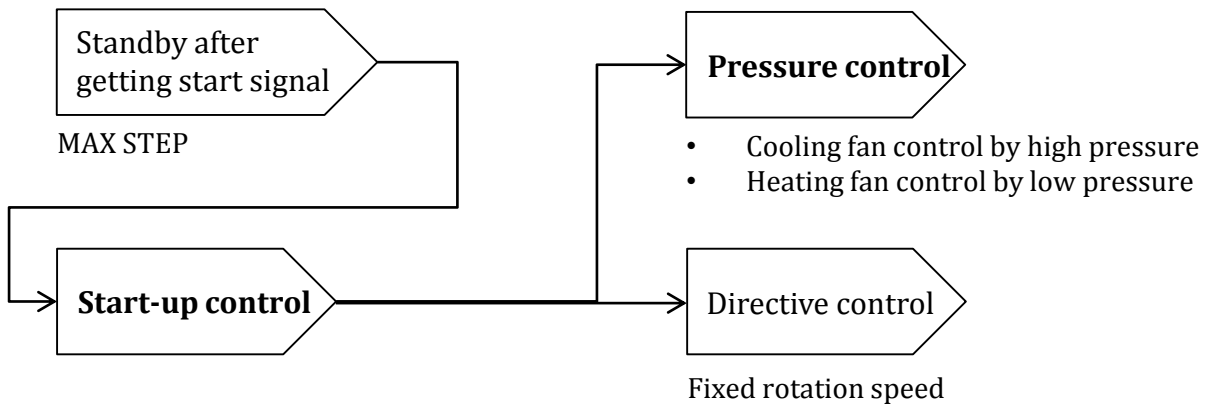

[FAN RPM STEP]

STEP	RPM	STEP	RPM	STEP	RPM	STEP	RPM	STEP	RPM
0	0	2	450	4	680	6	830	8	930
1	350	3	550	5	780	7	880	9	980

2.2.2.6 Electronic expansion valve(EEV) control

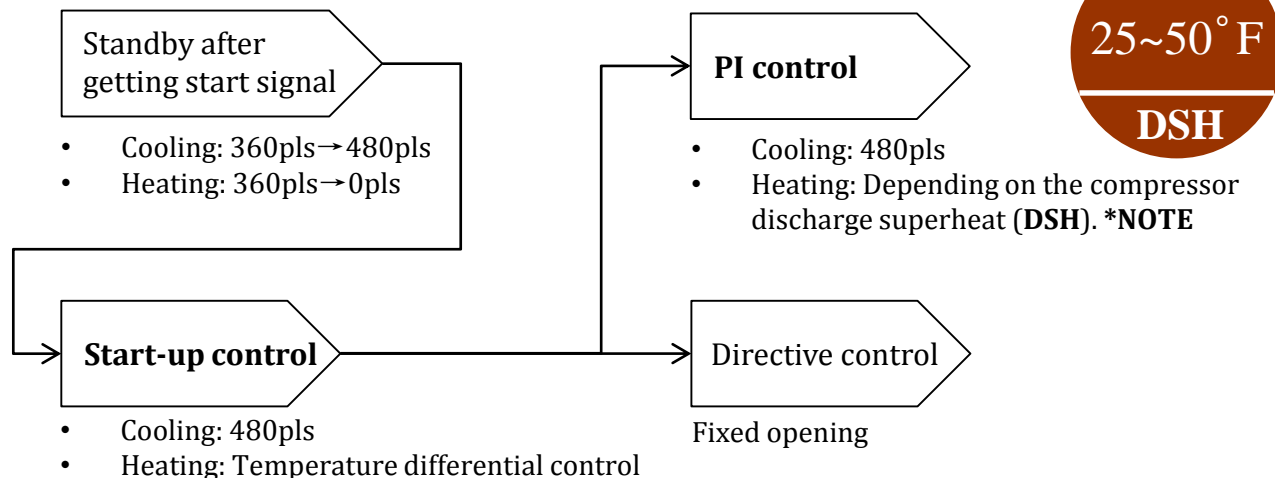

NOTE: Heating DSH should be between 25 ° F and 50 ° F with proper refrigerant charge.

- **Overcharged:** DSH is smaller than 18 ° F when the EEV opening < 72pls.
- **Undercharged:** DSH is bigger than 50 ° F when the EEV opening ≥ 460pls

2.2.2.7 Silent mode

In order to decrease the noises produced by condensing unit, the crucial noise resources should be limited. Once the silent mode has been activated by n05~n07 (refer to field setting), both the highest compressor frequency(RPS) and fan speed (RPM) are limited.

Max compressor frequency

Cooling Max Compressor RPS			
Condensing Unit	Standard Mode	Silent Mode (Level 1)	Super Silent Mode (Level 2)
2Ton	70	66	56
3Ton	80	76	70
4Ton	66	66	56
5Ton	76	68	58

Heating Max Compressor RPS			
Condensing Unit	Standard Mode	Silent Mode (Level 1)	Super Silent Mode (Level 2)
2Ton	80	70	60
3Ton	90	78	72
4Ton	80	62	52
5Ton	90	70	60

Max fan speed

Max Fan Speed (RPM)			
Condensing Unit	Standard Mode	Silent Mode (Level 1)	Super Silent Mode (Level 2)
2Ton	830	680	550
3Ton	930	Cooling:830 Heating:780	680
4Ton	880	830	780
5Ton	980	880	780

2.2.3. Protection controls

2.2.3.1 High pressure protection control

High pressure(HP) protection control is used to prevent extremely high pressures in the system and protect the compressor.

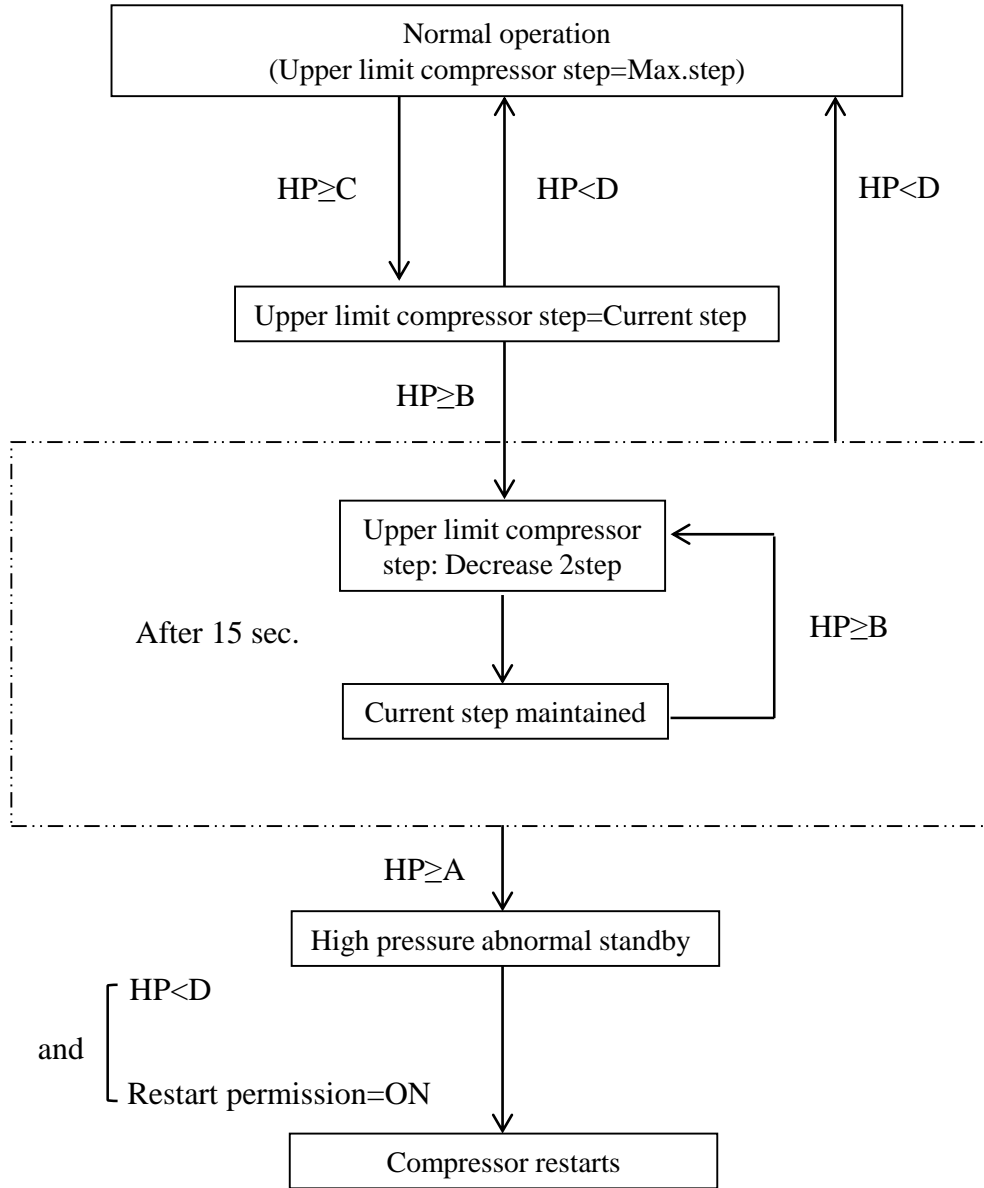

Symbol	EODA18H-2436/4860	
	Cooling	Heating
A	545psig [3.8MPa]	545psig [3.8MPa]
B	493psig [3.4MPa]	479psig [3.3MPa]
C	479psig [3.3MPa]	450psig [3.1MPa]
D	464psig [3.2MPa]	421psig [2.9MPa]

2.2.3.2 Low pressure protection control in cooling mode

Low pressure(LP) protection control in cooling is used to protect compressor against the transient decrease of low pressure.

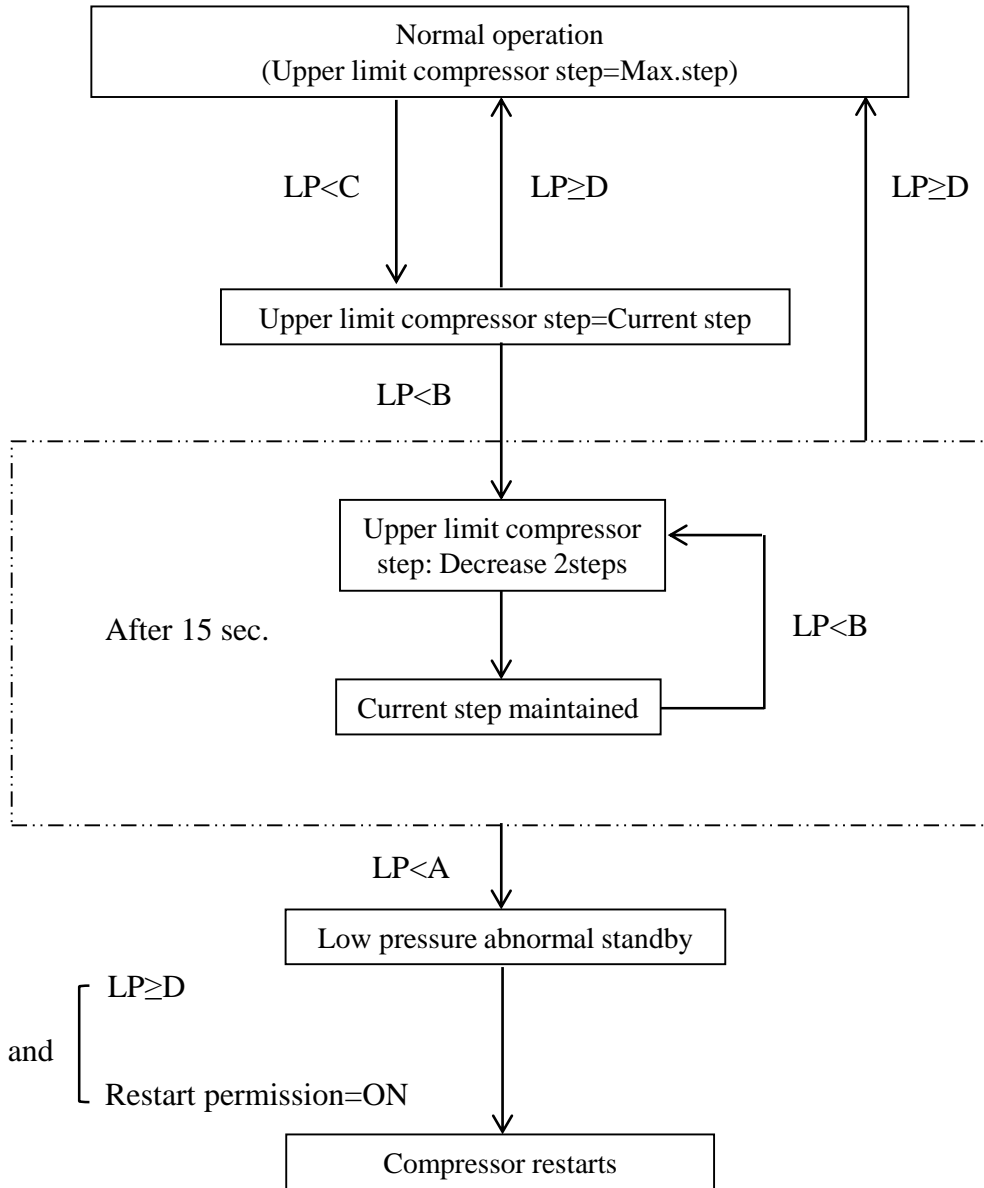

Symbol	EODA18H-2436/4860
A	24.5psig [0.17MPa]
B	43.5psig [0.30MPa]
C	61.0psig [0.42MPa]
D	72.5psig [0.50MPa]

2.2.3.3 Discharge temperature protection control

This discharge temperature(TD) protection control is used to protect the compressor internal temperature against a malfunction or transient increase of discharge pipe temperature.

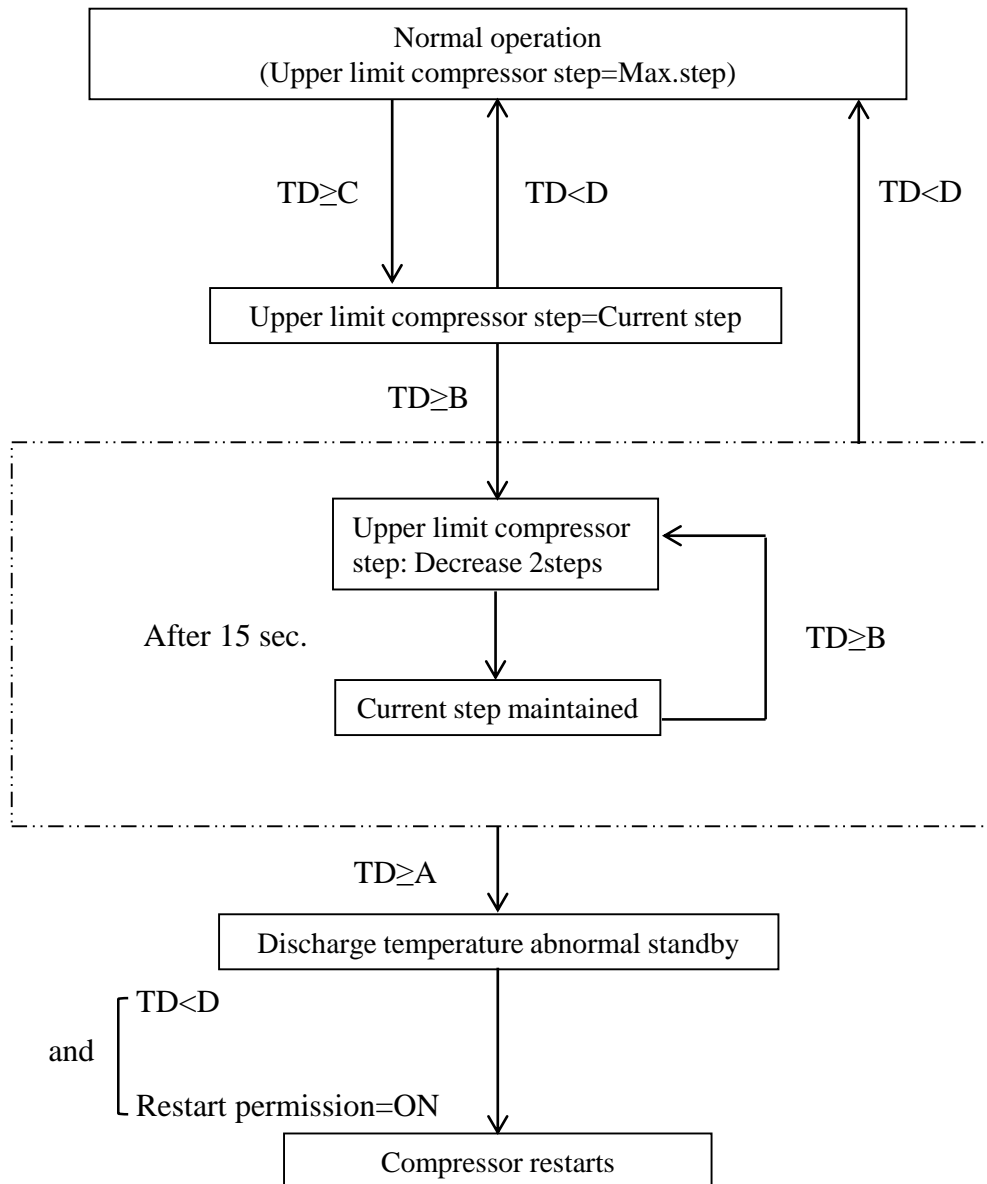

Symbol	EODA18H-2436/4860	
	Cooling	Heating
A	248°F (120°C)	230°F (110°C)
B	230°F (110°C)	212°F (100°C)
C	212°F (100°C)	194°F (90°C)
D	194°F (90°C)	176°F (80°C)

2.2.3.4 INV Module temperature protection control

Inverter module temperature (TF) protection control is performed to prevent tripping due to an abnormal increase in temperature.

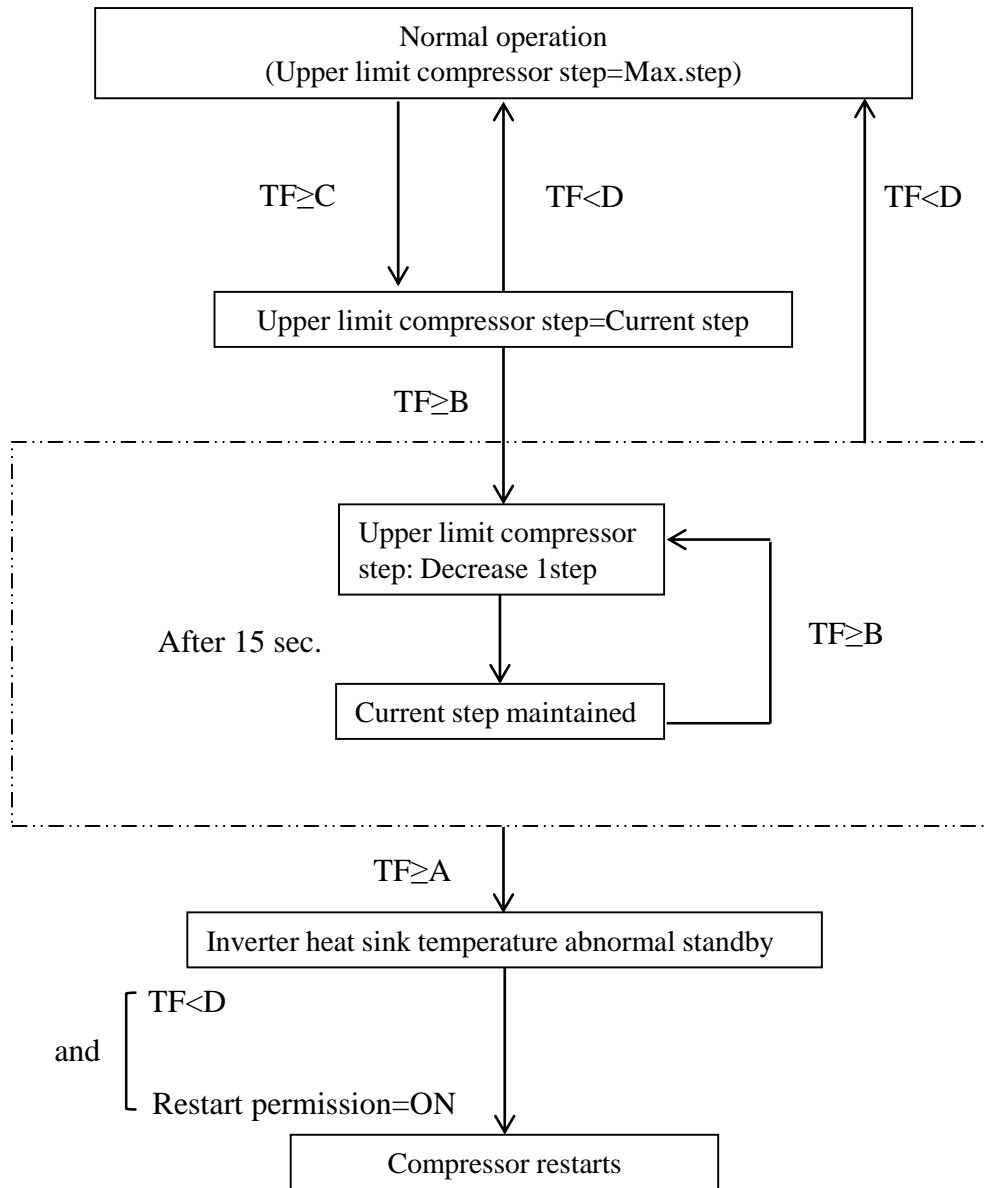

Symbol	EODA18H-2436		EODA18H-4860	
	Cooling	Heating	Cooling	Heating
A	181°F (83°C)	181°F (83°C)	176°F (80°C)	167°F (75°C)
B	174°F (79°C)	158°F (70°C)	158°F (70°C)	149°F (65°C)
C	167°F (75°C)	153°F (67°C)	151°F (66°C)	142°F (61°C)
D	162°F (72°C)	147°F (64°C)	145°F (63°C)	136°F (58°C)

2.2.3.5 Compressor over-current protection control

This control is performed to prevent tripping due to an abnormal transient compressor current (IA).

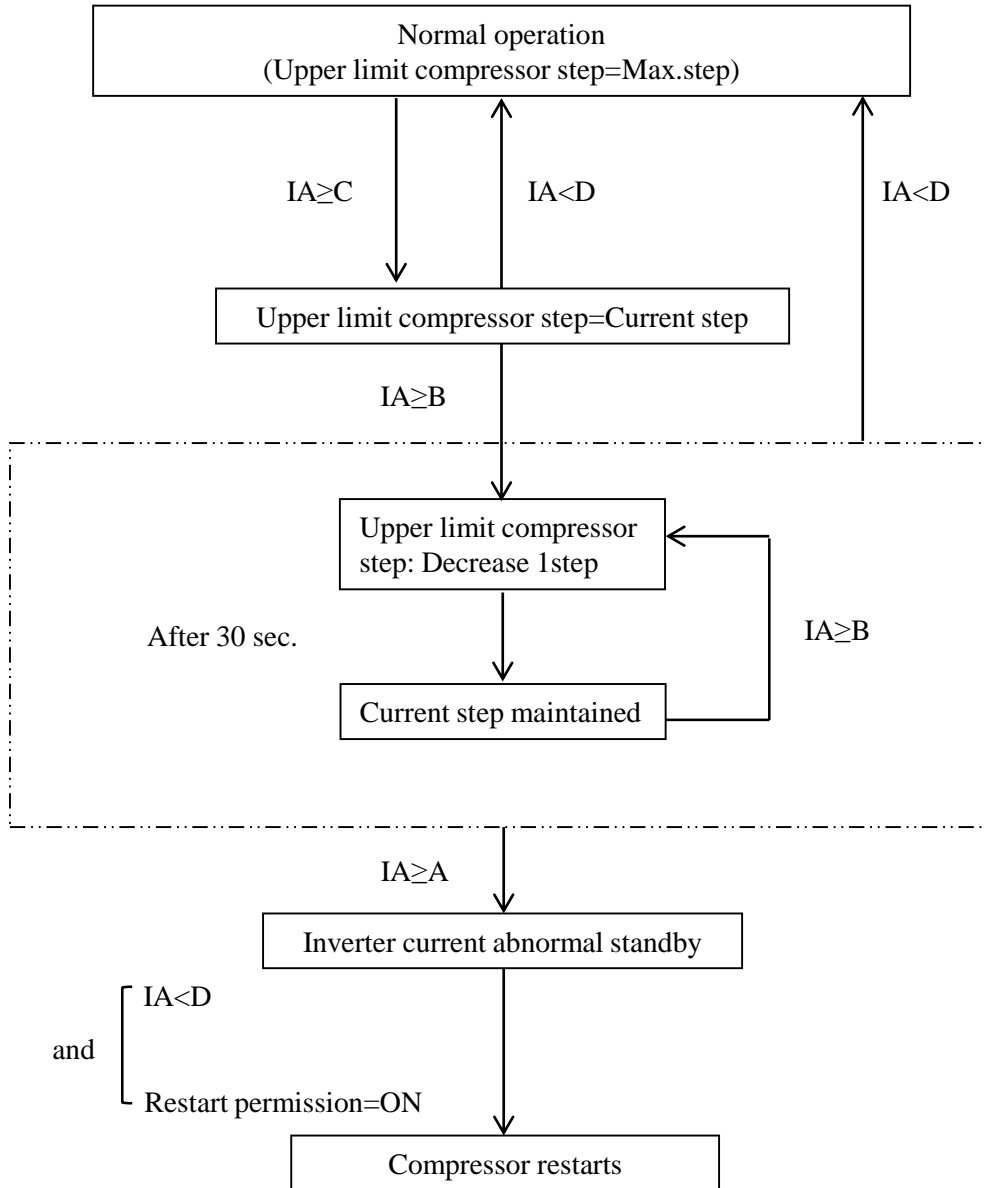

Symbol	EODA18H-2436		EODA18H-4860	
	Cooling	Heating	Cooling	Heating
A	16A	16A	20A	20A
B	9.2A	9.5A	12.1A	12.1A
C	8.6A	9.1A	11.7A	11.7A
D	8.0A	8.5A	11.2A	11.2A

2.3 Field Setting

2.3.1 Default display

LED on main control board can display the operating status of outdoor unit (ODU).

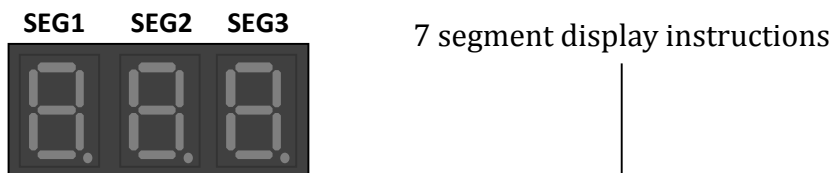

SEG1: Normally blank, but it displays codes “1~9” accordingly if there is damaged sensor and demand control requirement.

SEG1 Code	Description	Time
0	Software is updating through IoT gateway	About 5 min
1	High pressure sensor (HP) fault backup running	7 Days
2	Low pressure sensor (LP) fault backup running	7 Days
3	Compressor discharge temperature sensor (TD) fault backup running	7 Days
4	IPM module temperature sensor (TF) fault backup running	7 Days
5	Ambient temperature sensor (TA) fault backup running	120 Days
6	Defrost sensor (TH) fault backup running	90 Days
7	Compressor suction temperature sensor (TS) fault backup running	120 Days
8	Liquid line temperature sensor (TL) fault backup running	120 Days
9	Demand response	-

SEG2: Normally blank, but it will display code accordingly as below if outdoor unit is running under limited condition.

SEG2 Code	Description
0	Running under high pressure limit
1	Running under low pressure limit
2	Running under discharge temperature limit
3	Running under IPM module temperature limit
4	Running under compressor current limit

SEG3: It displays outdoor unit's operation mode.

SEG3 Code	Description
0	Stop without running signal (Y signal=OFF)
1	Ready to start after receiving running signal (Y signal=ON) *Note
2	Cooling mode
3	Heating mode
4	Oil return
5	Defrost
6	Manually defrost
7	AUTO charge assistant in cooling
8	Pump down in heating

Note: Compressor waits 3~6 minutes to restart.

Mode list (SEG3 Display)

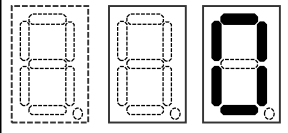
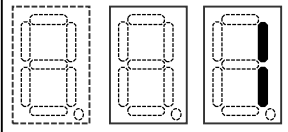
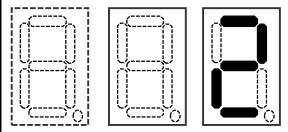
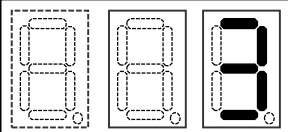
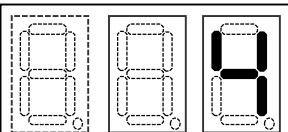
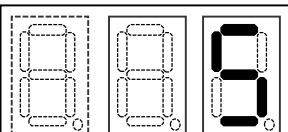
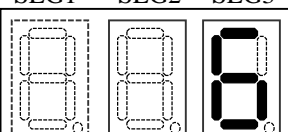
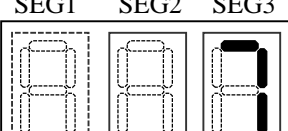
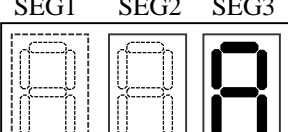
<p>Stop or standby without running signal (Y=OFF)</p>	<p>SEG1 SEG2 SEG3</p> 
<p>Wait to start after receiving running signal (Y=ON) (6 minutes for pressure equalization to restart)</p>	<p>SEG1 SEG2 SEG3</p> 
<p>Cooling running</p>	<p>SEG1 SEG2 SEG3</p> 
<p>Heating running</p>	<p>SEG1 SEG2 SEG3</p> 
<p>Oil return</p>	<p>SEG1 SEG2 SEG3</p> 
<p>Defrost</p>	<p>SEG1 SEG2 SEG3</p> 
<p>Manually forced defrost</p>	<p>SEG1 SEG2 SEG3</p> 
<p>AUTO charge assistant in cooling</p>	<p>SEG1 SEG2 SEG3</p> 
<p>Pump down in heating</p>	<p>SEG1 SEG2 SEG3</p> 

2.3.2 Setting by dip switches

Condensing units' functions can be applied by dipping switch and pressing buttons.

SW1 dip switch		Description	
NO.	Setting item	Status	Content
1	Reserved	-	-
2	Capacity selection *	ON	2 or 4 Ton
		OFF(factory)	3 or 5 Ton
3	AC only/Heat pump selection	ON	AC only
		OFF(factory)	Heat pump
4	Response for IoT command	ON	No
		OFF(factory)	Yes

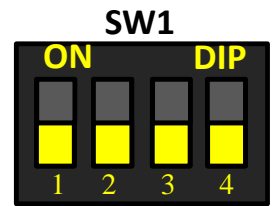

Use minor straight screwdriver to dip switch. **Power off the unit for at least two minute to activate this change.**

* Keep the default ODU's dip switch when 5 Ton matches with 2 or 3 Ton indoor unit for hyper heating.

2.3.3 Setting by pressing buttons

Query and setting operation can be done by pressing buttons on main control board.

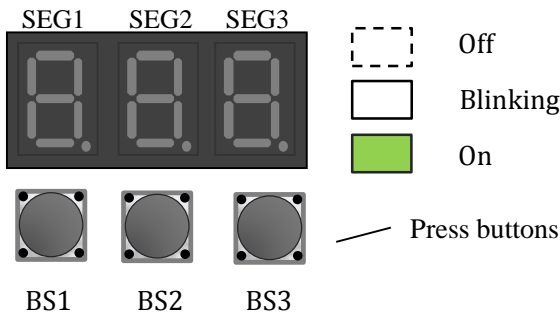

- BS1:** Menu or back button
- BS2:** UP button
- BS3:** Spot check and confirm button

Remarks:
Press or tip any directions are valid.

Press and hold BS1 for 5 seconds to set special functions.

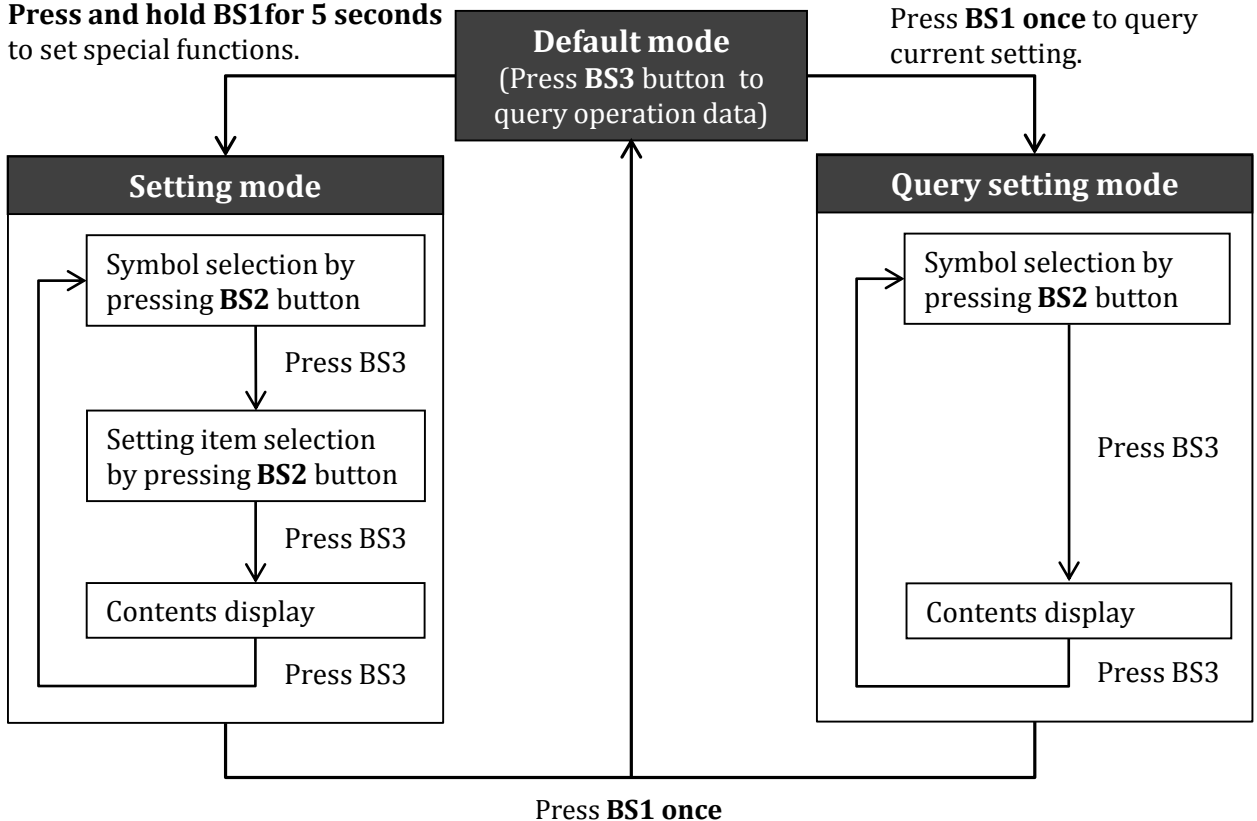

Default mode (Spot check)

System states can be showed on the 7 segments display (LED) of outdoor unit. Press **BS3** button to get code number and corresponding detailed information with an interval of one second.

Example: Code number

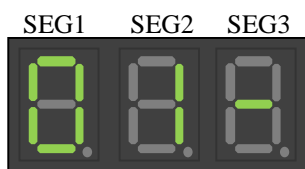

Detailed information

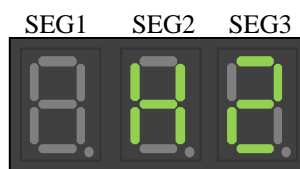

No.	Number content	Example	Description
Default	Refer to default display instructions	902	9: Demand 0: Running under high pressure limit 2: Cooling mode
01-	Outdoor unit type and capacity	H3	H: heat pump C: AC only 3: 3Ton
02-	Liquid line sub-cooling	10	10°F
03-	Compressor suction superheat	18	18°F
04-	Compressor speed	56	56RPS
05-	Electronic expansion valve opening	360	360pls
06-	Step of fan	8	The 8th step
07-	Low pressure (LP sensor)	145	145psig
08-	High pressure (HP sensor)	350	350psig
09-	Outdoor ambient temp. (TA)	95	95°F
10-	Compressor suction temp. (TS)	70	70°F
11-	Compressor discharge temp. (TD)	170	170°F
12-	Defrost sensor temp. (TH)	80	80°F
13-	Liquid line temp. (TL)	70	70°F
14-	Inverter module temp. (TF)	150	150°F
15-	Target evaporating temp. (Tes)	43	43°F
16-	Current evaporating temp. (Te)	45	45°F
17-	Target condensing temp. (Tcs)	104	104°F
18-	Current condensing temp. (Tc)	112	112°F
19-	Compressor DC current	10.1	10.1A
20-	Undercharged refrigerant signal	0	0: none 1: level 1 2: level 2 (severe)
21-	Main software version	A01	A01 version
22-	Inverter software version	b01	b01 version
23-	Current fault	E1	Display up to 5 *
24-	The last fault	F1	--: none
25-	Fault before the last fault	F2	--: none

Remark:

When multi-error codes exist at the same time, each code will be displayed one by one with an interval of one second.

Setting mode

Press and hold **BS1** button for 5 seconds to enter the parameter setting interface. The latest setting will be taken as the final one. Refer to page 22-23 for some settings example.

Symbol	Function	Item	Description
n00	Mode choice	0(factory)	Normal mode
		1	Dry mode *1
		2	High capacity mode *2
n01	Forced heating stop when ambient temperature is lower than specific value. Changing to heat by boiler or gas furnace in cold winter.	0	Stop heat pump when TA<-22°F
		1(factory)	Stop heat pump when TA<-3°F
		2	Stop heat pump when TA< 5 F 15°F *3
		3	Stop heat pump when TA< 10 F 30°F *3
n02	Outdoor unit outputs 24VAC from W terminal (CN5) at defrost operation or forced heating stop.	0(factory)	ON (24VAC output)
		1	OFF (No 24VAC output)
n03	Outdoor unit outputs 24VAC from W terminal (CN5) when ambient temperature is lower than specific value to start indoor auxiliary heater.	0(factory)	TA<15°F (24VAC output)
		1	TA< 10 F 30°F (24VAC output) *3
		2	TA< 5 F 40°F (24VAC output) *3
		3	TA<-3°F (24VAC output)
		4	OFF (No 24VAC output)
n04	Defrost mode setting *4	0	Defrost in heavy snow area
		1(factory)	Standard mode
		2	Defrost in light snow area
n05	Silent mode setting	0(factory)	None silent mode
		1	Silent mode (level 1)
		2	Super silent mode (level 2)
		3	Night silent mode (level 1)
		4	Night super silent mode (level 2)
n06	Night silent setting- start time	0	17:00
		1(factory)	18:00
		2	19:00
		3	20:00
		4	21:00
n07	Night silent setting- end time	0	5:00
		1(factory)	6:00
		2	7:00
		3	8:00
		4	9:00
n08	Forced defrost	0(factory)	OFF
		1	ON *5

Remarks:

1. The evaporating temperature of indoor coil can lower down to 28 ℉.
2. The evaporating temperature of indoor coil can lower down to 28 ℉ in cooling mode, and the condensing temperature can go up to 122 ℉ in heating mode.
3. Contact Ecoer Service Team to update software online if the units produced before April, 2019.
4. Reduce 10% heating time for heavy snow area, increase 10% heating time for light snow area.
5. System enters defrost after the heating start-up and an extra five minutes' control.

Example for mode choice (n00) setting

Step1
Press and hold BS1 for 5 seconds.

Step2
Press BS2 to select item (n00 for this case).

Step3
Press BS3 to enter sub-item setting.

n00=0, Normal mode./ n00=1, Dry mode./ n00=2, High capacity mode.

Step4
Press BS2 to change sub-item(n00 = 1).

Step5
Press BS3 twice to save and return for other settings.

Step6
Press BS1 to return.

Example for n02 & n03(Dual-heating) setting

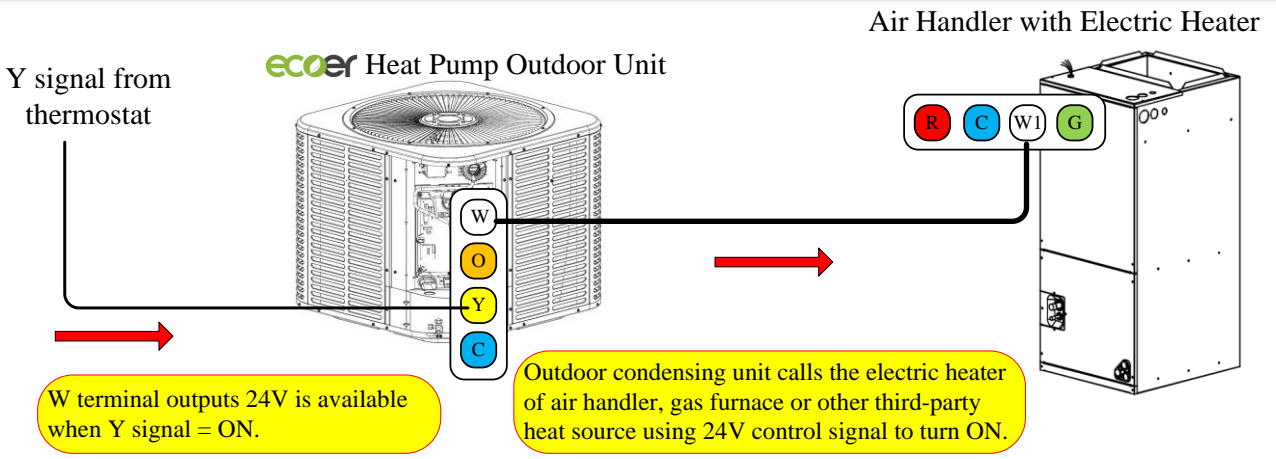

n02 Outdoor unit W terminal outputs 24VAC at defrost operation or forced heating stop(n01).
0 (factory): ON (24V output)
 1: OFF (No 24V output)

n03 Outdoor unit W terminal outputs 24VAC once ambient temperature is lower than specific value for auxiliary heating resource to start. **(Only available when n02 = 0 and Y signal = ON).**
 0(factory): TA<15 ℉ (24V output)
 1: TA<30 ℉ (24V output)
 2: TA<40 ℉ (24V output)
 3: TA<-3 ℉ (24V output)
 4: OFF (No 24V output)

Example:

Y signal = ON
 n02 = 0, n03 = 1

Outdoor unit W terminal outputs 24VAC when TA< 30 ℉.

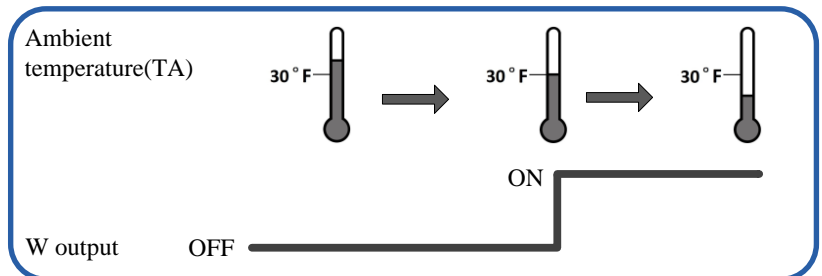

Illustration for n05~07 setting

Noise of silent mode is about 3 dB lower than normal mode.

Noise of super silent mode is about 6 dB lower than normal mode.

n05

Silent mode setting.

0 (Factory): none silent mode

1: Silent mode (level 1)

2: Super silent mode (level 2)

3: Night silent mode (level 1)

4: Super night silent mode (level 2)

n06

Night time setting
- Start time.

0: 17:00

1: 18:00 (Factory)

2: 19:00

3: 20:00

4: 21:00

n07

Night time setting
- End time.

0: 5:00

1: 6:00 (Factory)

2: 7:00

3: 8:00

4: 9:00

Example 1: n05 = 0 n06 = / n07 = /

⌚ 0:00

⌚ 24:00

Normal mode

Example 2: n05 = 1 n06 = / n07 = /

⌚ 0:00

⌚ 24:00

Silent mode (level 1)

Example 3: n05 = 2 n06 = / n07 = /

⌚ 0:00

⌚ 24:00

Super silent mode (level 2)

Example 4: n05 = 3 n06 = 0 n07 = 1

⌚ 0:00

⌚

⌚

⌚ 24:00

Normal mode

Silent mode (level 1)

Normal mode

Example 5: n05 = 4 n06 = 2 n07 = 3

⌚ 0:00

⌚

⌚

⌚ 24:00

Normal mode

Super silent mode (level 2)

Normal mode

Query Setting mode

Press **BS1** button once to query the current special setting, or check it from Ecoer Smart Service Pro App.

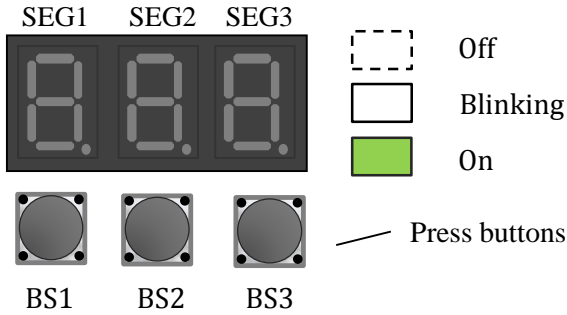

BS1: Menu or back button

BS2: UP button

BS3: Spot check and confirm button

Remarks:

Press or tip any directions are valid.

Step1

Press BS1 to enter query setting mode.



Step2

Press BS2 to select item (n05 for this case).



Step3

Press BS3 to check the current setting (n05 = 1).



Step4

Press BS3 to Step 2 interface for other setting check.



Press BS1 to return.

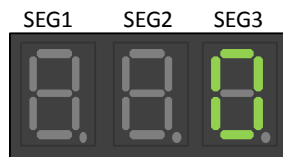

3. Trouble shooting

3.1 Problems without codes

If the system does not operate properly besides any malfunctions. Check the system based on the following procedures.

Symptoms	Possible causes	Solutions
The unit energized but the digital tube shows nothing	<ul style="list-style-type: none"> See the following page 	<ul style="list-style-type: none"> See the following page
System does not start-up but the digital tube shows normally	<ul style="list-style-type: none"> No 24 VAC signal from thermostat. Incompatible thermostat. 	<ul style="list-style-type: none"> Be sure Y/O/C wirings are connected correctly (See page 27~31) and the setting temperature is proper. Use another 24 volts common thermostat.
System operates mode reversely	<ul style="list-style-type: none"> Incorrect O/B signal selection. 	<ul style="list-style-type: none"> Choose O for cooling from thermostat.
System cannot cool well	<ul style="list-style-type: none"> Outside temperature is too high. Outside temperature is too low. Dirty air filter or blocked outlet of indoor unit. Too little refrigerant in the system. Too big comp. suction superheat. 	<ul style="list-style-type: none"> Normal protection control to limit RPS Ensure the cooling loads Replace the air filter and eliminate any obstacles. Check refrigerant amount or any leaks. Counterclockwise the TXV (Make sure the refrigerant coefficient is 0.6)
System cannot heat well	<ul style="list-style-type: none"> Outside temperature is too low but no third-party heater inside. The outdoor coil is dirty or has been covered by heavy snow. Dirty air filter. Micro channel coil has been used in heating Lack of refrigerant. 	<ul style="list-style-type: none"> Install auxiliary heater for backup *Dual-heating is recommended. Clean the outdoor coil. Replace the air filter. No micro channel coils shall be used for heat pump. Check refrigerant amount or any leaks.

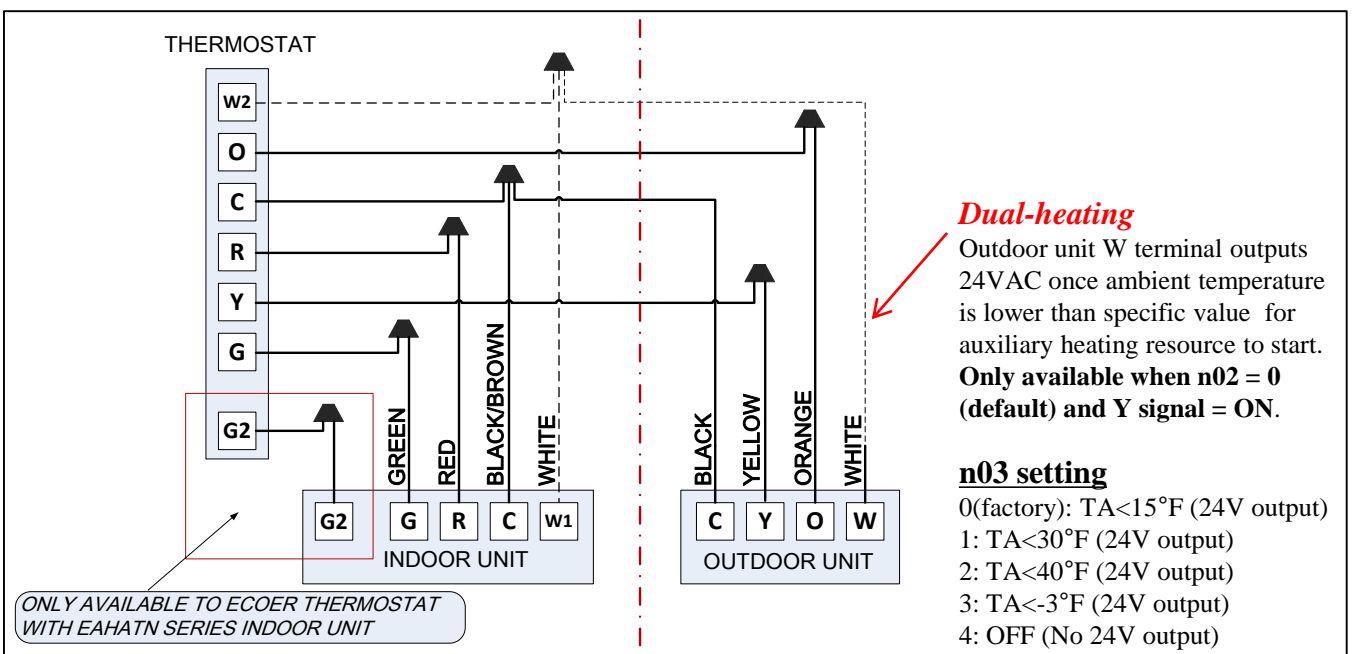

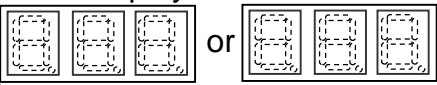
No Display

The unit energized but the digital tube shows nothing

1.Error definition:

No display on main control board even though the unit has been powered ON.

2.Possible causes:

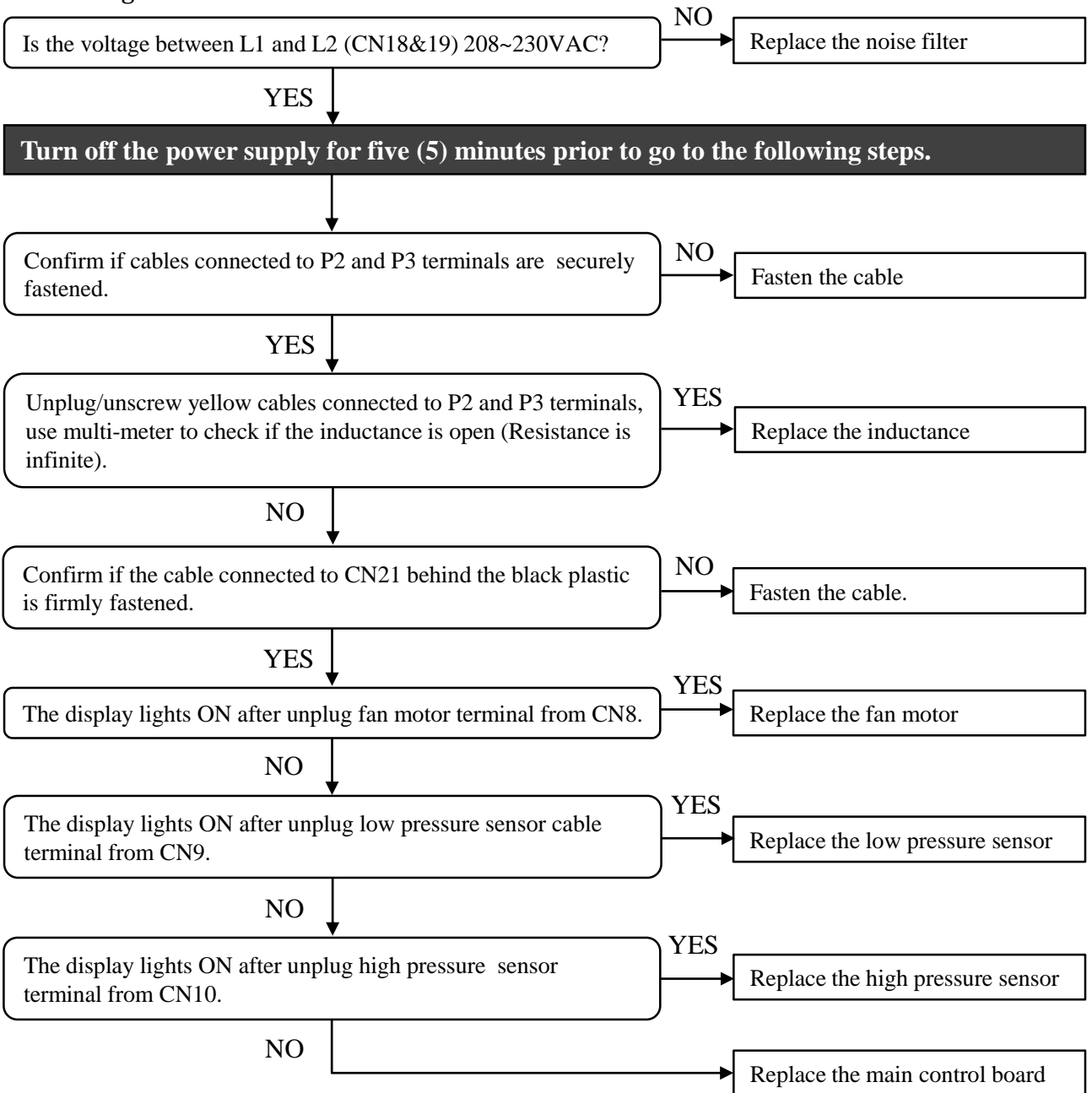
- Damaged noise filter
- Damaged inductance
- Loose connection at port on main control board
- Damaged pressure sensor
- Damaged fan motor
- Damaged main control board



Ecoer Variable Speed Heat Pump Matches with Air Handler and Electric Heater

- R 24 Volt +
 - C Common
 - G Fan Operation
 - Y Air Conditioning (Heating or Cooling)
 - O Mode Switch (Energize in Cooling)
-
- W2 Aux / Emergency Heat (Thermostat)
 - W1 Heat with Fan Linkage (Air Handler)
 - W Output to Thermostat (Outdoor Unit)

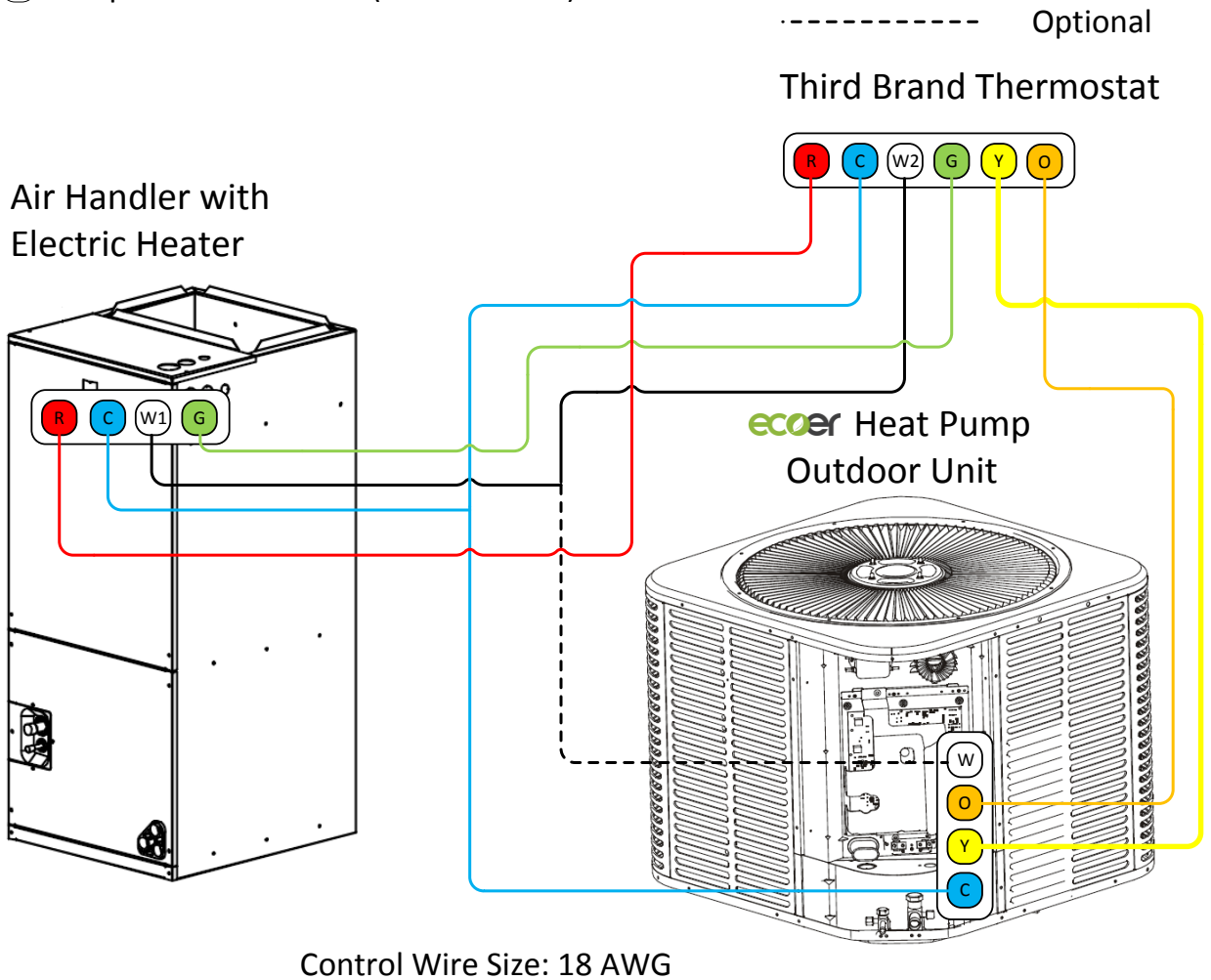

Refer to installation guides of actual thermostat or equipment to verify the control wiring.

Ecoer Variable Speed Air Conditioner (Cooling Only) Matches with Air Handler

- R 24 Volt +
 - C Common
 - G Fan Operation
 - Y Air Conditioning (Heating or Cooling)
 - O Mode Switch (Energize in Cooling)
-
- W2 Aux / Emergency Heat (Thermostat)
 - W1 Heat with Fan Linkage (Air Handler)
 - W Output to Thermostat (Outdoor Unit)

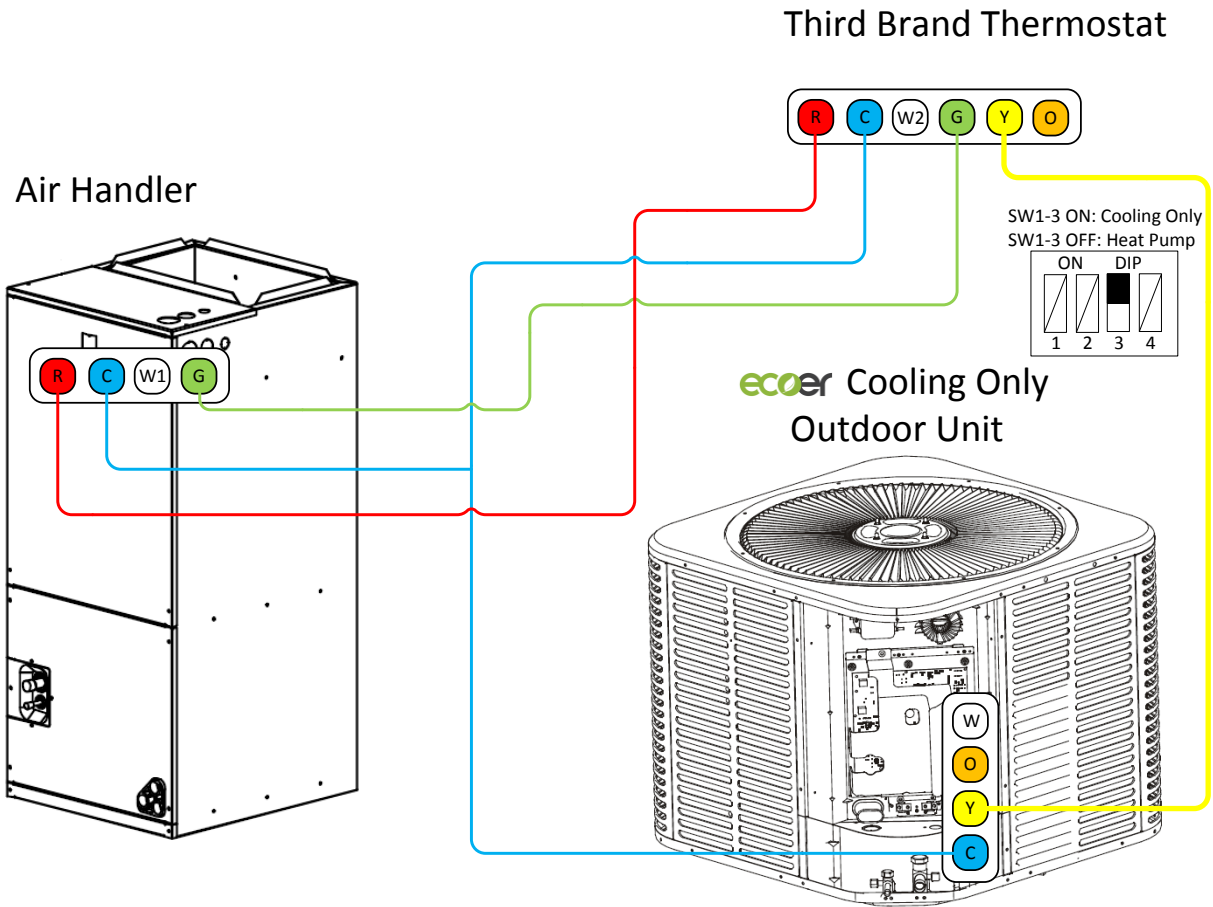

Control Wire Size: 18 AWG

Refer to installation guides of actual thermostat or equipment to verify the control wiring.

Ecoer Variable Speed Heat Pump Matches with Air Handler (Ecoer Thermostat)

- R 24 Volt +
- C Common
- G Fan Operation
- G2 Fan Operation (Dehumidification Mode)
- Y Air Conditioning (Heating or Cooling)
- O Mode Switch (Energize in Cooling)

- W2 Aux / Emergency Heat (Thermostat)
- W1 Heat with Fan Linkage (Air Handler)
- W Output to Thermostat (Outdoor Unit)

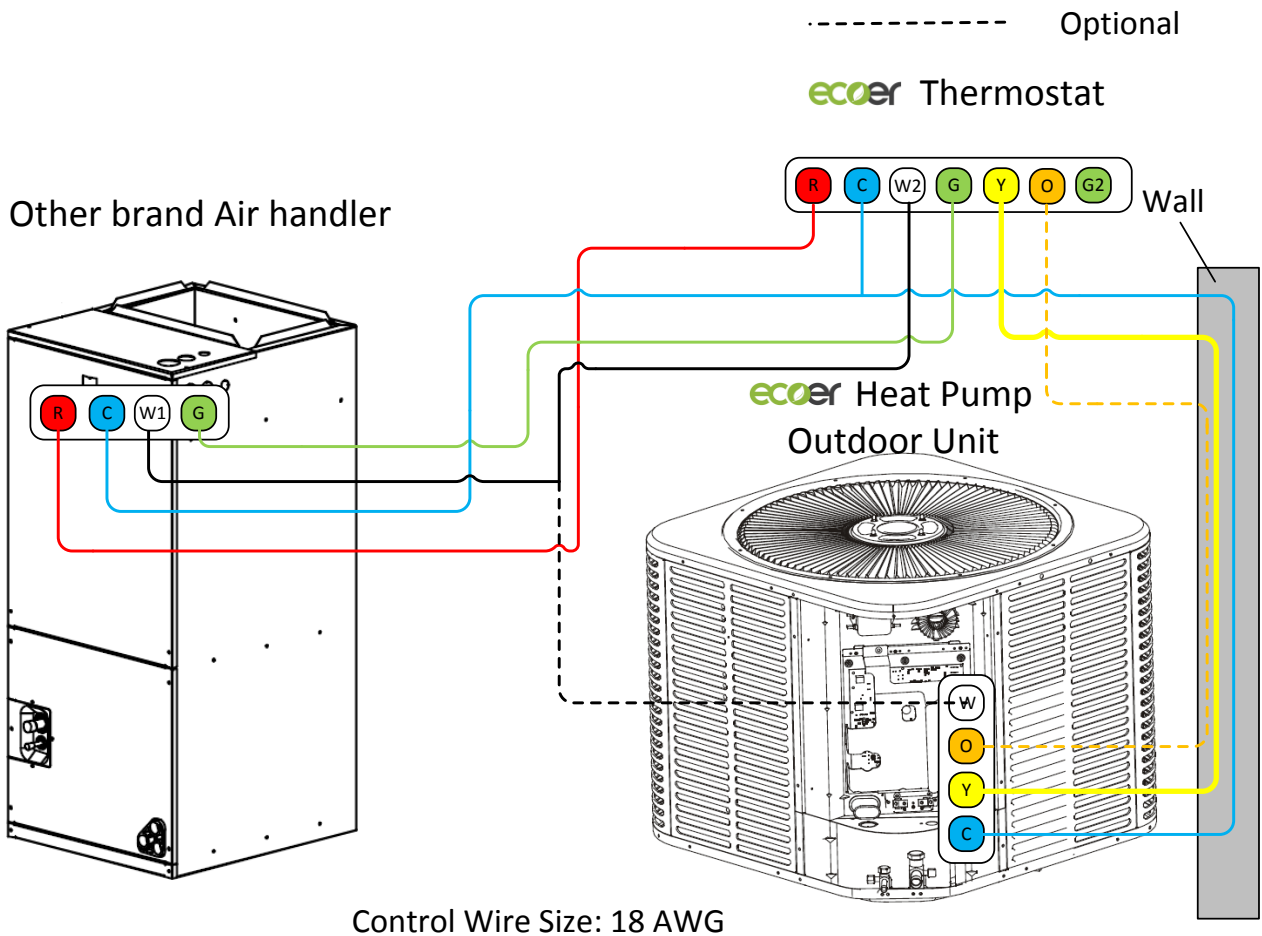

Control Wire Size: 18 AWG

Ecoer provides a unique solution to achieve heat pump function without O signal.

Refer to installation guides of actual thermostat or equipment to verify the control wiring.

Ecoer Variable Speed Heat Pump Matches with EAHATN Air Handler and Electric Heater (Ecoer Thermostat)

- R 24 Volt +
- C Common
- G Fan Operation
- G2 Fan Operation (Dehumidification Mode)
- Y Air Conditioning (Heating or Cooling)
- O Mode Switch (Energize in Cooling)

- W2 Aux / Emergency Heat (Thermostat)
- W1 Heat with Fan Linkage (Air Handler)
- W Output to Thermostat (Outdoor Unit)

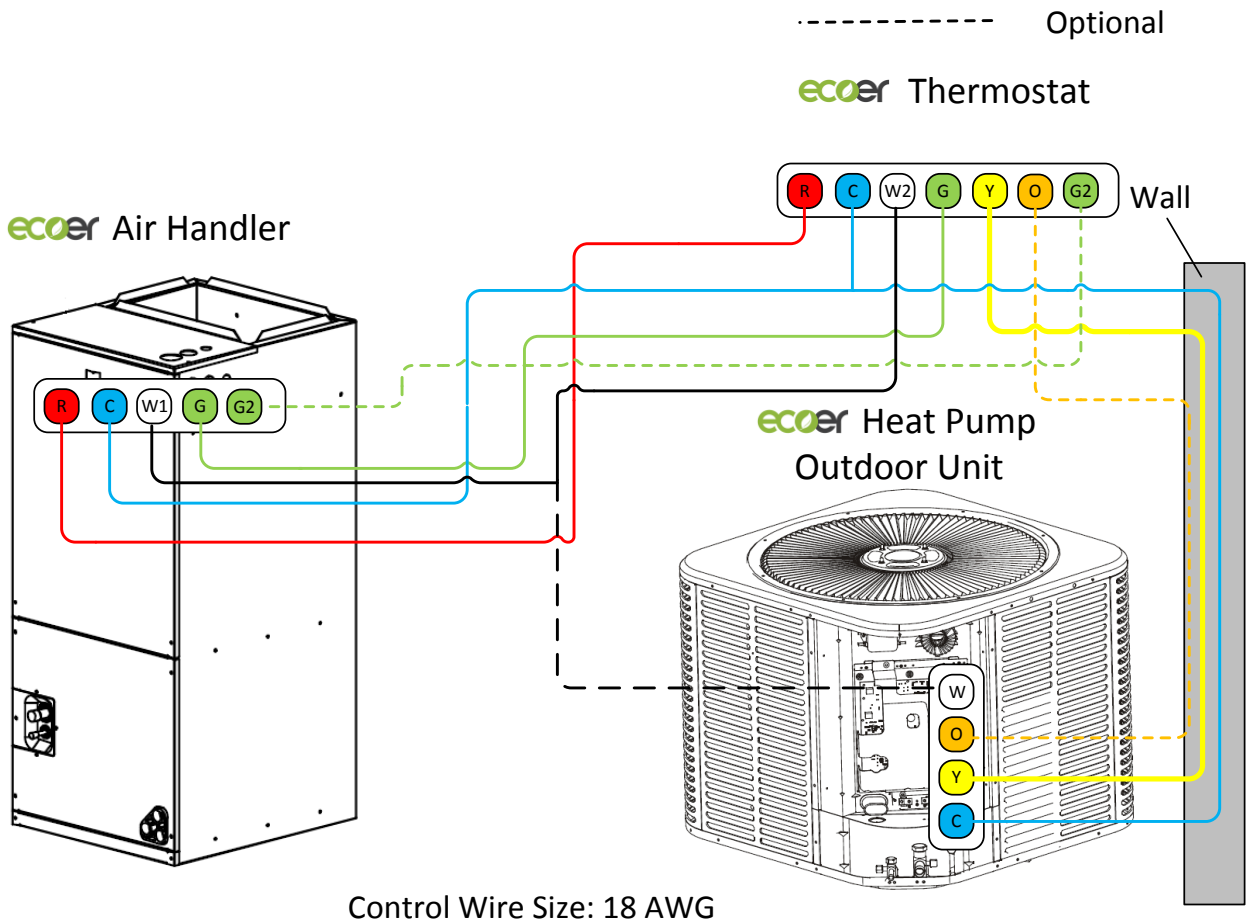

Ecoer provides a unique solution to achieve heat pump function without O signal.

Refer to installation guides of actual thermostat or equipment to verify the control wiring.

Ecoer Variable Speed Heat Pump Matches with Cased Coil and Furnace (Ecoer Thermostat)

- R** 24 Volt +
- C** Common
- G** Fan Operation
- G2** Fan Operation (Dehumidification Mode)
- Y** Air Conditioning (Heating or Cooling)
- O** Mode Switch (Energize in Cooling)
- W2** Aux / Emergency Heat (Thermostat)
- W1** Heat with Fan Linkage (Air Handler)
- W** Output to Thermostat (Outdoor Unit)

Cased Coil with Furnace

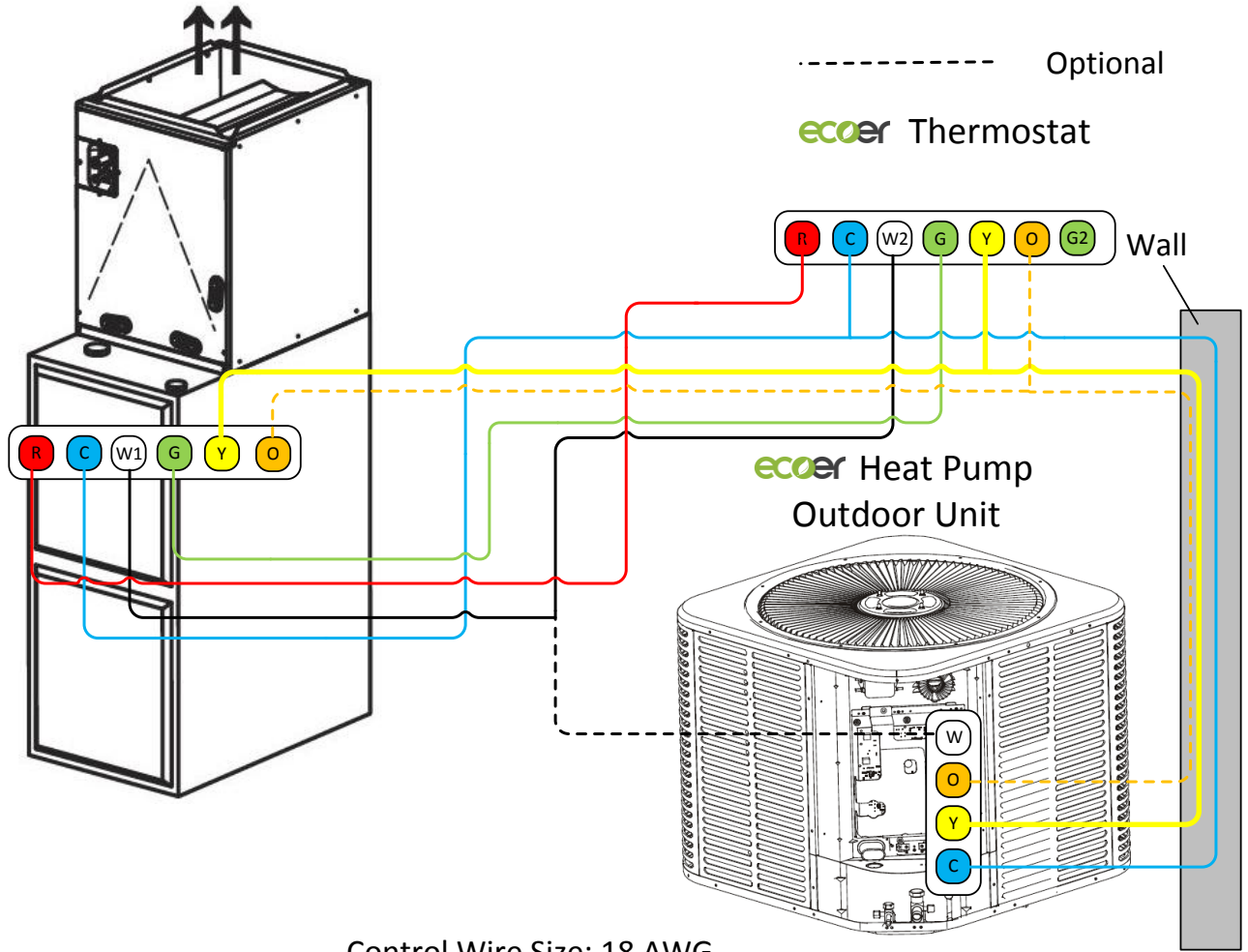

Control Wire Size: 18 AWG

Ecoer provides a unique solution to achieve heat pump function without O signal.

Refer to installation guides of actual thermostat or equipment to verify the control wiring.

3.2 Error codes List

Past error codes can be spot checked by BS3 button, and seen from Ecoer Smart Service Pro App.

Error Code	Description	Legend	Page
P1	High pressure protection		33
E1	System locks up when P1 has occurred six times in 3 hours.	Cannot restart *1	
P2	Low pressure protection in cooling mode		34
E2	System locks up when P2 has occurred six times within 3 hours.	Cannot restart *1	
P3	Compressor discharge temperature (TD) protection		35
E3	System locks up when P3 has occurred six times within 3 hours.	Cannot restart *1	
P4	Compressor discharge temp. (TD) sensor is disconnected or damaged		36
P5	Inverter module temperature (TF) protection		37
E5	System locks up when P5 has occurred six times within 3 hours.	Cannot restart *1	
P6	Compressor over-current protection		38
E6	System locks up when P6 has occurred six times within 3 hours.	Cannot restart *1	
P7	Liquid slugging protection		39-40
E7	System locks up when P7 has occurred three times within 5 hours.	Cannot restart *1	
P8	Low compressor voltage protection		41
E8	System locks up when P8 has occurred three times within 60 minutes.	Cannot restart *1	
P9	Incorrect compressor line sequence	Cannot restart *1	41
PA	DC fan motor over-load protection	Cannot restart *1	42
F1	Ambient temperature (TA) sensor fault	Backup running*2	43
F2	Compressor suction temperature (TS) sensor fault	Backup running*2	44
F3	Liquid line temperature (TL) sensor fault	Backup running*2	45
F4	Defrost temperature (TH) sensor fault	Backup running*2	46
F5	Compressor discharge temperature (TD) sensor fault	Backup running*2	47
F6	Inverter module temperature (TF) sensor fault	Backup running*2	48
F7	High pressure (HP) sensor fault	Backup running*2	49
F8	Low pressure (LP) sensor fault	Backup running*2	50
E4	Communication fault between main chip and INV drive chip	Cannot restart *1	51
H1	Ambient temperature limit operation in cooling mode		52
H2	Ambient temperature limit operation in heating mode		
H3	Abnormal switch alarm for 4-way valve	Just show alarm	53
H4	Defrost temperature (TH) sensor is disconnected or damaged		54
H5	EEPROM fault		55
H6	Low voltage alarm		55
HF	Abnormal function control	Alarm	55
C0-CC	Compressor INV module protection		56-57
E0	System locks up when C0~CA has occurred 3 times within 60 minutes.	Cannot restart *1	

Remarks:

1. Disconnect power supply switch for 5 minutes to reset, then turn on power supply for the system.
2. System goes to backup running under sensors fault varies from 7 to 120 days. Allow up to two sensors backup running at the same time.

Display



High pressure protection

1.Error definition:

P1: The detected high pressure is no less than 566psig.

E1: System locks up when P1 has occurred six times within 3 hours.

2.Possible causes:

- Service valves are closed
- The system has been severely over-charged
- Dirty/Clogged heat exchanger of outdoor unit in cooling mode
- Dirty indoor air filter or micro channel coil has been used for heat pump
- The refrigerant blocked in high pressure zone because of damaged TXV/EEV
- Damaged indoor fan motor or G signal lost resulting in indoor unit FAN stops in heating
- Damaged high pressure sensor
- Damaged main control board

Check visible parts for the system
 1) Closed service valve; 2) Dirty heat exchanger or **micro channel coil has been used in heating operation;**
 3) Dirty air filter; 4) FAN is not operating *NOTE1

Satisfy any contents above. YES → Correct specific point

NO ↓
 Can the pressure transduce properly based on **High Pressure Sensor Voltage Characteristics D.** *NOTE2
 NO → Replace the high pressure sensor

YES ↓
 Is the high pressure close to 566psig before protection?
 NO → Replace the main control board

YES ↓
 Whether the low pressure has been evacuated? *NOTE3
 YES → **Cooling mode:** Check if the indoor TXV is dirty plugging.
Heating mode: Check if the outdoor EEV is dirty plugging.

NO ↓
 Use AUTO charge mode to check whether there is too much refrigerant in the system.
 Replace the main control board if the protection happens again with proper refrigerant amount.

NOTES:

1. It's normal control if heating oil return operation is enforced to execute even though the Y signal=OFF (Indoor fan stops because there is No G signal). **Or connect R and G together to judge if the fan works. Yes-> Replace the indoor PCB; No-> Replace the indoor motor.**
2. Connect a pressure gauge to liquid service valve in cooling mode, gas service valve in heating mode. Compare the value difference between gauged pressure and the transduced one by high pressure sensor (spot check by BS3 button or check the data from ESS Pro App).
3. Abnormal TXV/EEV will lead to the refrigerant blockage in the high pressure side.

Low pressure protection in cooling mode

Display

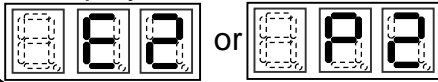

1. Error definition:

P2: The detected low pressure in cooling mode is less than 24.5psig.

E2: System locks up when P2 has occurred six times within 3 hours.

2. Possible causes:

- Service valves are closed
- Dirty air filter or indoor heat exchanger
- Outside temperature is lower than 40°F
- Too little refrigerant in the system
- Damaged indoor R410A TXV
- G(G2) signal is lost resulting in indoor unit FAN=OFF
- Damaged low pressure sensor
- Damaged main control board

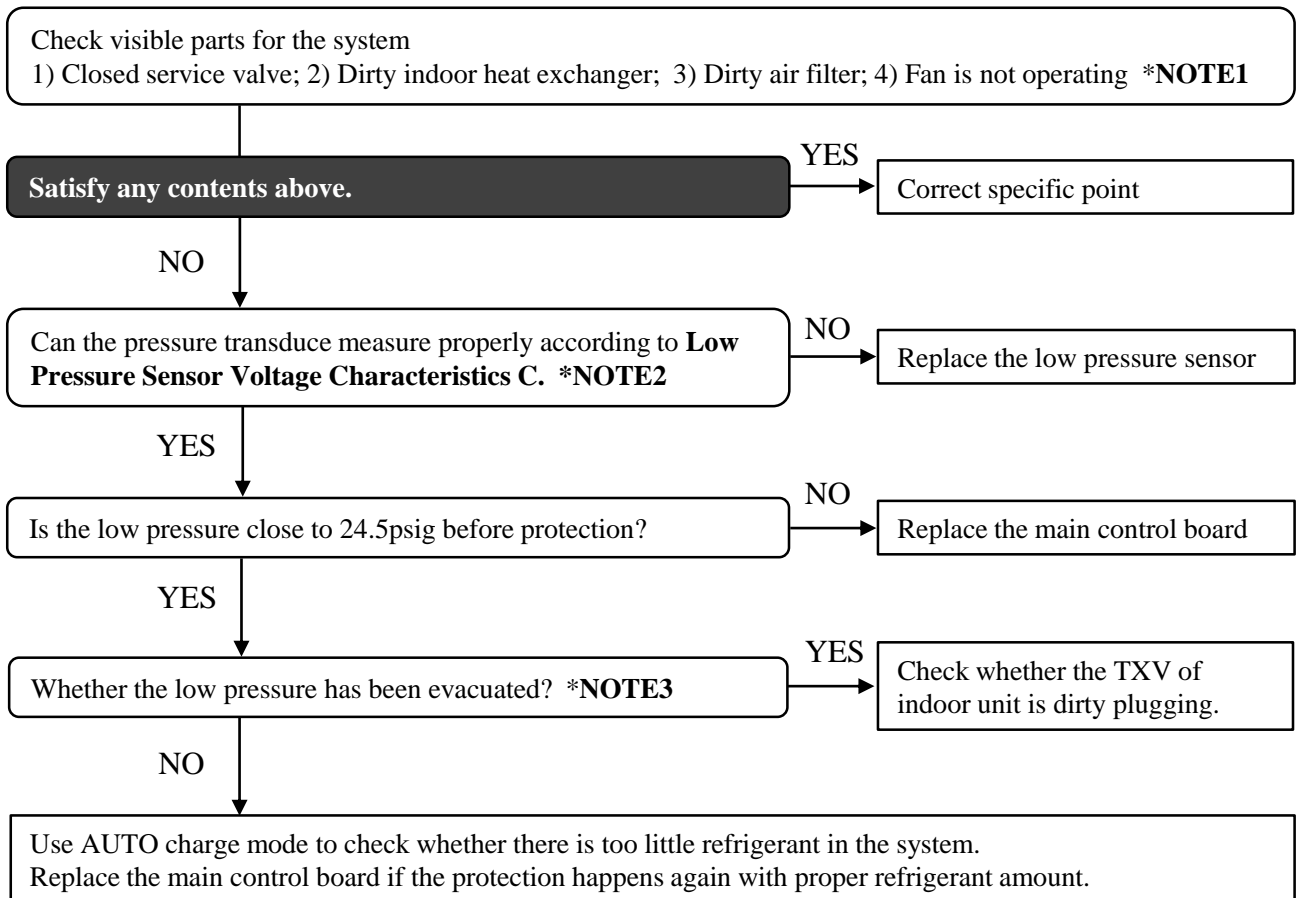

NOTES:

1. It's normal control if cooling oil return operation is enforced to execute even though the Y signal=OFF (Indoor fan stops because there is No G/G2 signal). **Or connect R and G(G2) together to judge if the fan works. Yes-> Replace the indoor PCB; No-> Replace the indoor motor.**
2. Connect a pressure gauge to gauge port, compare the difference between the gauged pressure and the transduced one by low pressure sensor (spot check by BS3 button or check the data from ESS Pro App).
3. Abnormal TXV will lead to the refrigerant blockage in the high pressure side.

Display  **Compressor discharge temperature(TD) protection**

1.Error definition:

P3: The detected discharge temperature(TD) is no less than specific value.

Cooling: 248°F Heating: 230°F

E3: System locks up when P3 has occurred six times within 3 hours.

2.Possible causes:

- Too little refrigerant remains in the system
- Dirty plugging of EEV or indoor TXV
- Damaged discharge temperature sensor
- Damaged main control board

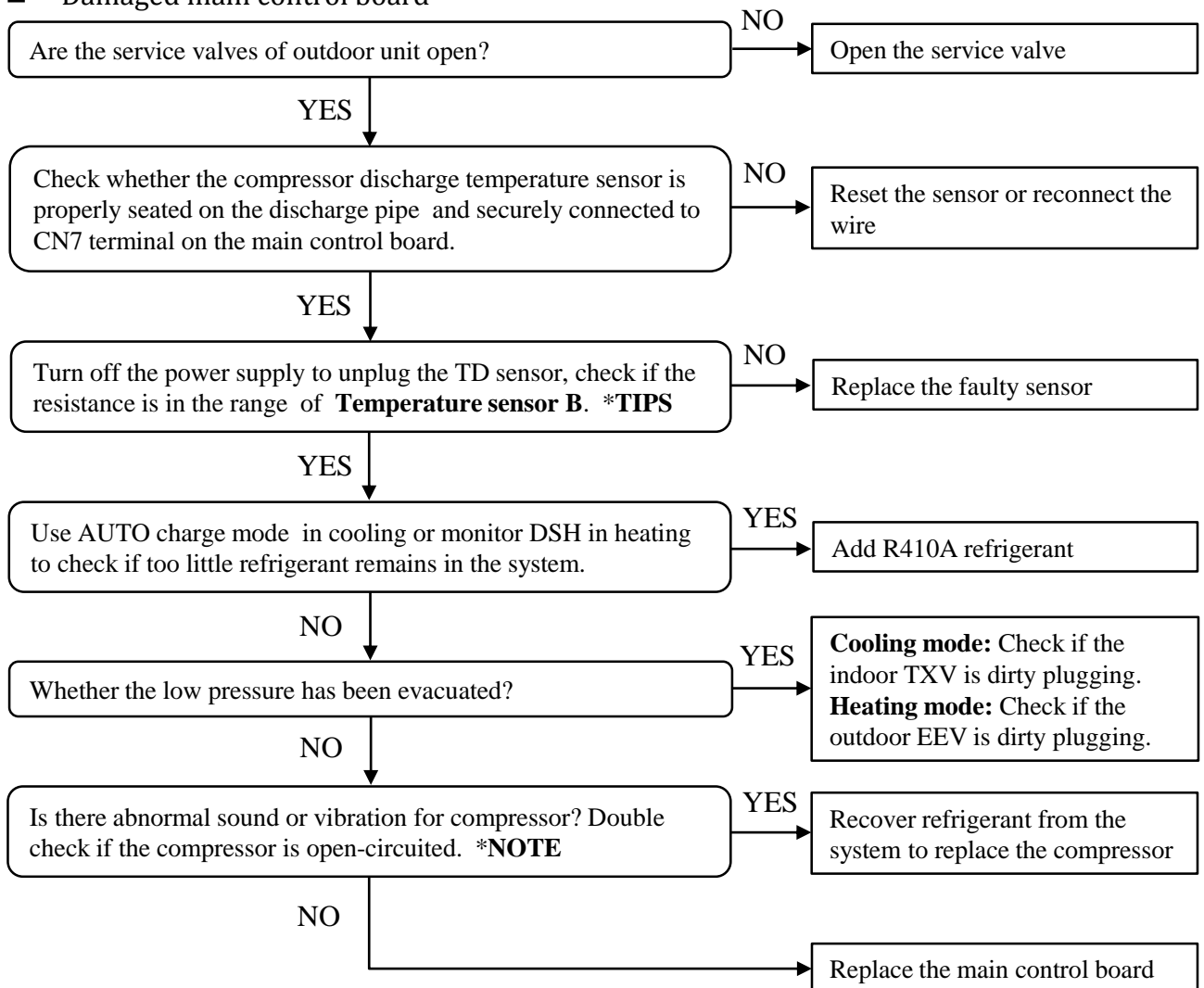
**TIPS:**

Technically measure the DC voltage of the temperature sensor also works when outdoor unit powers on.

NOTE: Normal resistance for compressor

3-phase resistance (UV, UW, VW) for compressor is less than 5Ω.

The insulation resistance (any phase to Ground) for compressor is greater than 100KΩ.

Display

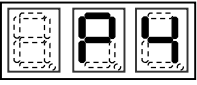

Compressor discharge temperature(TD) sensor is disconnected or damaged

1.Error definition:

Compressor discharge temperature (TD) sensor is disconnected or damaged.
 $TD < T_c - 9^{\circ}\text{F}$ for 20 minutes, T_c means the condensing temperature.

2.Possible causes:

- Discharge temperature (TD) sensor is disconnected or damaged
- Loose connection to CN7 terminal on main control board
- Damaged main control board
- There are other heat sources around the sensor

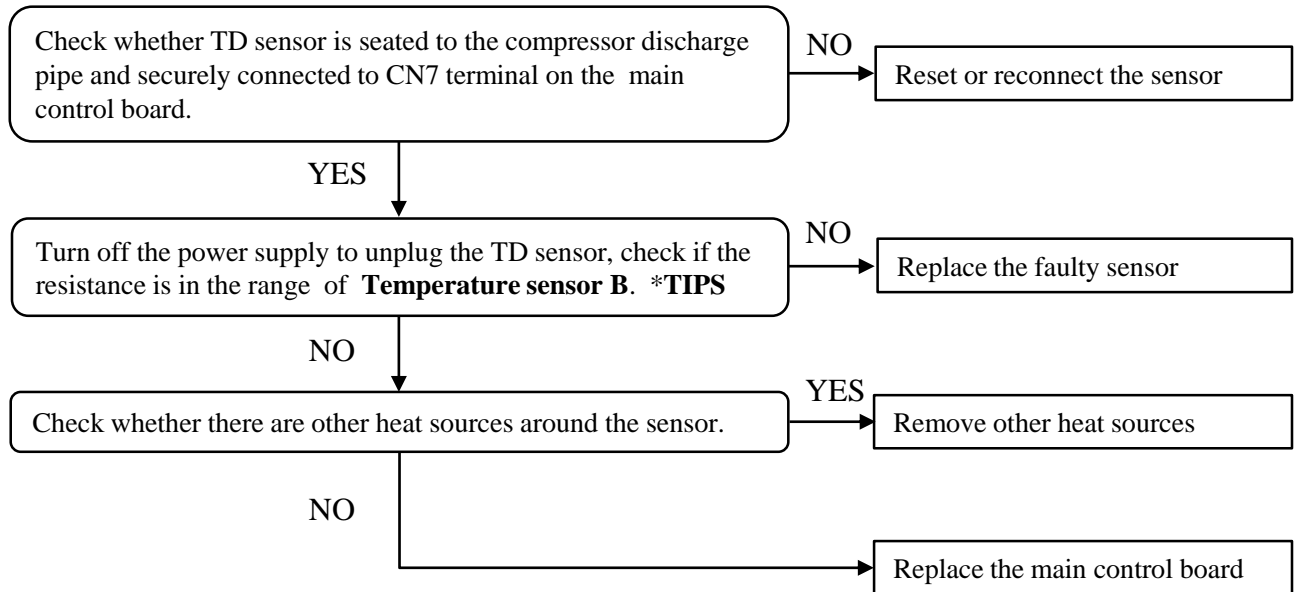

TIPS:

Technically measure the DC voltage of the temperature sensor also works when outdoor unit powers on.

Display  **Inverter module temperature(TF) protection**

1.Error definition:

P5: The detected value of module temperature (TF) is no less than specific value.

EODA18H-2436: 181°F

EODA18H-4860: 176°F in cooling mode/ 167°F in heating mode

E5: System locks up when P5 has occurred six times within 3 hours.

2.Possible causes:

- Clogged fin of radiator resulting in poor heat transfer
- Dirty and blocked outdoor heat exchanger
- Damaged TF sensor
- Misjudgment caused by resistance drift of TF sensor
- Damaged main control board

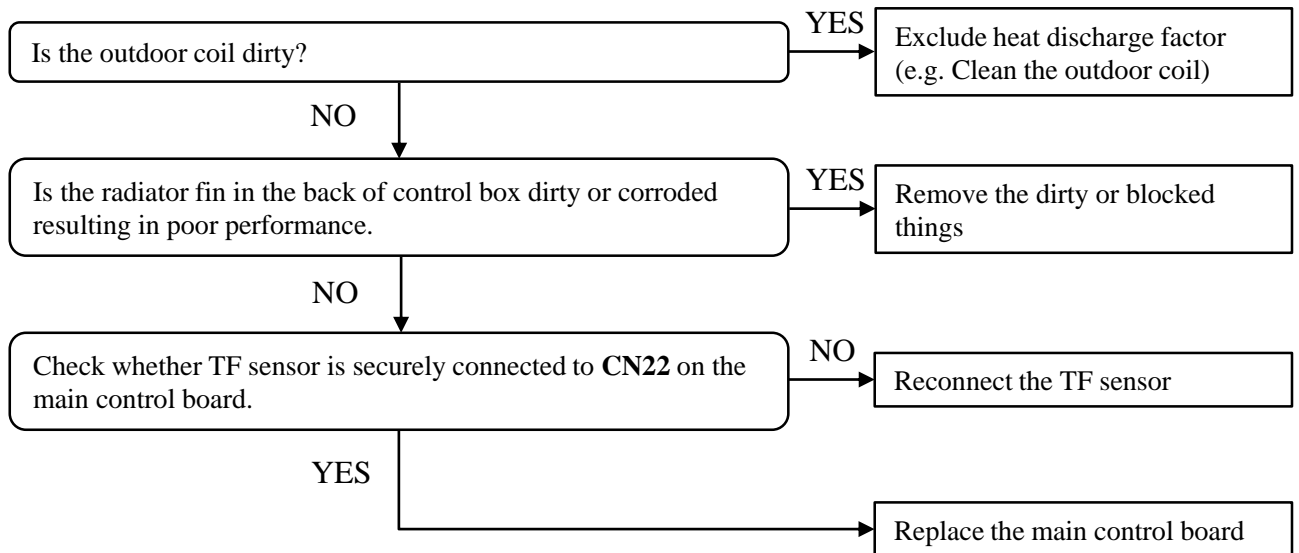
**TIPS:**

Technically measure the DC voltage of the temperature sensor also works when outdoor unit powers on.

Display  **Compressor over-current protection**

1.Error definition:

P6: The detected compressor current is over the maximum allowed value.

EODA18H-2436: 16A

EODA18H-4860: 20A

E6: System locks up when P6 has occurred six times within 3 hours.

2.Possible causes:

- Abnormal power supply voltage
- Too much refrigerant in the system resulting in liquid slugging at compressor
- Damaged main control board
- Indoor unit is suddenly powered off
- Damaged compressor

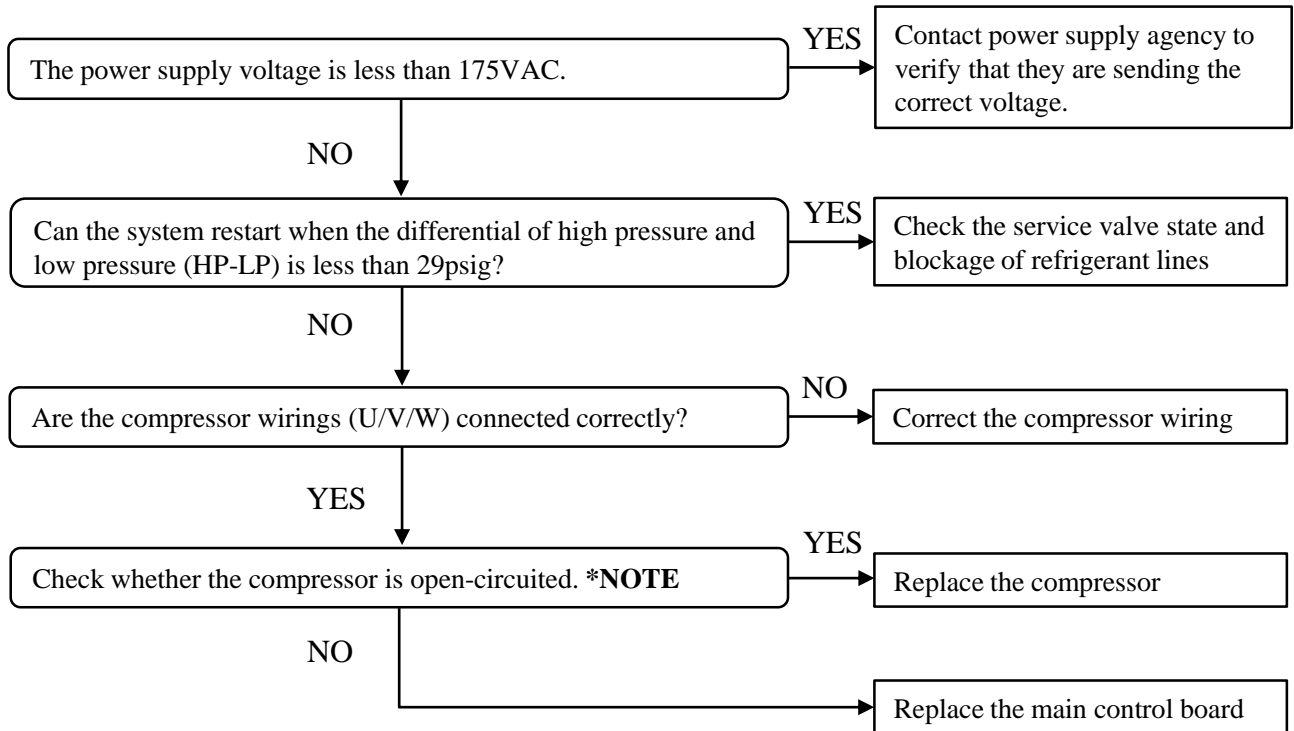
**NOTE: Normal resistance for compressor**

3-phase resistance (UV, UW, VW) for compressor is less than 5Ω.

The insulation resistance (any phase to Ground) for compressor is greater than 100KΩ.

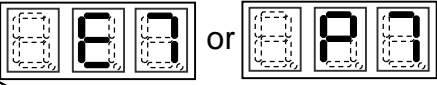
Display  **Liquid slugging protection**

1.Error definition:

This control is to prevent compressor from damaging because of liquid slugging. When $SH < 9.0^{\circ}\text{F}$ and compressor discharge superheat ($DSH = TD - SC - TL - 1.8$) $< 14.4^{\circ}\text{F}$ for 20 minutes, starting to accumulate the liquid slugging time. Report P7 once it lasts for 30 minutes. E7: System locks up when P7 has occurred three times in 5 hours.

2.Possible causes:

- Damaged or improper TXV for indoor unit in cooling mode
- Damaged discharge temperature (TD) sensor
- Overcharged refrigerant
- Damaged EEV of outdoor unit in heating mode
- Damaged main control board

Cooling mode

Connect a pressure gauge at the gas service valve to calculate suction line superheat.

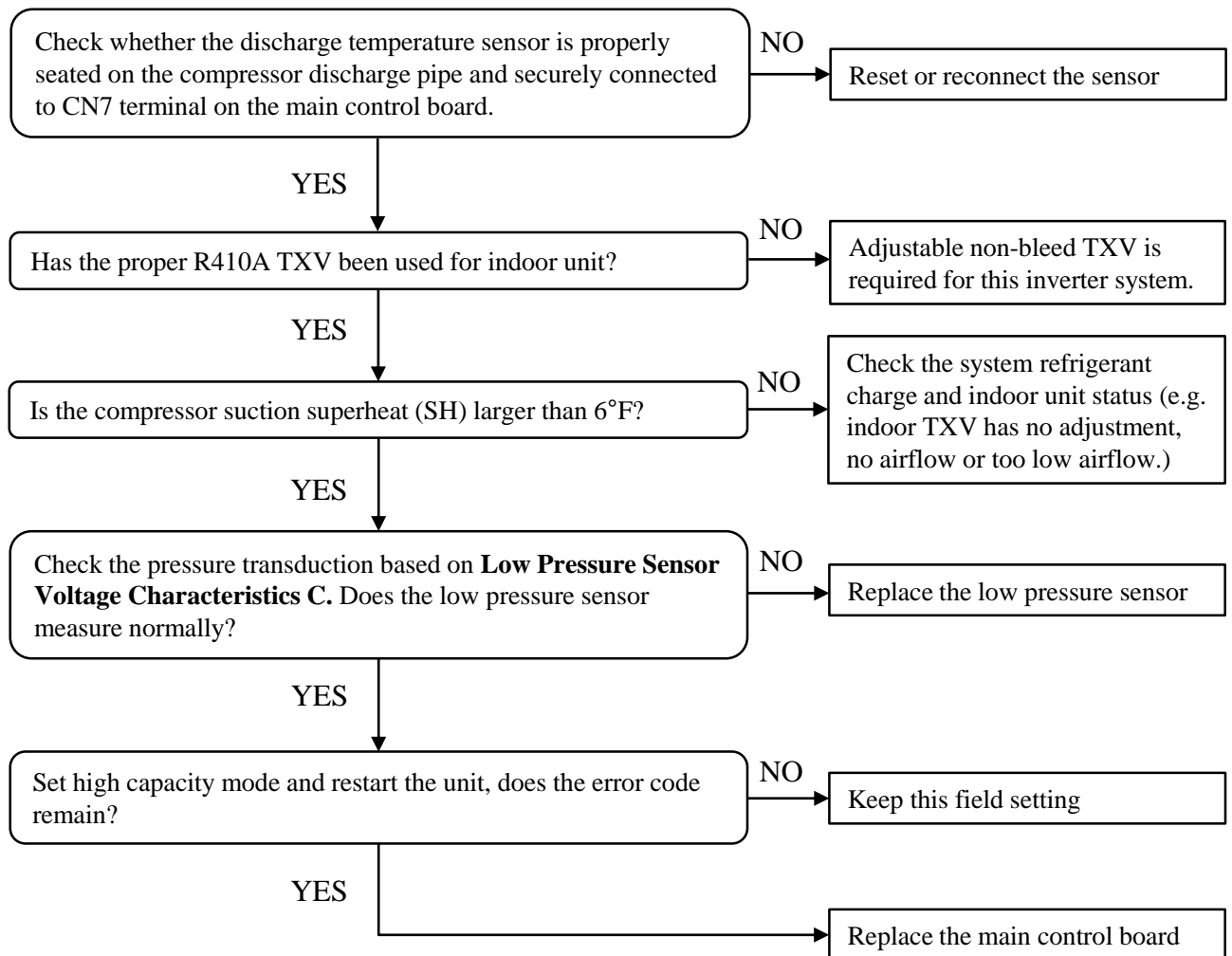

Display

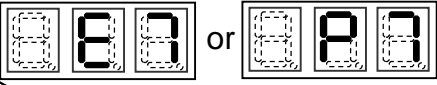

Liquid slugging protection

Heating mode

Connect a pressure gauge to liquid service valve, compare the gauged pressure with the transduced one by high pressure sensor.

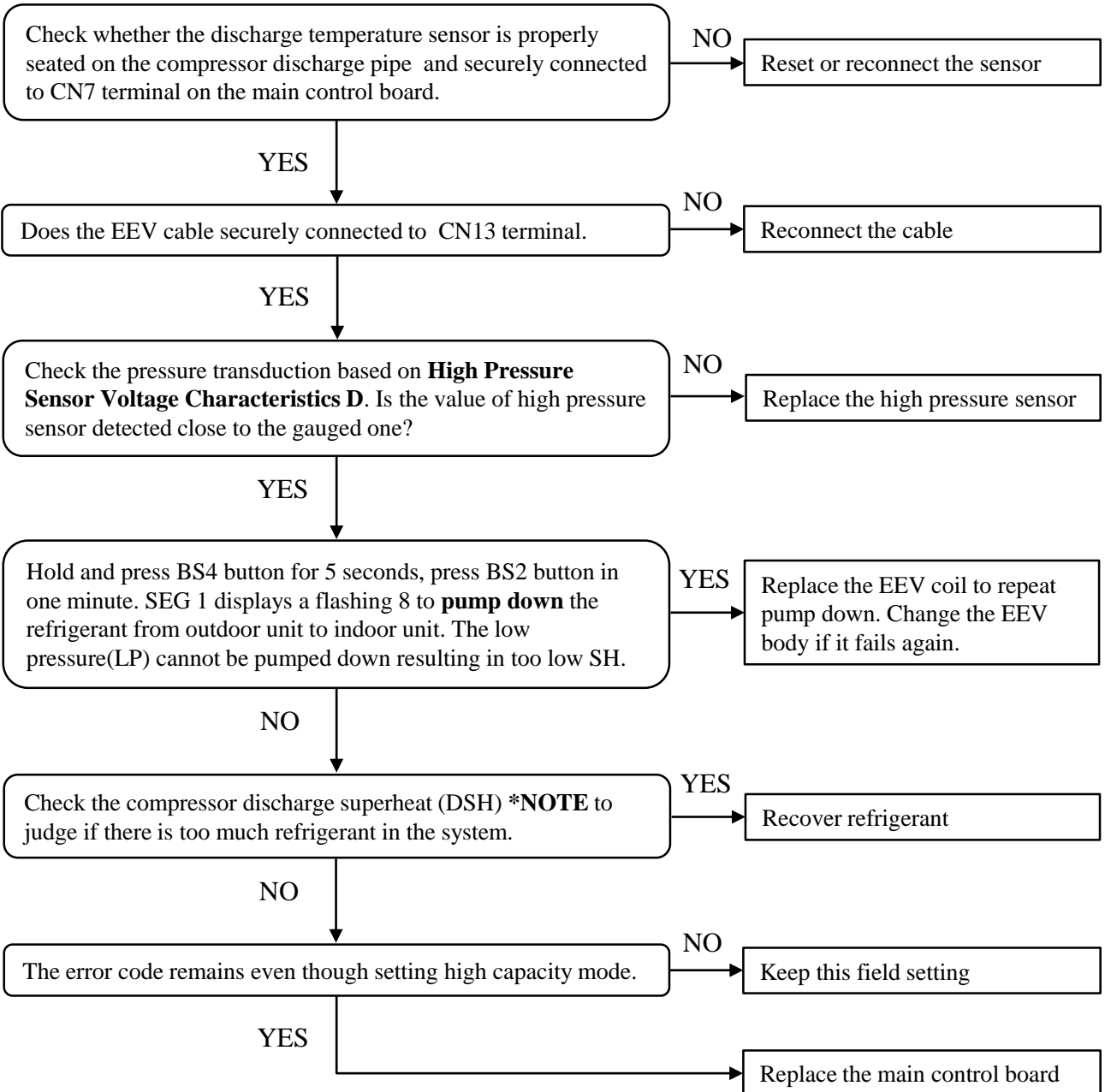

NOTE:

Heating DSH should be between 25 ° F and 50 ° F with proper refrigerant charge in normal control.

Overcharged: DSH is smaller than 18 ° F when the EEV opening < 72pls.
Undercharged: DSH is bigger than 50 ° F when the EEV opening ≥460pls



Display  **Low compressor voltage protection**

1.Error definition:

P8: The detected compressor voltage by main chip is less than 310VDC.

E8: System locks up when P8 has occurred three times in 60 minutes.

2.Possible causes:

- Abnormal power supply voltage
- Damaged main control board

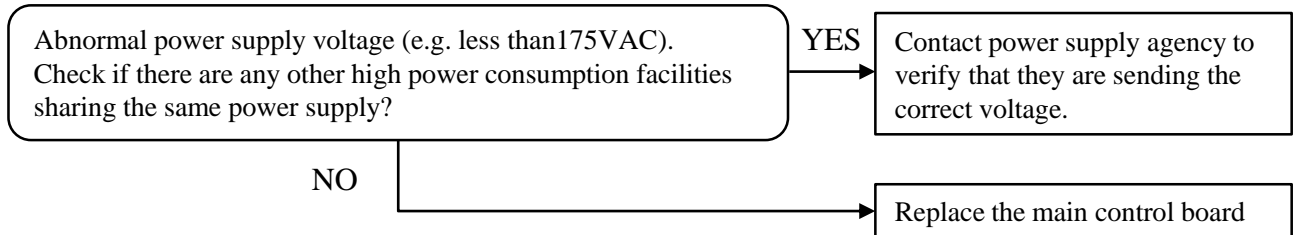

Display  **Incorrect compressor line sequence**

1.Error definition:

The detected compressor line sequence is incorrect for it's difficult to build pressure difference.

2.Possible causes:

- Damaged pressure sensor
- Incorrect U/V/W connections between main control board and compressor terminals
- Damaged EEV or indoor TXV
- Damaged main control board

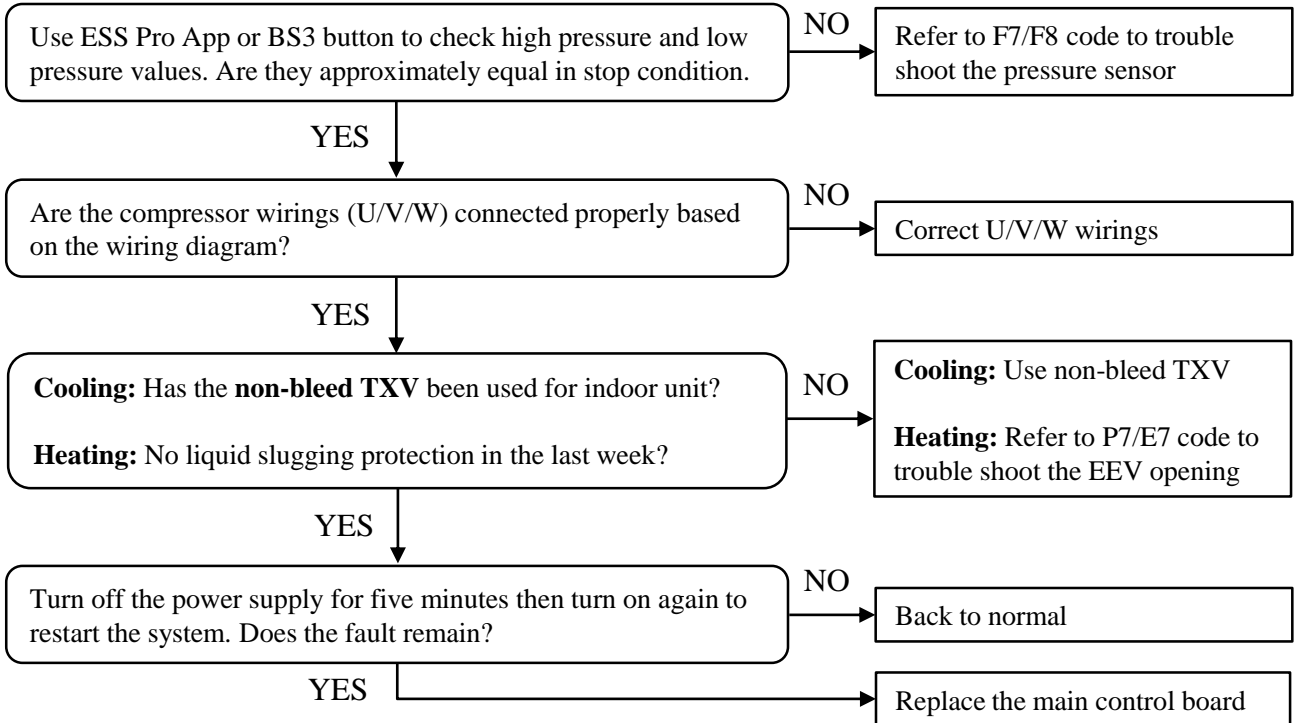

Display

DC fan motor over-load protection

1.Error definition:

- The fan rotation speed is less than 240RPM if it has the running signal.
- The rotation speed difference between the detected value and target one is over 200RPM for 3 minutes.

2.Possible causes:

- Damaged main control board
- Malfunction of fan motor
- The unit is undergoing hurricane
- Disconnected wiring between fan motor and main control board

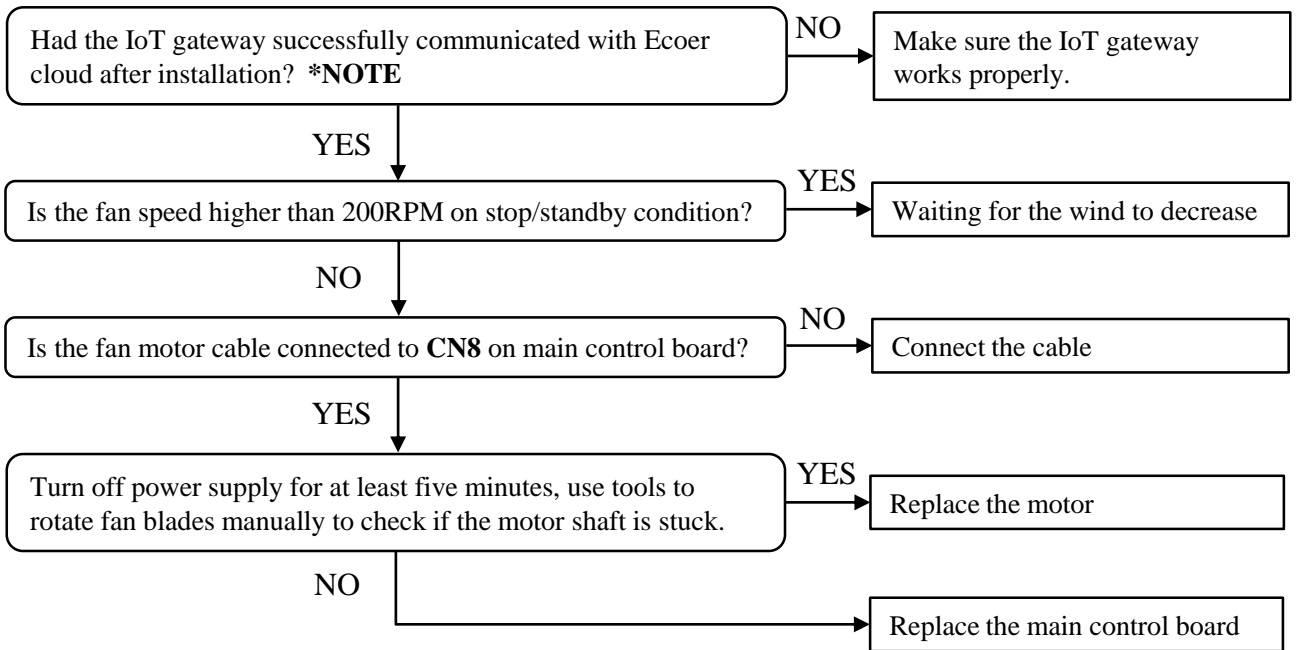

NOTE:

The normal working state of IoT gateway should be blue LED (No.1) is blinking with other LEDs are off.



Display

Ambient temperature(TA) sensor fault

1.Error definition:

The outside temperature(TA) sensor is short circuit or open circuit.

2.Possible causes:

- Damaged main control board
- Loose connection at port on main control board
- Damaged temperature sensor
- There are other heat sources around the sensor

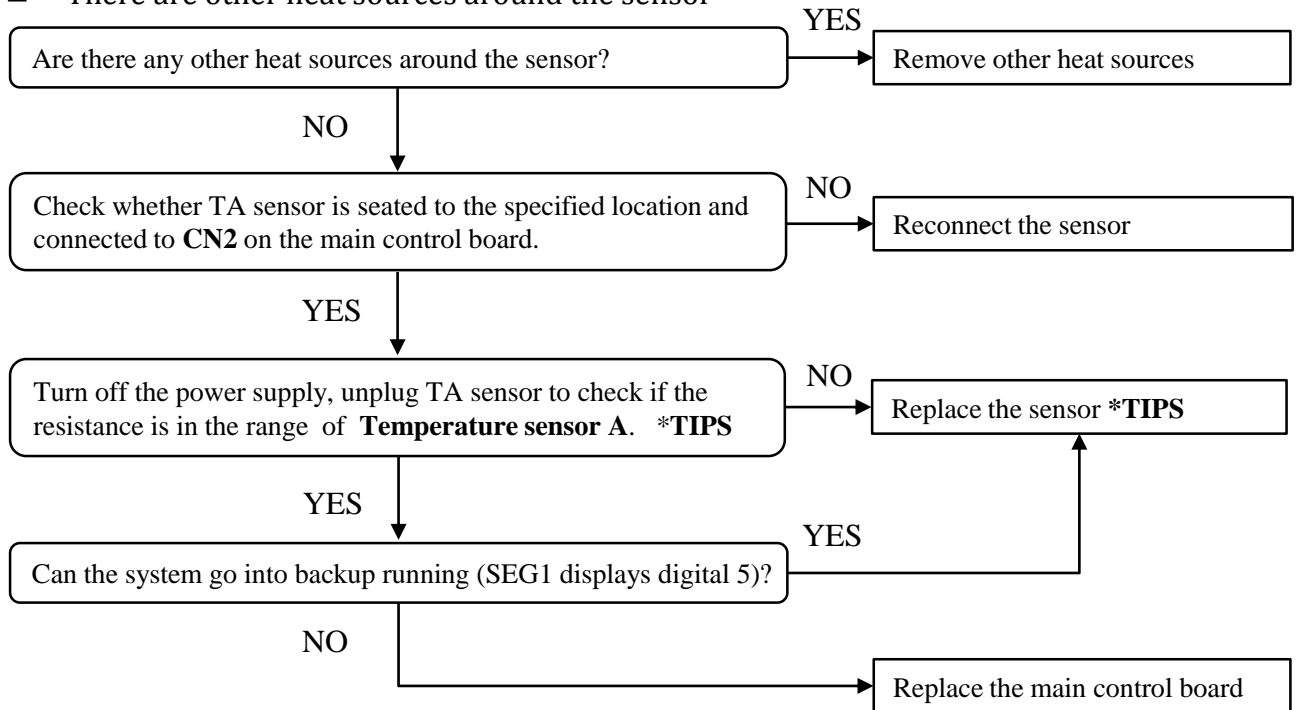

TIPS:

Measure the DC voltage of the temperature sensor also works when outdoor unit powers on.

How to take out the protection cover for TA sensor?

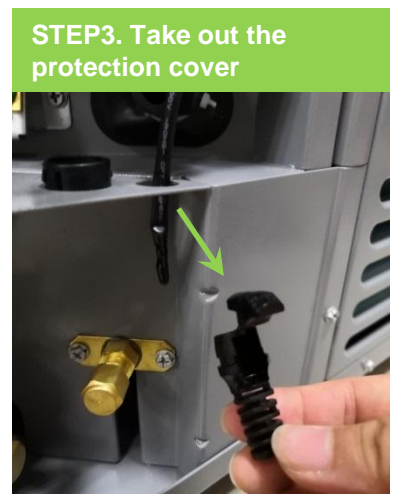
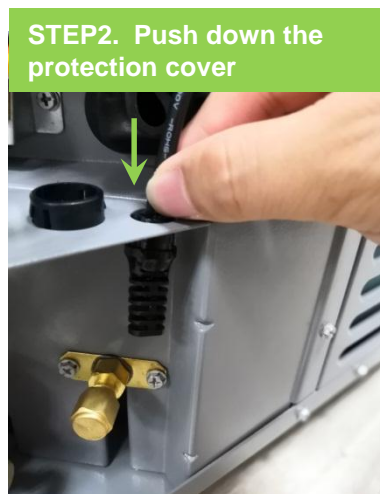
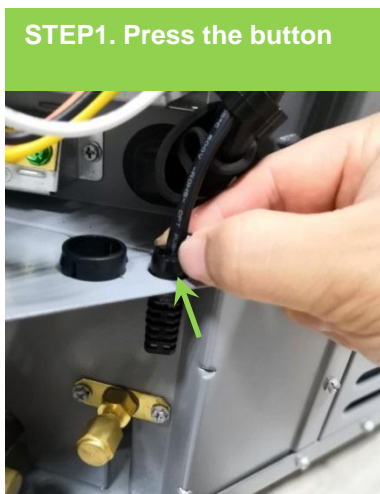

Display

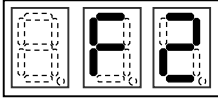

Compressor suction temperature(TS) sensor fault

1.Error definition:

The suction temperature(TS) sensor is short circuit or open circuit.

2.Possible causes:

- Damaged main control board
- Loose connection at port on main control board
- Damaged temperature sensor(TS)
- There are other heat sources around the sensor

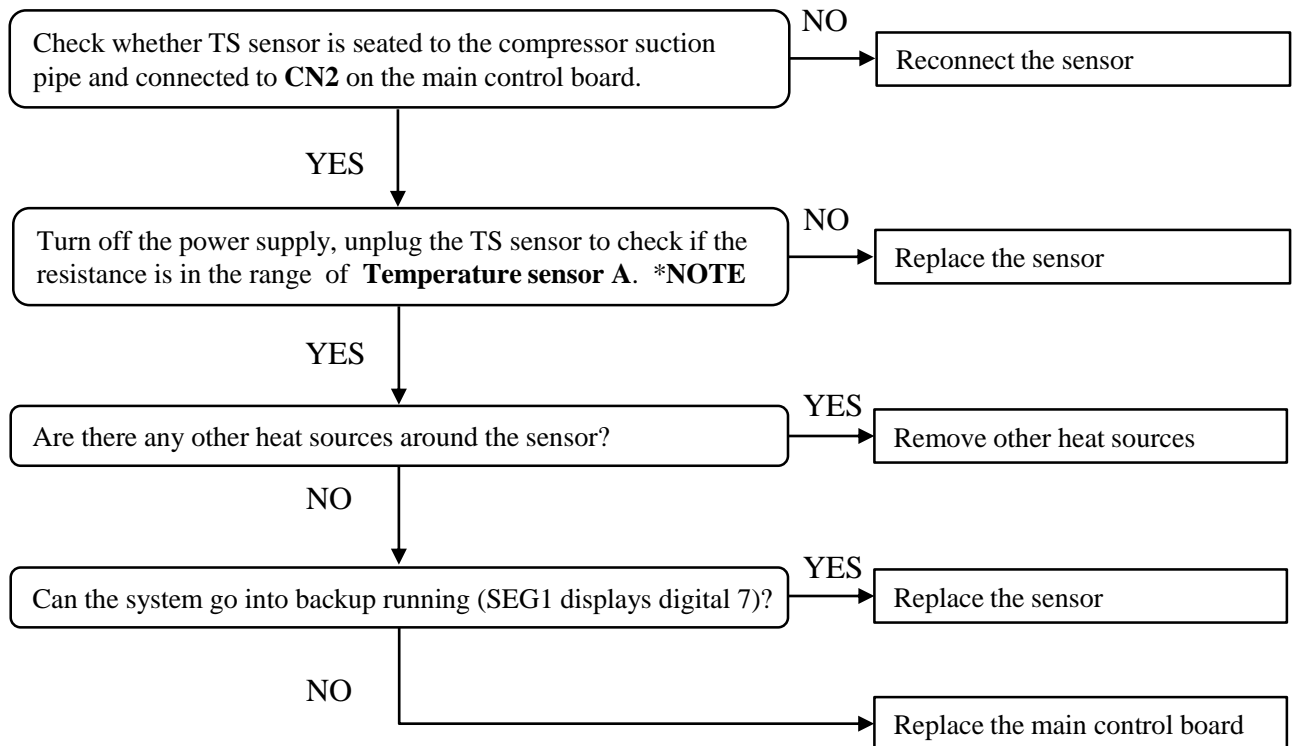

NOTE: Measure the DC voltage of the temperature sensor also works when outdoor unit powers on.

Display

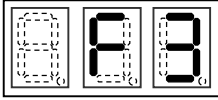

Liquid line temperature(TL) sensor fault

1.Error definition:

The liquid temperature(TL) sensor is short circuit or open circuit.

2.Possible causes:

- Damaged main control board
- Loose connection at port on main control board
- Damaged temperature sensor
- There are other heat sources around the sensor

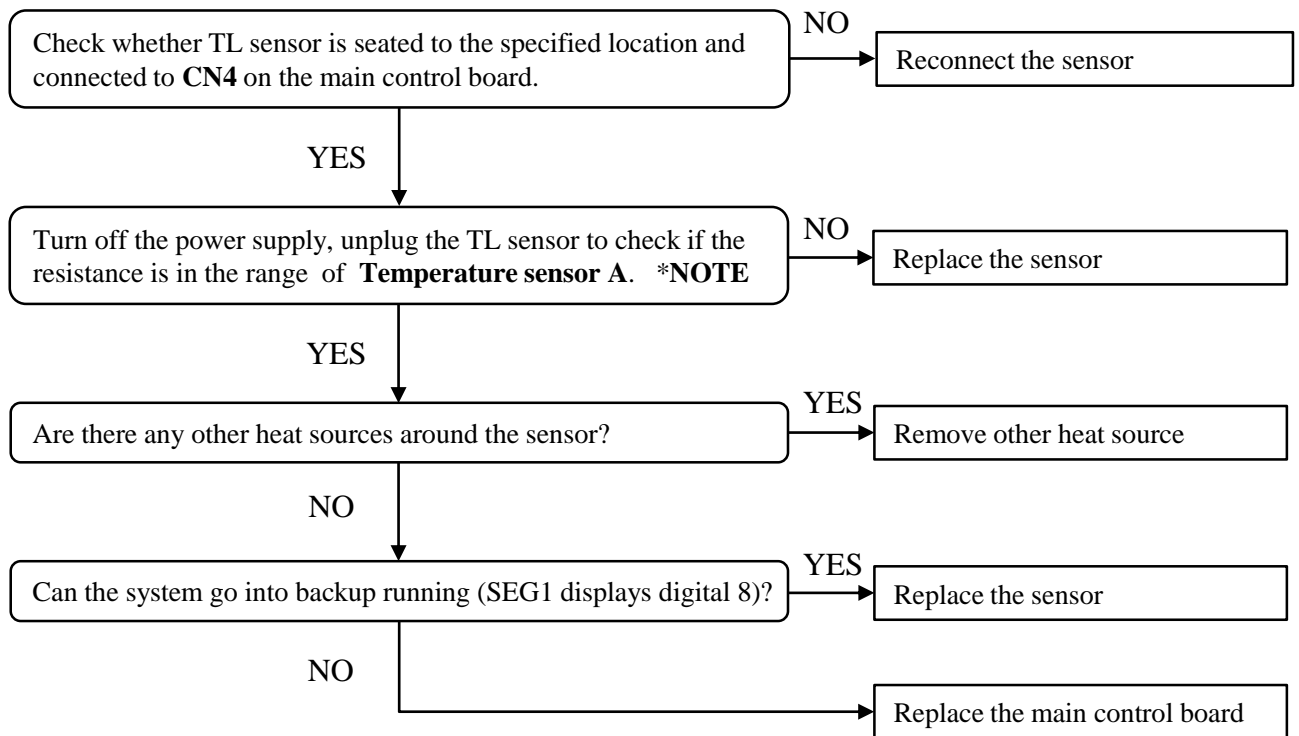

NOTE: Measure the DC voltage of the temperature sensor also works when outdoor unit powers on.

Display

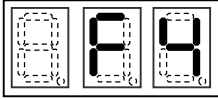

Defrost temperature(TH) sensor fault

1.Error definition:

The defrost temperature(TH) sensor is short circuit or open circuit.

2.Possible causes:

- Damaged main control board
- Loose connection at port on main control board
- Damaged temperature sensor
- There are other heat sources around the sensor

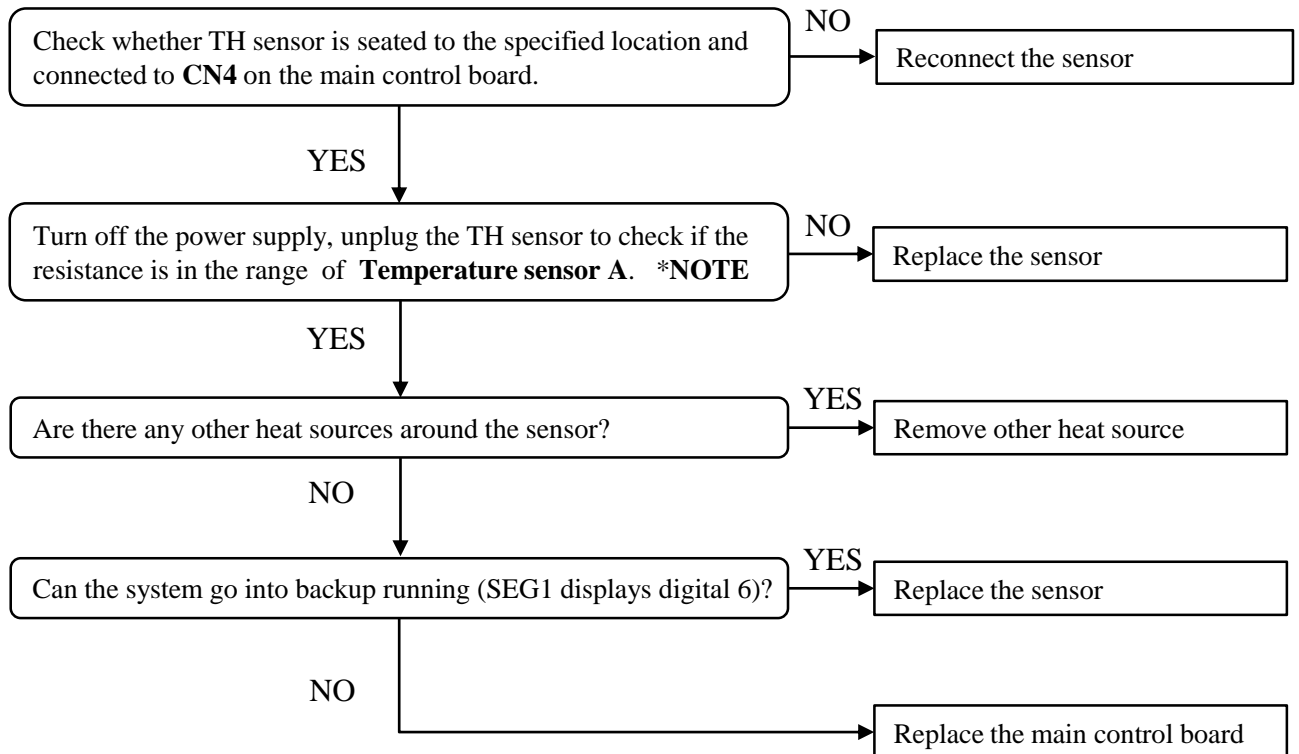

NOTE: Measure the DC voltage of the temperature sensor also works when outdoor unit powers on.

Display

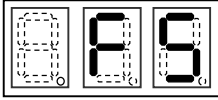

Compressor discharge temperature(TD) sensor fault

1.Error definition:

The discharge temperature(TD) sensor is short circuit or open circuit.

2.Possible causes:

- Damaged main control board
- Loose connection at port on main control board
- Temperature sensor failure
- There are other heat sources around the sensor

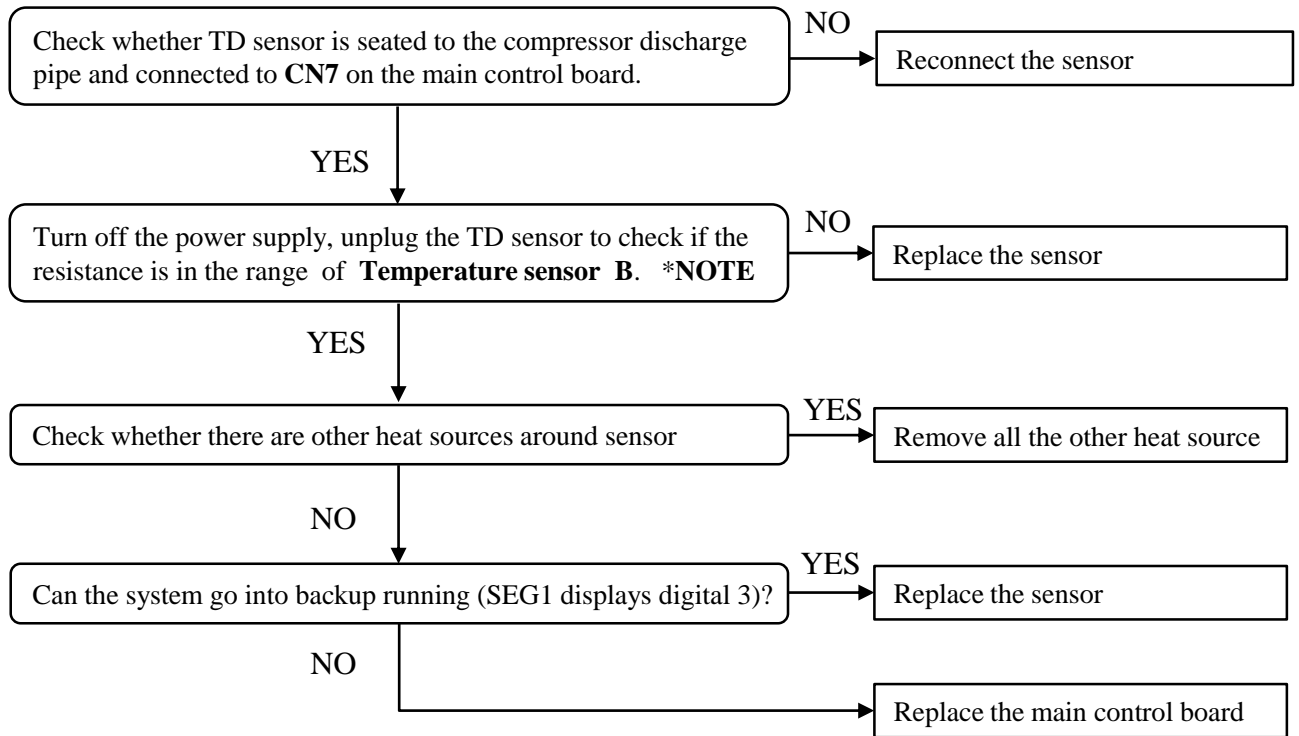

NOTE: Measure the DC voltage of the temperature sensor also works when outdoor unit powers on.

Display

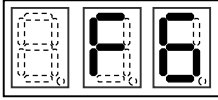

Inverter module temperature(TF) sensor fault

1.Error definition:

The module temperature(TF) sensor is short circuit or open circuit.

2.Possible causes:

- Damaged main control board
- Loose connection at port on main control board.
- Temperature sensor failure
- There are other heat sources around the sensor

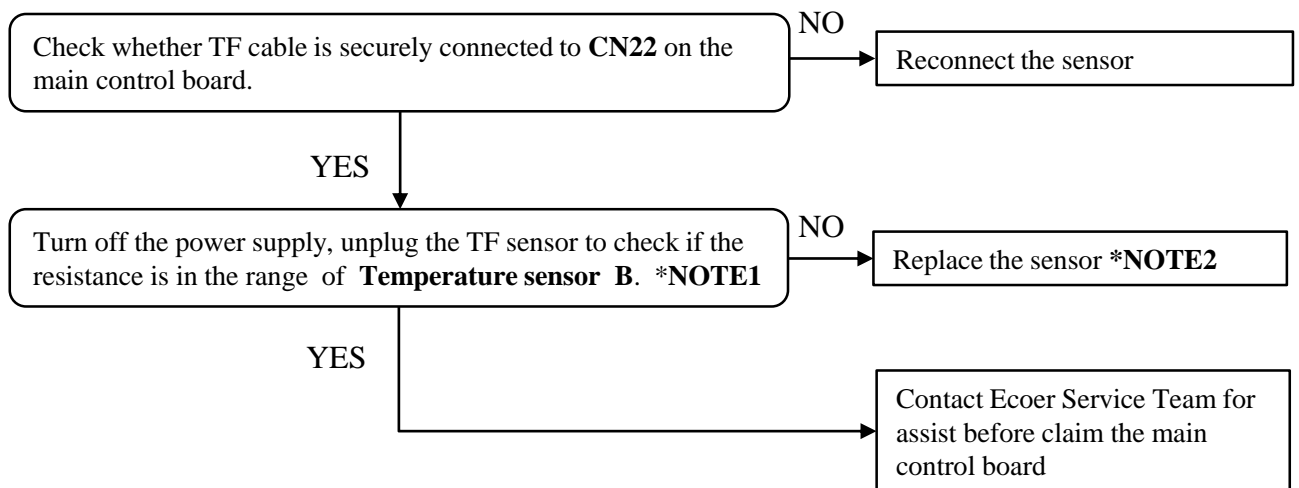

NOTES:

1. Measure the DC voltage of the temperature sensor also works when outdoor unit powers on.
2. TF sensor has been laid inside the assembly control box with silicon gel contacting the radiator. It's required to replace the main control board in this case.

Display



High pressure(HP) sensor fault

1.Error definition and method to check:

The high pressure sensor is open or shorted.

The voltage between CN10 pin(1) and (2) is not in the range 0.59~4.76VDC.

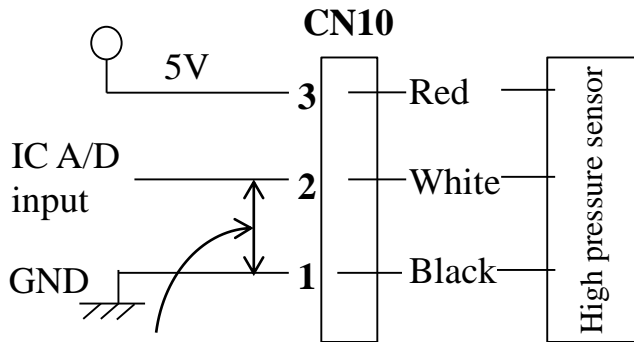

Measure DC voltage within these pins

2.Possible causes:

- Damaged main control board
- Loose connection at port on main control board
- Damaged high pressure sensor
- Too little refrigerant remains in the system

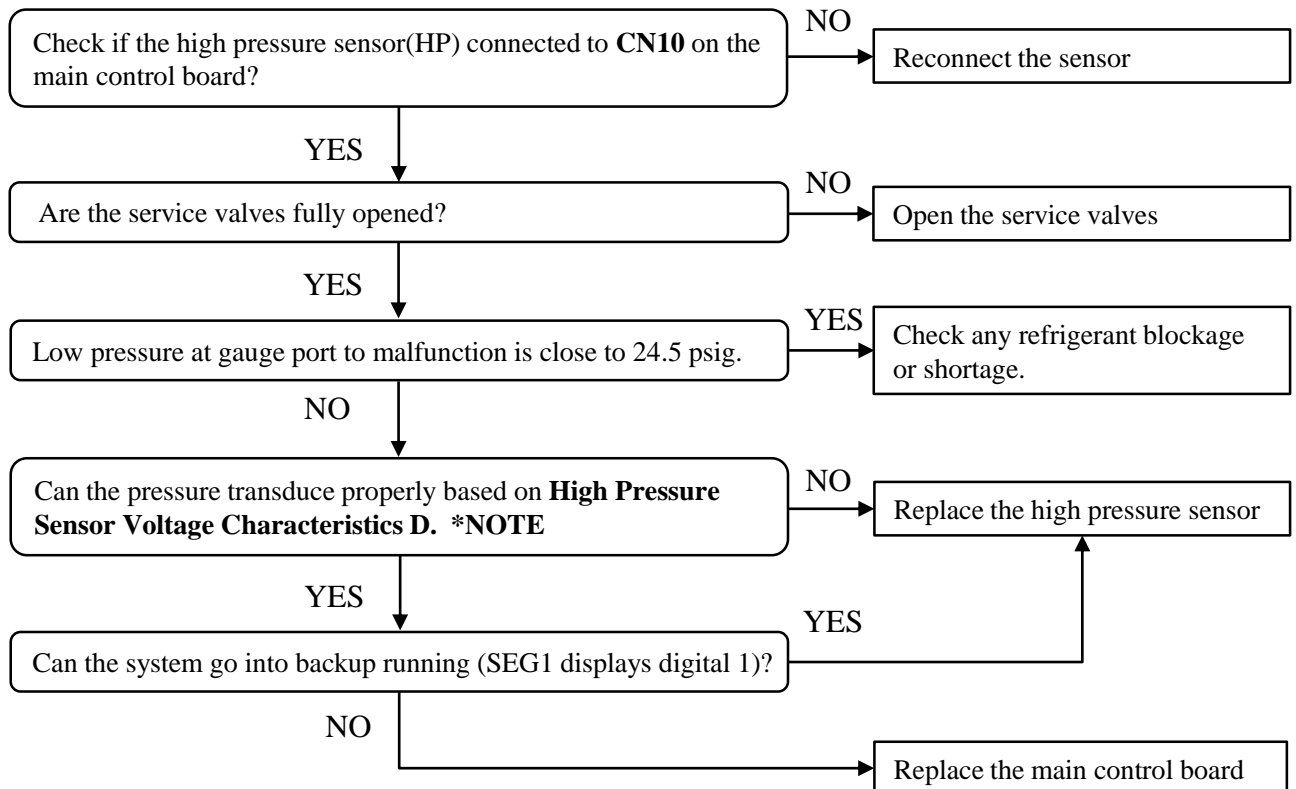

NOTE:

Connect a pressure gauge to liquid service valve in cooling mode, gas service valve in heating mode. Compare the value difference between gauged pressure and the transduced one by high pressure sensor (spot check by BS3 button or check the data from ESS Pro App).

Display

Low pressure(LP) sensor fault

1. Error definition and method to check:

The low pressure sensor is open or shorted.

The voltage between CN9 pin(1) and (2) is not in the range 0.70~4.50VDC.

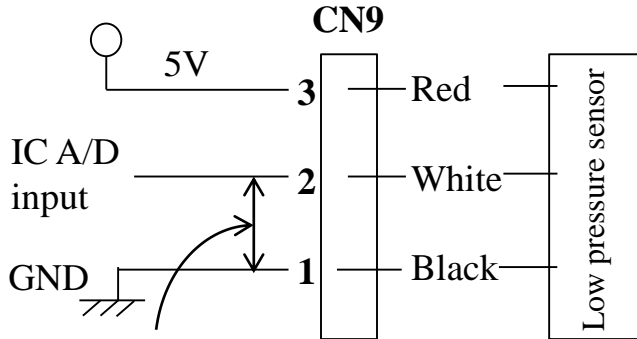

Measure DC voltage within these pins

2. Possible causes:

- Damaged main control board
- Loose connection at port on main control board
- Damaged low pressure sensor
- Too little refrigerant remains in the system

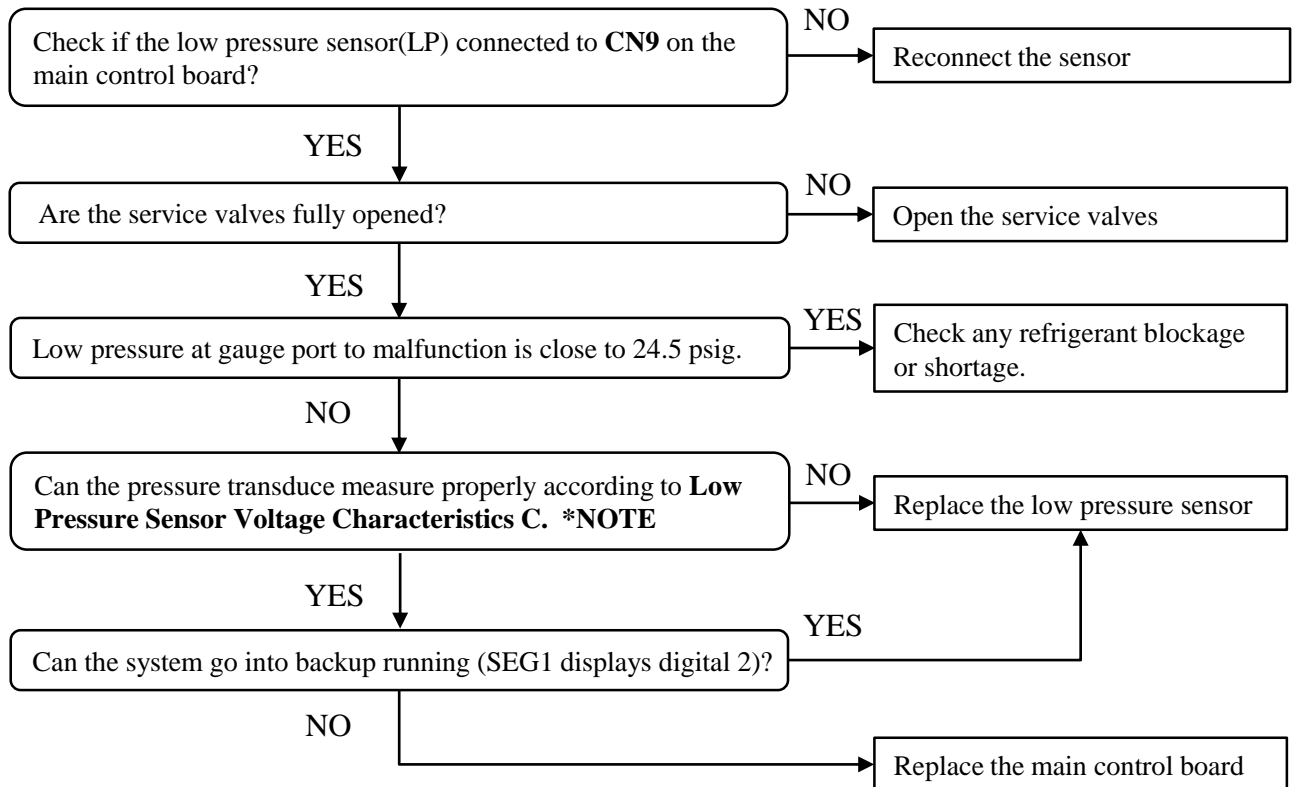

NOTE:

Connect a pressure gauge to gauge port, compare the difference between the gauged pressure and the transduced one by low pressure sensor (spot check by BS3 button or check the data from ESS Pro App).

Display

Communication fault between main chip and INV drive chip

1.Error definition and method to check:

Communication fault between the main control chip and inverter chip.

2.Possible causes:

- Loose connection at CN21 terminal
- Damaged main control board

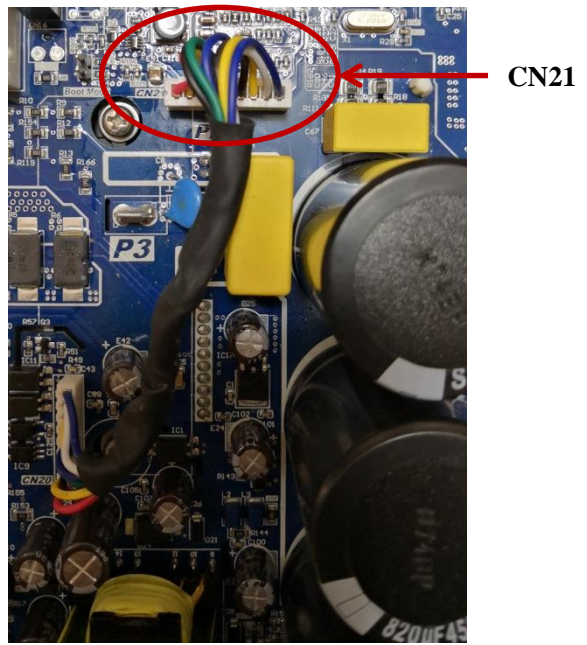
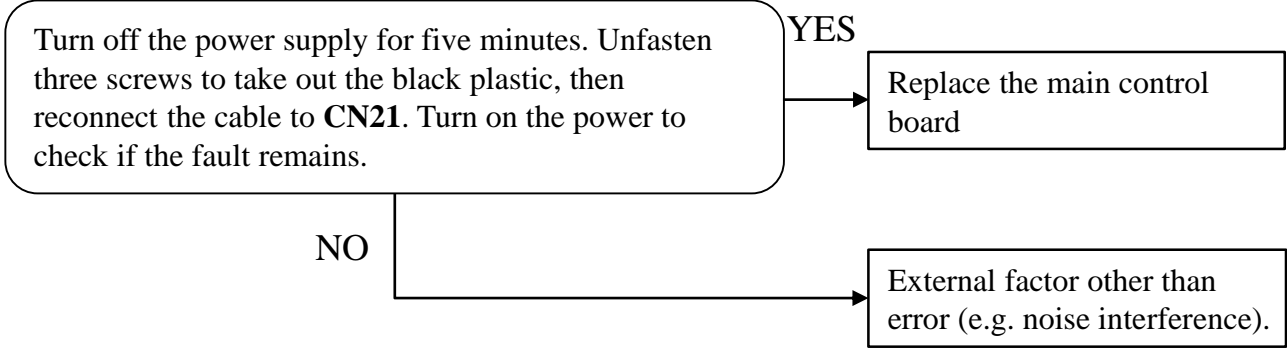

Display



Ambient temperature limit operation

1.Error definition and method to check:

H1: The detected ambient temperature is absolutely prohibited for cooling.

$$TA < 32^{\circ}\text{F} \text{ or } \geq 140^{\circ}\text{F}$$

H2: The detected ambient temperature is absolutely prohibited for heating.

$$TA \geq 86^{\circ}\text{F} \text{ or } TA < \text{forced heating stop temperature set by n01}$$

2.Possible causes:

- The ambient temperature exceeds the set range of operation.
- The system is running previous mode
- Damaged ambient temperature sensor (TA)
- Damaged main control board.

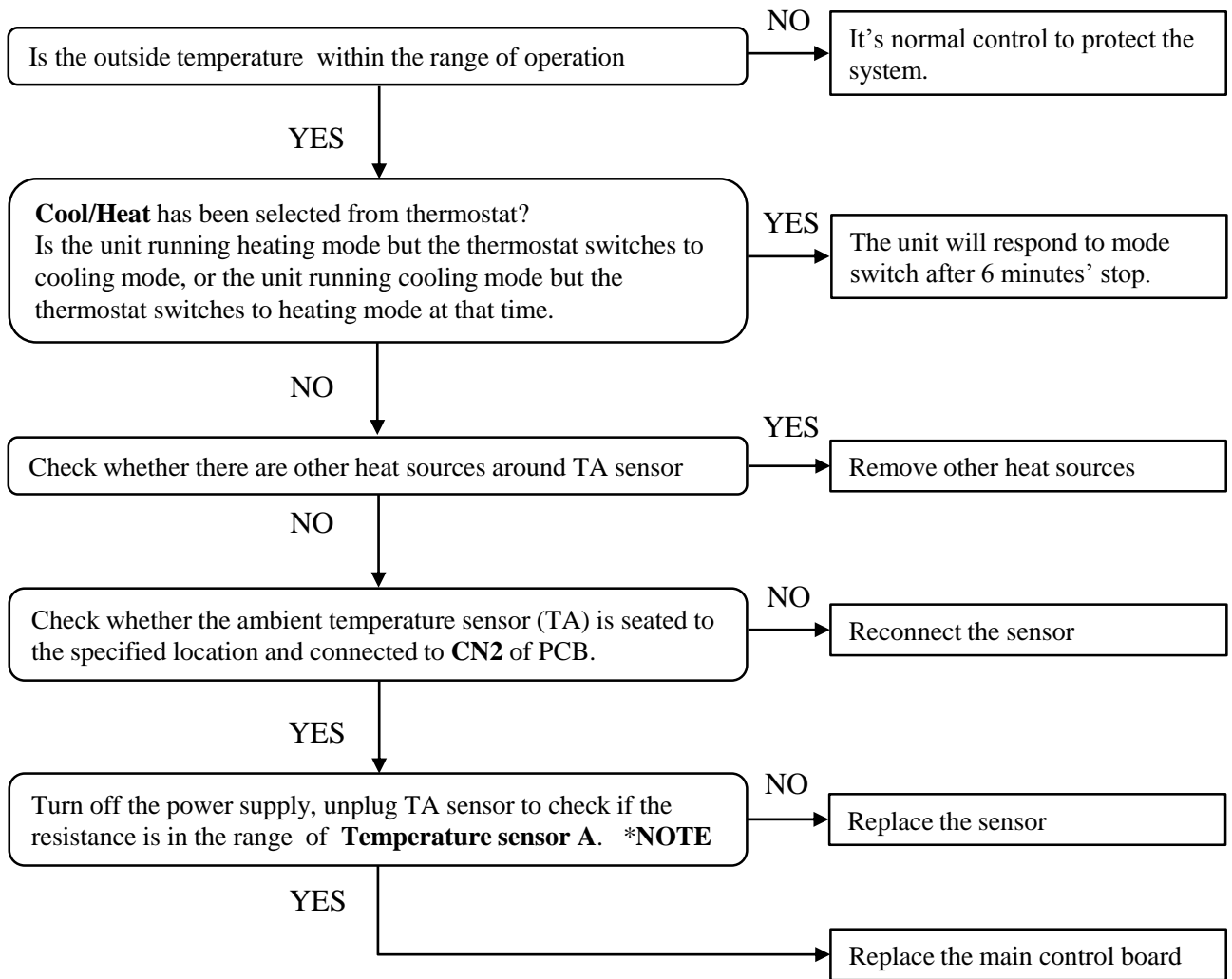

Display

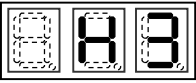

Abnormal switch alarm for 4-way valve

1.Error definition:

4-way valve switches incompletely after defrost operation or from cooling mode.
Report H3 alarm if $TH \geq TL + 10.8^{\circ}F$ and $TH \geq TA + 5.4^{\circ}F$.

2.Possible causes:

- Damaged 4-way valve(coil or body)
- Damaged main control board
- Abnormal voltage of power supply
- Temperature sensor(TH) failure
- Reversed location between TH and TL

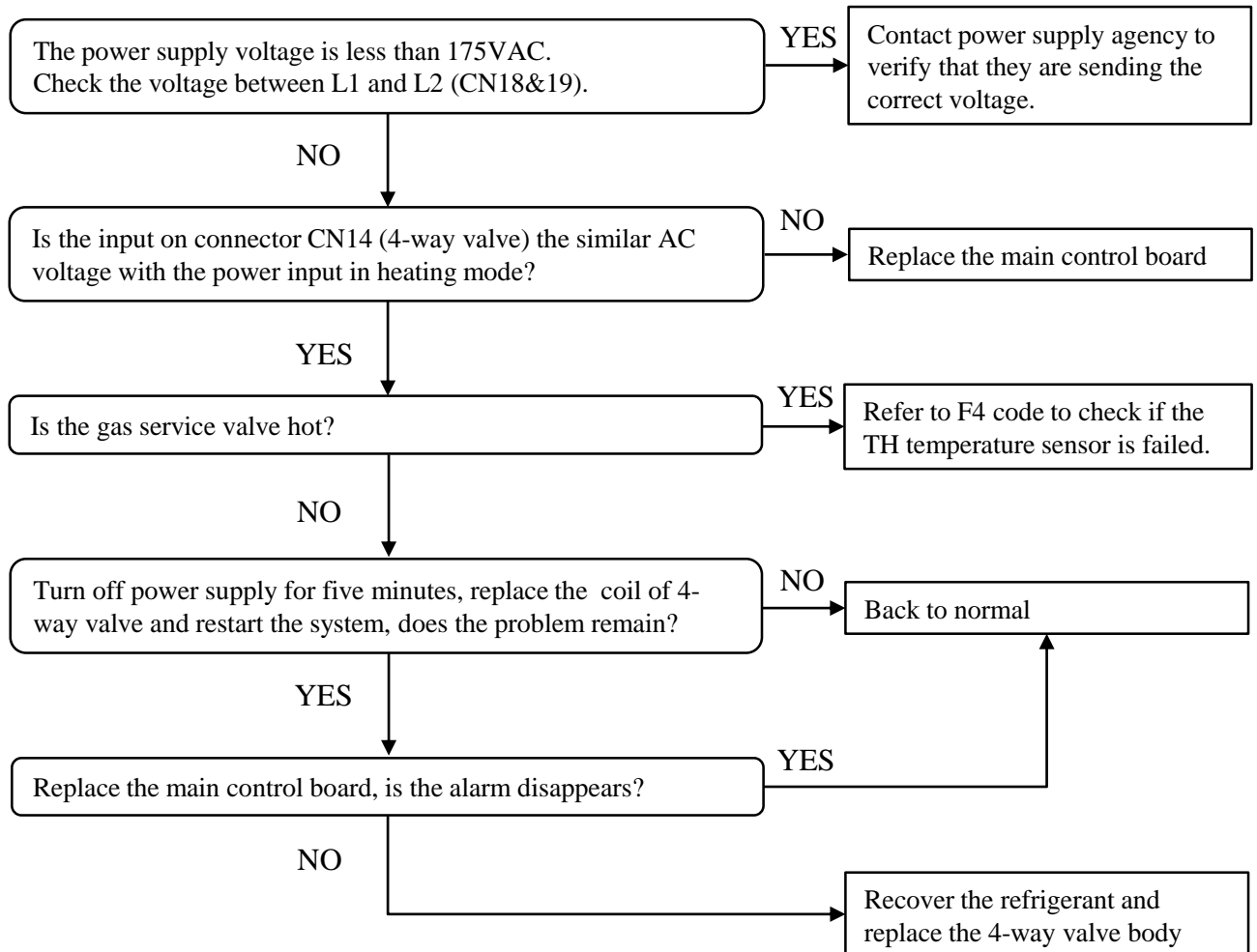

Display

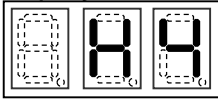

Defrost temperature(TH) sensor is disconnected or damaged

1.Error definition:

The defrost temperature(TH) sensor is short circuit or open circuit.

2.Possible causes:

- Damaged main control board
- The defrost temperature sensor is wrongly seated
- Temperature sensor failure
- There are other heat sources around the sensor

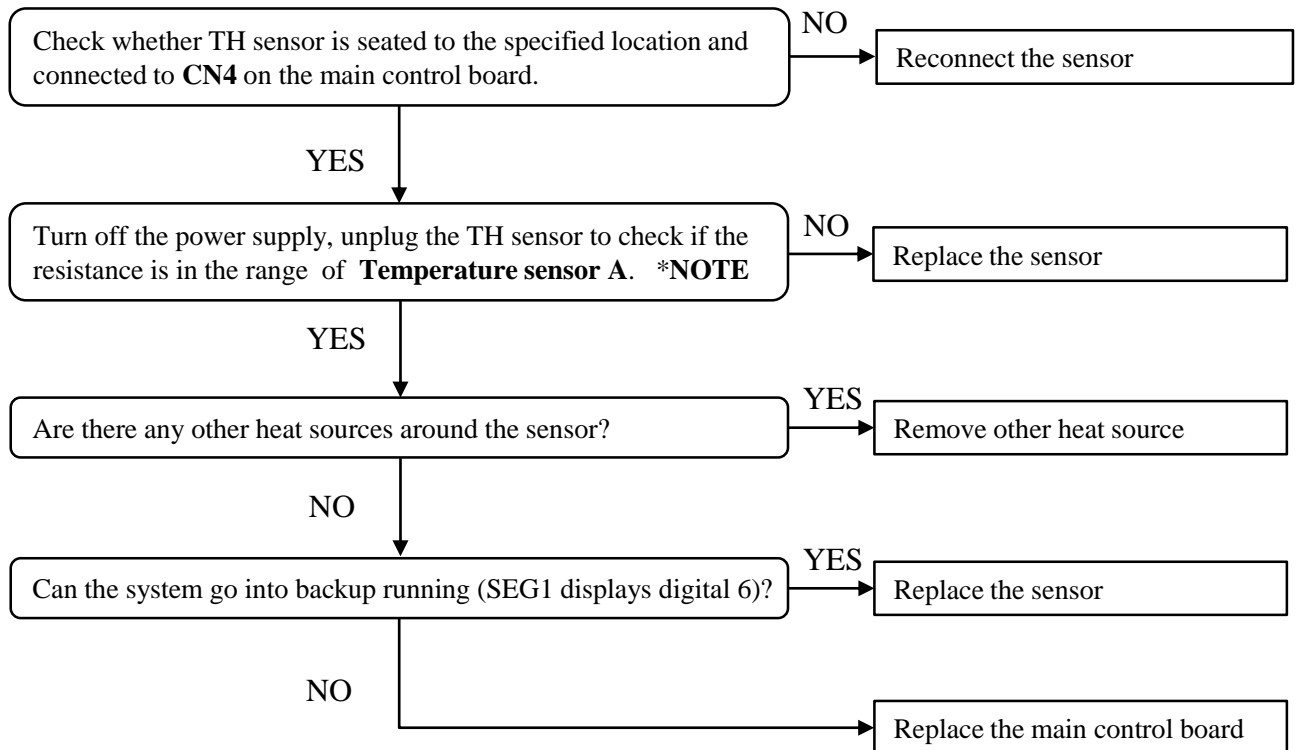

NOTE: Measure the DC voltage of the temperature sensor also works when outdoor unit powers on.

Display

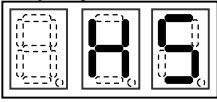

EEPROM fault

1.Error definition:

Data cannot be correctly received from the EEPROM to main chip.

EEPROM, a type of memory component, remembers contents even though power off.

2.Possible causes:

- Damaged main control board

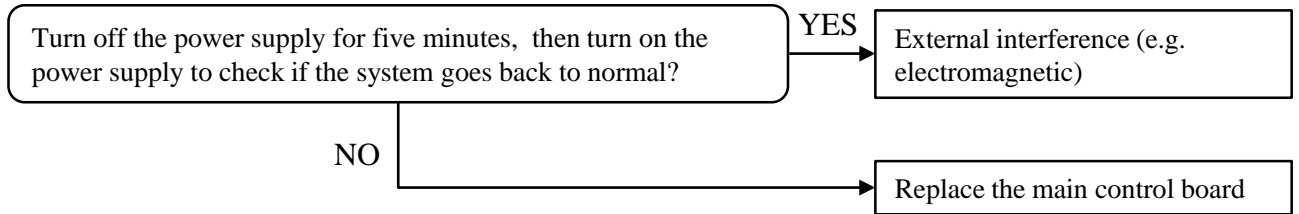

Display

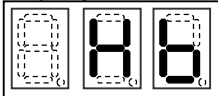

Low voltage alarm

1.Error definition:

Power supply voltage is less than 175VAC.

2.Possible causes:

- Abnormal power supply voltage
- Damaged main control board

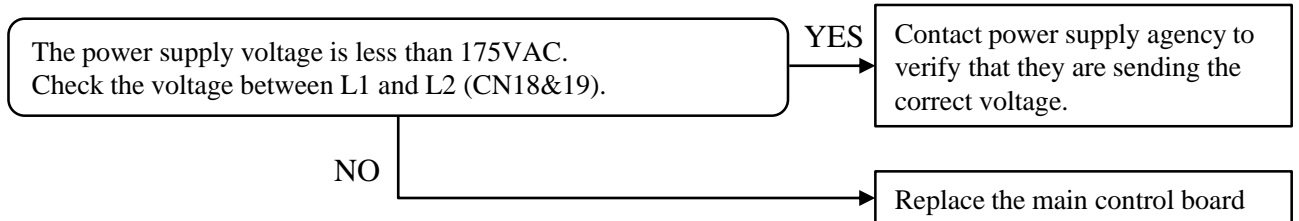

Display

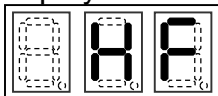

Abnormal function control

1.Error definition:

Cannot exit special control (start-up, oil return or defrost)

2.Possible causes:

- Abnormal signal input from thermostat

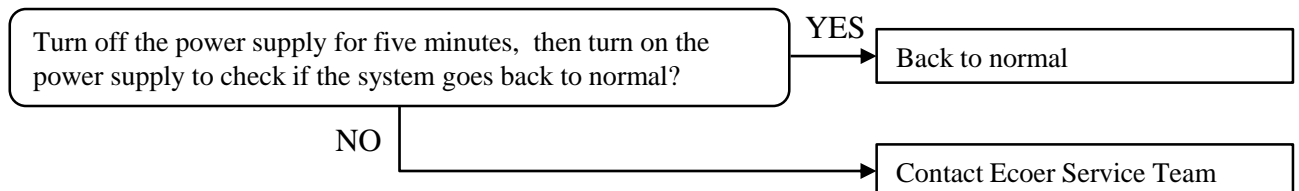

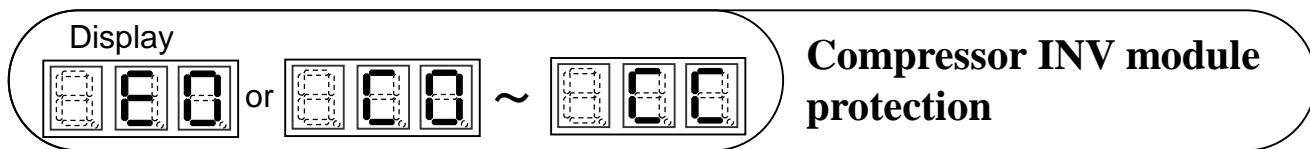

1.Error definition:

Code	LED Display	Definition
C0		Critical over-voltage fault
C1		DC bus over-voltage protection
C2		DC bus under-voltage protection
C3		Over-current protection
C4		Zero speed fault
C7		Compressor speed inconsistent fault
C9		Compressor speed difference between given transient variation and actual operation
CA		AC over-voltage protection
CB		AC under-voltage protection
CC		PFC error

E0: System locks up when C0~CA has occurred three times in 60 minutes.

2.Possible causes:

- Abnormal power supply voltage
- Power supply disconnected (C2/C7/C9 or C2/C3/C7 report at the same time)
- Dirty compressor terminal or damaged compressor
- Damaged main control board
- Micro channel coil has been used for heat pump

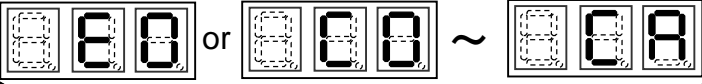
Display  **Compressor INV module protection**

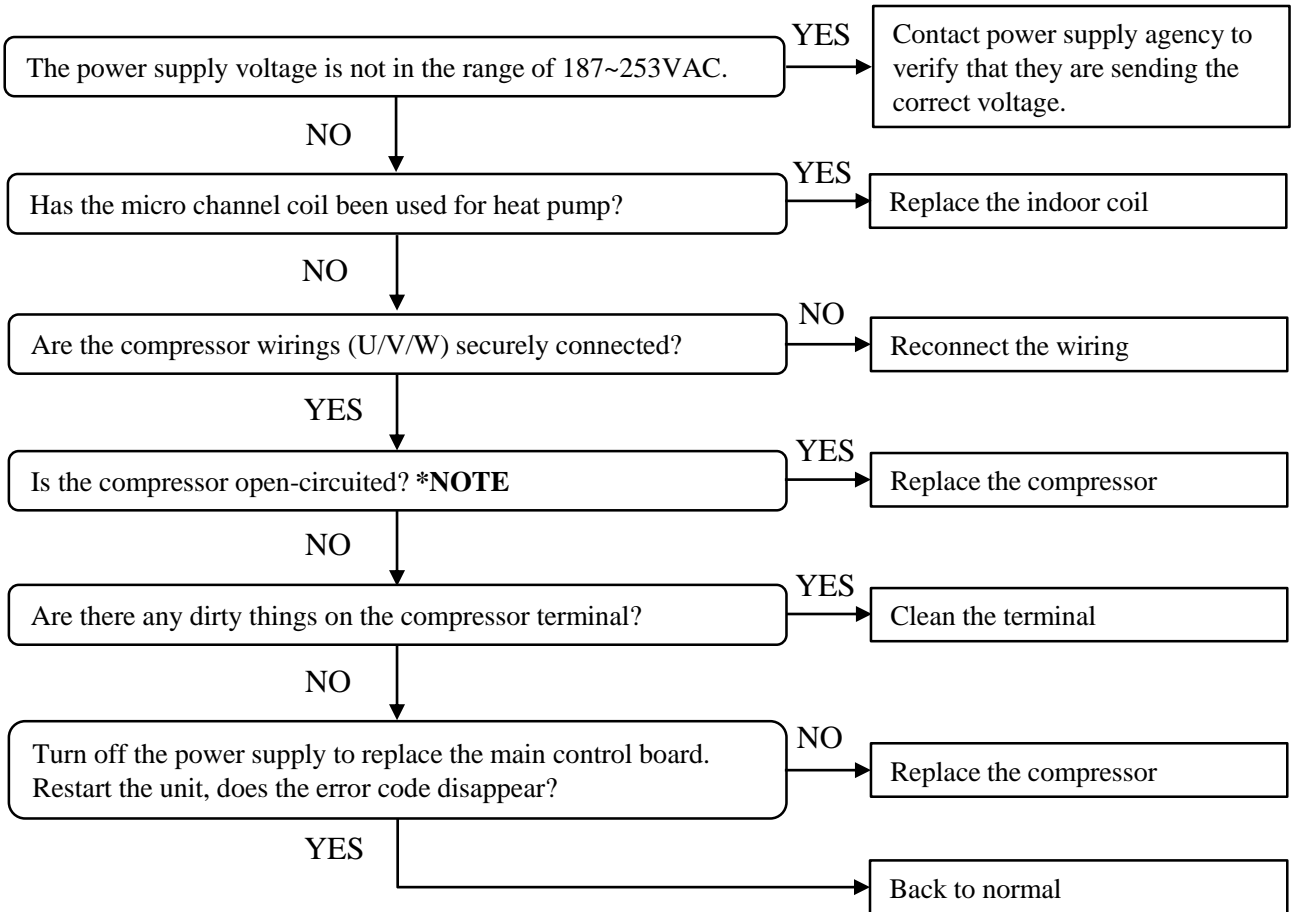

NOTE: Normal resistance for compressor
 3-phase resistance (UV, UW, VW) for compressor is less than 5Ω.
 The insulation resistance (any phase to Ground) for compressor is greater than 100KΩ.

4 Parts List

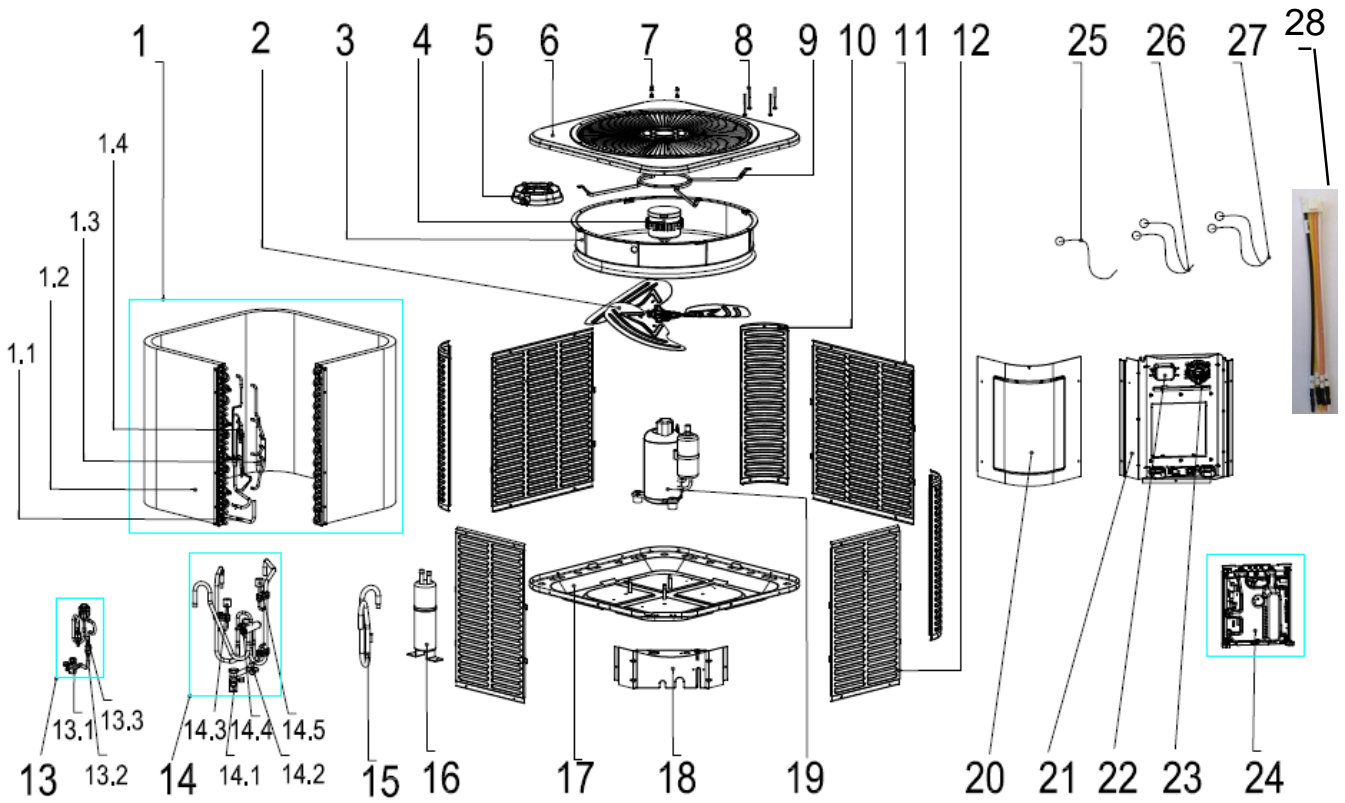

#	Part Name	Quantity	Parts number		Remark
			2436	4860	
1	Condenser ass'y	1	231235269	231235477	
1.1	Condenser connection pipe ass'y	1	231235268		
1.2	Condenser	1	231235270	231235271	
1.3	Condenser outlet pipe ass'y	1	231235085	231235153	
1.4	Condenser inlet pipe ass'y	1	231235084	231235154	
2	Fan	1	230801635		
3	Guide ring	1	230700850		
4	Brushless DC Motor	1	230904010		
5	Motor installation board ass'y	1	230803381		
6	Top cover ass'y	1	230803291		
7	Cap nut	4	230803110		
8	Electrical installation bolt	4	230803111		
9	Roof support frame	1	230801628		
10	Supporting board	3	230801590B	230801609B	

#	Part Name	Quantity	Parts number		Remark
			2436	4860	
11	Side board ass'y	2	230803142	230802064A	
12	Side board ass'y	2	230803143	230802065A	
13	High-pressure valve ass'y	1	231235131	231235854	
13.1	Liquid block valve	1	231231469		
13.2	Electronic expansion valve (EEV)	1	231235157	231235779	
13.3	EEV solenoid coil	1	3120290034		
14	4-way valve ass'y	1	231235265	231235155	
14.1	Gas block valve	1	231231468	3120130060	
14.2	Pipe joint ass'y	1	231235472	231235471	
14.3	High pressure sensor (black)	1	231235159		
14.4	4-way valve	1	231235077 231235079	231235078 231235079	231235077-valve body 231235078-valve body 231235079-valve coil
14.5	Low pressure sensor (green)	1	231235158		
15	Suction pipe ass'y	1	231235421	231235149	
16	Refrigerant accumulator	1	231236288	231236289	
17	Chassis Parts	1	230803293		
18	Lower side plate	1	230803138	230803139	
19	Compressor	1	231235530	231235532	
20	Upper cover plate	1	230803313	230803309	
21	Electrically controlled mounting board	1	230803312	230803310	
22	Noise filter	1	230904159		
23	PFC inductor	1	230904160	230904161	
24	Motherboard component	1	230904156	230904157	
25	Discharge Temp. sensor	1	3160130008A		TD temperature sensor
26	Pipe Temp. sensor ass'y	1	230901018		TL temperature sensor TH temperature sensor
27	Temp. sensor ass'y	1	230901233		TS temperature sensor TA temperature sensor
28	Thermostat wiring connector	1	230904254		To thermostat

5 Appendix

5.1 Sensor Characteristic

Temperature sensor A* (TS,TH,TA,TL)

Temp. (°C)	Temp. (°F)	Resistance (KΩ)	Voltage (V)
-20	-4	104.86	0.53
-19	-2.2	98.84	0.56
-18	-0.4	93.21	0.58
-17	1.4	87.93	0.61
-16	3.2	82.98	0.64
-15	5	78.33	0.67
-14	6.8	73.97	0.70
-13	8.6	69.88	0.73
-12	10.4	66.03	0.77
-11	12.2	62.42	0.80
-10	14	59.02	0.84
-9	15.8	55.82	0.87
-8	17.6	52.81	0.91
-7	19.4	49.98	0.94
-6	21.2	47.32	0.98
-5	23	44.81	1.02
-4	24.8	42.45	1.06
-3	26.6	40.22	1.10
-2	28.4	38.12	1.14
-1	30.2	36.15	1.18
0	32	34.28	1.22
1	33.8	32.52	1.26
2	35.6	30.86	1.30
3	37.4	29.29	1.34
4	39.2	27.81	1.38
5	41	26.42	1.42
6	42.8	25.10	1.46
7	44.6	23.85	1.51
8	46.4	22.67	1.55
9	48.2	21.56	1.59
10	50	20.50	1.63
11	51.8	19.51	1.67
12	53.6	18.56	1.71
13	55.4	17.67	1.75
14	57.2	16.83	1.79
15	59	16.03	1.83
16	60.8	15.27	1.87
17	62.6	14.55	1.91
18	64.4	13.87	1.95
19	66.2	13.23	1.99
20	68	12.62	2.02
21	69.8	12.04	2.06

Temp. (°C)	Temp. (°F)	Resistance (KΩ)	Voltage (V)
22	71.6	11.49	2.10
23	73.4	10.97	2.13
24	75.2	10.47	2.17
25	77	10.00	2.20
26	78.8	9.55	2.23
27	80.6	9.13	2.27
28	82.4	8.73	2.30
29	84.2	8.35	2.33
30	86	7.98	2.36
31	87.8	7.64	2.39
32	89.6	7.31	2.42
33	91.4	6.99	2.44
34	93.2	6.70	2.47
35	95	6.41	2.50
36	96.8	6.14	2.52
37	98.6	5.89	2.55
38	100.4	5.64	2.57
39	102.2	5.41	2.60
40	104	5.19	2.62
41	105.8	4.97	2.64
42	107.6	4.77	2.66
43	109.4	4.58	2.69
44	111.2	4.39	2.71
45	113	4.22	2.73
46	114.8	4.05	2.74
47	116.6	3.89	2.76
48	118.4	3.74	2.78
49	120.2	3.59	2.80
50	122	3.45	2.81
51	123.8	3.32	2.83
52	125.6	3.19	2.85
53	127.4	3.07	2.86
54	129.2	2.95	2.88
55	131	2.84	2.89
56	132.8	2.73	2.90
57	134.6	2.63	2.92
58	136.4	2.53	2.93
59	138.2	2.44	2.94
60	140	2.35	2.95
61	141.8	2.26	2.96
62	143.6	2.18	2.98
63	145.4	2.10	2.99

Temp. (°C)	Temp. (°F)	Resistance (KΩ)	Voltage (V)
64	147.2	2.02	3.00
65	149	1.95	3.01
66	150.8	1.88	3.02
67	152.6	1.81	3.03
68	154.4	1.75	3.04
69	156.2	1.68	3.04
70	158	1.63	3.05
71	159.8	1.57	3.06
72	161.6	1.51	3.07
73	163.4	1.46	3.08
74	165.2	1.41	3.08
75	167	1.36	3.09
76	168.8	1.31	3.10
77	170.6	1.27	3.10
78	172.4	1.23	3.11
79	174.2	1.19	3.12
80	176	1.15	3.12
81	177.8	1.11	3.13
82	179.6	1.07	3.13
83	181.4	1.03	3.14
84	183.2	1.00	3.14
85	185	0.97	3.15
86	186.8	0.94	3.15
87	188.6	0.91	3.16
88	190.4	0.88	3.16
89	192.2	0.85	3.17
90	194	0.82	3.17
91	195.8	0.80	3.17
92	197.6	0.77	3.18
93	199.4	0.75	3.18
94	201.2	0.72	3.18
95	203	0.70	3.19
96	204.8	0.68	3.19
97	206.6	0.66	3.19
98	208.4	0.64	3.20
99	210.2	0.62	3.20
100	212	0.60	3.20
101	213.8	0.59	3.21
102	215.6	0.57	3.21
103	217.4	0.55	3.21
104	219.2	0.54	3.21
105	221	0.52	3.22

Remarks:

Above table shows the average resistance corresponding to the temperature.
Resistance tolerance is $\pm 6\%$.

Temperature sensor B* (TF,TD)

Temp. (°C)	Temp. (°F)	Resistance (KΩ)	Voltage (V)
-20	-4	517.84	0.27
-19	-2.2	489.93	0.29
-18	-0.4	463.65	0.30
-17	1.4	438.89	0.32
-16	3.2	415.57	0.34
-15	5	393.59	0.35
-14	6.8	372.87	0.37
-13	8.6	353.34	0.39
-12	10.4	334.92	0.41
-11	12.2	317.55	0.43
-10	14	301.16	0.45
-9	15.8	285.70	0.47
-8	17.6	271.10	0.49
-7	19.4	257.33	0.51
-6	21.2	244.32	0.53
-5	23	232.03	0.56
-4	24.8	220.42	0.58
-3	26.6	209.45	0.60
-2	28.4	199.08	0.63
-1	30.2	189.27	0.66
0	32	180.00	0.68
1	33.8	171.23	0.71
2	35.6	162.93	0.74
3	37.4	155.07	0.77
4	39.2	147.63	0.80
5	41	140.59	0.83
6	42.8	133.92	0.86
7	44.6	127.60	0.89
8	46.4	121.60	0.92
9	48.2	115.93	0.95
10	50	110.54	0.98
11	51.8	105.43	1.02
12	53.6	100.59	1.05
13	55.4	95.99	1.08
14	57.2	91.62	1.12
15	59	87.48	1.15
16	60.8	83.54	1.19
17	62.6	79.80	1.22
18	64.4	76.25	1.26
19	66.2	72.87	1.29
20	68	69.66	1.33
21	69.8	66.61	1.37
22	71.6	63.70	1.40
23	73.4	60.94	1.44
24	75.2	58.31	1.47
25	77	55.81	1.51
26	78.8	53.42	1.54
27	80.6	51.15	1.58
28	82.4	48.99	1.62
29	84.2	46.93	1.65
30	86	44.97	1.69

Temp. (°C)	Temp. (°F)	Resistance (KΩ)	Voltage (V)
31	87.8	43.10	1.72
32	89.6	41.31	1.76
33	91.4	39.61	1.79
34	93.2	37.99	1.82
35	95	36.44	1.86
36	96.8	34.96	1.89
37	98.6	33.55	1.93
38	100.4	32.21	1.96
39	102.2	30.92	1.99
40	104	29.69	2.02
41	105.8	28.52	2.05
42	107.6	27.40	2.08
43	109.4	26.32	2.12
44	111.2	25.30	2.15
45	113	24.32	2.17
46	114.8	23.38	2.20
47	116.6	22.49	2.23
48	118.4	21.63	2.26
49	120.2	20.81	2.29
50	122	20.02	2.31
51	123.8	19.27	2.34
52	125.6	18.55	2.37
53	127.4	17.86	2.39
54	129.2	17.20	2.42
55	131	16.57	2.44
56	132.8	15.96	2.46
57	134.6	15.38	2.49
58	136.4	14.82	2.51
59	138.2	14.29	2.53
60	140	13.77	2.55
61	141.8	13.28	2.57
62	143.6	12.81	2.59
63	145.4	12.36	2.61
64	147.2	11.92	2.63
65	149	11.51	2.65
66	150.8	11.11	2.67
67	152.6	10.72	2.69
68	154.4	10.35	2.70
69	156.2	10.00	2.72
70	158	9.66	2.74
71	159.8	9.33	2.75
72	161.6	9.01	2.77
73	163.4	8.71	2.78
74	165.2	8.42	2.80
75	167	8.14	2.81
76	168.8	7.87	2.83
77	170.6	7.61	2.84
77	170.6	7.36	2.85
78	172.4	7.12	2.87
79	174.2	6.89	2.88
80	176	6.86	2.88

Temp. (°C)	Temp. (°F)	Resistance (KΩ)	Voltage (V)
81	177.8	6.67	2.89
82	179.6	6.46	2.90
83	181.4	6.25	2.91
84	183.2	6.05	2.92
85	185	5.86	2.93
86	186.8	5.68	2.94
87	188.6	5.50	2.95
88	190.4	5.33	2.96
89	192.2	5.16	2.97
90	194	5.00	2.98
91	195.8	4.85	2.99
92	197.6	4.70	3.00
93	199.4	4.55	3.01
94	201.2	4.42	3.02
95	203	4.28	3.02
96	204.8	4.15	3.03
97	206.6	4.03	3.04
98	208.4	3.91	3.05
99	210.2	3.79	3.05
100	212	3.68	3.06
101	213.8	3.57	3.07
102	215.6	3.46	3.07
103	217.4	3.36	3.08
104	219.2	3.26	3.09
105	221	3.17	3.09
106	222.8	3.09	3.10
107	224.6	3.00	3.10
108	226.4	2.92	3.11
109	228.2	2.84	3.11
110	230	2.76	3.12
111	231.8	2.68	3.12
112	233.6	2.60	3.13
113	235.4	2.53	3.13
114	237.2	2.46	3.14
115	239	2.39	3.14
116	240.8	2.33	3.14
117	242.6	2.26	3.15
118	244.4	2.20	3.15
119	246.2	2.14	3.16
120	248	2.08	3.16
121	249.8	2.03	3.16
122	251.6	1.97	3.17
123	253.4	1.92	3.17
124	255.2	1.87	3.17
125	257	1.82	3.18
126	258.8	1.77	3.18
127	260.6	1.72	3.18
128	262.4	1.68	3.19
129	264.2	1.63	3.19
130	266	1.59	3.19

Remarks:

Above table shows the average resistance corresponding to the temperature.

Resistance tolerance is $\pm 12\%$.

Low Pressure Sensor Voltage Characteristics C*

Low pressure (MPa)	Low pressure (psig)	Resistance (KΩ)	Output voltage(V)
0.10	14.5	49.51	0.70
0.11	16	47.91	0.72
0.12	17.4	46.40	0.74
0.13	18.9	44.97	0.76
0.14	20.3	43.61	0.78
0.15	21.8	42.32	0.80
0.16	23.2	41.09	0.82
0.17	24.7	39.92	0.84
0.18	26.1	38.80	0.86
0.19	27.6	37.74	0.88
0.21	30.5	35.74	0.92
0.22	31.9	34.81	0.94
0.23	33.4	33.92	0.96
0.24	34.8	33.06	0.98
0.26	37.7	31.45	1.02
0.27	39.2	30.69	1.04
0.29	42.1	29.25	1.08
0.30	43.5	28.58	1.10
0.32	46.4	27.29	1.14
0.33	47.9	26.68	1.16
0.35	50.8	25.52	1.20
0.37	53.7	24.44	1.24
0.38	55.1	23.92	1.26
0.40	58	22.94	1.30
0.42	60.9	22.01	1.34
0.44	63.8	21.14	1.38
0.46	66.7	20.32	1.42
0.48	69.6	19.54	1.46
0.50	72.5	18.81	1.50
0.52	75.4	18.11	1.54
0.54	78.3	17.45	1.58
0.56	81.2	16.82	1.62
0.58	84.1	16.22	1.66
0.61	88.5	15.37	1.72
0.63	91.4	14.84	1.76
0.65	94.3	14.33	1.80

Low pressure (MPa)	Low pressure (psig)	Resistance (KΩ)	Output voltage(V)
0.68	98.6	13.61	1.86
0.70	102	13.15	1.90
0.73	106	12.50	1.96
0.76	110	11.89	2.02
0.78	113	11.50	2.06
0.81	117	10.95	2.12
0.84	122	10.43	2.18
0.87	126	9.93	2.24
0.90	131	9.46	2.30
0.93	135	9.02	2.36
0.96	139	8.59	2.42
0.99	144	8.19	2.48
1.02	148	7.81	2.54
1.06	154	7.32	2.62
1.09	158	6.98	2.68
1.13	164	6.54	2.76
1.16	168	6.23	2.82
1.20	174	5.84	2.90
1.24	180	5.46	2.98
1.27	184	5.20	3.04
1.31	190	4.86	3.12
1.35	196	4.53	3.20
1.39	202	4.23	3.28
1.43	207	3.93	3.36
1.48	215	3.59	3.46
1.52	220	3.32	3.54
1.56	226	3.07	3.62
1.61	233	2.77	3.72
1.65	239	2.55	3.80
1.70	247	2.27	3.90
1.75	254	2.02	4.00
1.80	261	1.77	4.10
1.85	268	1.54	4.20
1.90	276	1.31	4.30
1.95	283	1.10	4.40
2.00	290	0.90	4.50

High Pressure Sensor Voltage Characteristics D*

High pressure (MPa)	High pressure (psig)	Resistance (KΩ)	Output voltage(V)
0.1	14.5	60.60	0.59
0.2	29	51.74	0.67
0.3	43.5	44.90	0.76
0.4	58	39.47	0.85
0.5	72.5	35.05	0.93
0.6	87	31.38	1.02
0.7	101.5	28.29	1.11
0.8	116	25.64	1.20
0.9	130.5	23.36	1.28
1.0	145	21.36	1.37
1.1	159.5	19.61	1.46
1.2	174	18.05	1.54
1.3	188.5	16.66	1.63
1.4	203	15.41	1.72
1.5	217.5	14.27	1.80
1.6	232	13.25	1.89
1.7	246.5	12.31	1.98
1.8	261	11.45	2.07
1.9	275.5	10.66	2.15
2.0	290	9.94	2.24
2.1	304.5	9.26	2.33
2.2	319	8.64	2.41
2.3	333.5	8.06	2.50
2.4	348	7.52	2.59
2.5	362.5	7.01	2.67
2.6	377	6.54	2.76
2.7	391.5	6.09	2.85
2.8	406	5.67	2.93
2.9	420.5	5.28	3.02
3.0	435	4.90	3.11

High pressure (MPa)	High pressure (psig)	Resistance (KΩ)	Output voltage(V)
3.1	449.5	4.55	3.20
3.2	464	4.22	3.28
3.3	478.5	3.90	3.37
3.4	493	3.60	3.46
3.5	507.5	3.31	3.54
3.6	522	3.04	3.63
3.7	536.5	2.78	3.72
3.8	551	2.53	3.80
3.9	565.5	2.30	3.89
4.0	580	2.07	3.98
4.1	594.5	1.85	4.07
4.2	609	1.65	4.15
4.3	623.5	1.45	4.24
4.4	638	1.26	4.33
4.5	652.5	1.07	4.41
4.6	667	0.90	4.50
4.7	681.5	0.73	4.59
4.8	696	0.56	4.67
4.9	710.5	0.40	4.76

5.2 Wiring Diagram

EOADA18H-2436

231311491
AUG 2018 V1.5

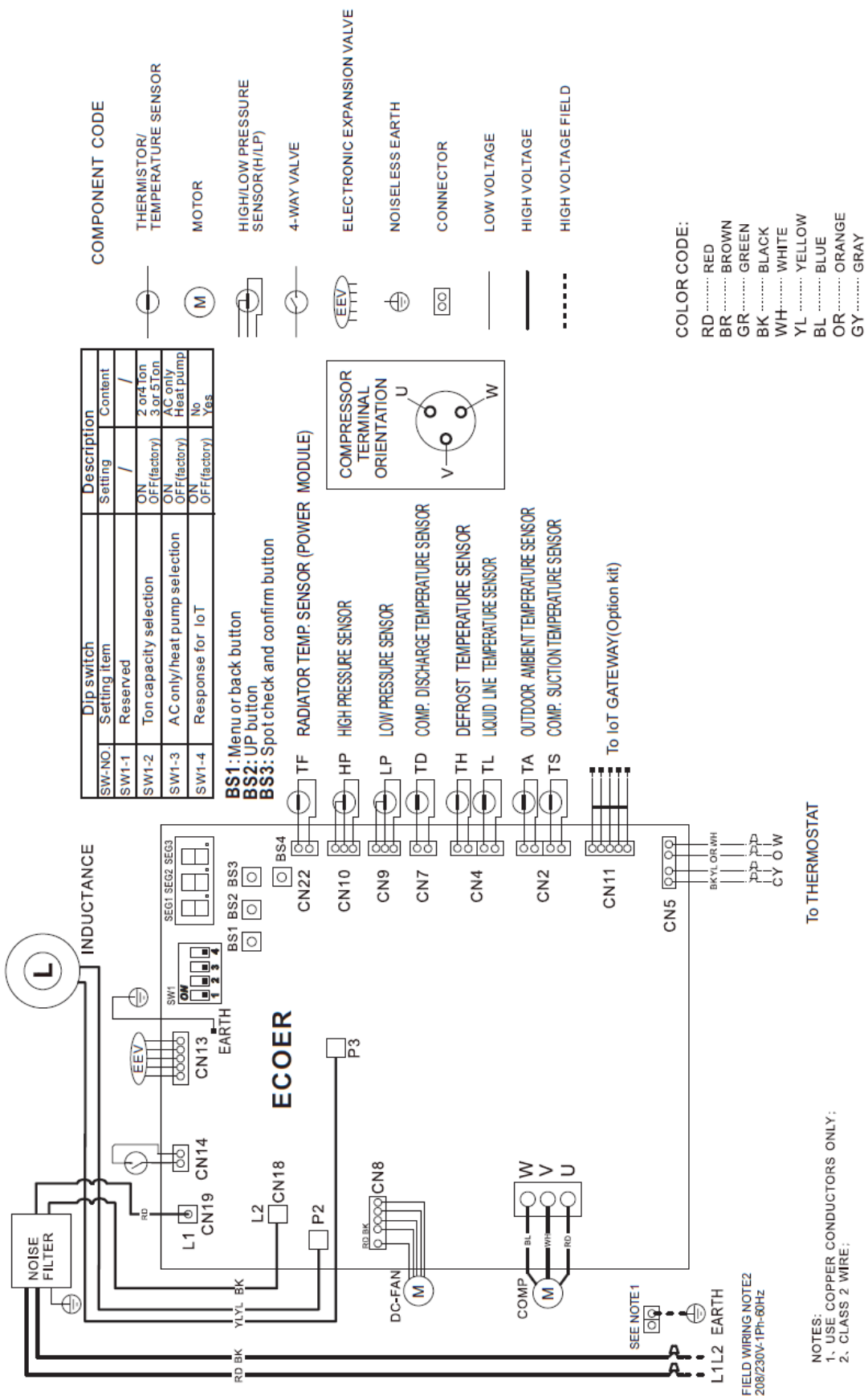

COMPONENT CODE

	THERMISTOR/TEMPERATURE SENSOR
	MOTOR
	HIGH/LOW PRESSURE SENSOR(H/LP)
	4-WAY VALVE
	ELECTRONIC EXPANSION VALVE
	NOISELESS EARTH
	CONNECTOR
	LOW VOLTAGE
	HIGH VOLTAGE
	HIGH VOLTAGE FIELD

SW-NO.	Setting Item	Description	
		Setting	Content
SW1-1	Reserved	/	/
SW1-2	Ton capacity selection	ON OFF(factory)	2 or 4 Ton 3 or 5 Ton
SW1-3	AC only/heat pump selection	ON OFF(factory)	AC only Heat pump
SW1-4	Response for IoT	ON OFF(factory)	No Yes

BS1: Menu or back button
BS2: UP button
BS3: Spot check and confirm button

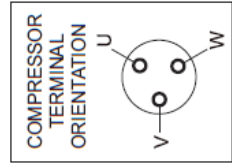

COLOR CODE:

RD	RED
BR	BROWN
GR	GREEN
BK	BLACK
WH	WHITE
YL	YELLOW
BL	BLUE
OR	ORANGE
GY	GRAY

To THERMOSTAT

To IoT GATEWAY (Option kit)

NOTES:
1. USE COPPER CONDUCTORS ONLY;
2. CLASS 2 WIRE;

FIELD WIRING NOTEZ
208/230V-1Ph-60Hz

High Voltage: Disconnect all power before servicing or installing this unit. Multiple power sources may be present. Failure to do so may cause property damage, personal injury, or death. Wiring is subject to change. Always refer to the wiring diagram or the unit for the most up-to-date wiring.

WARNING

EODA18H-4860

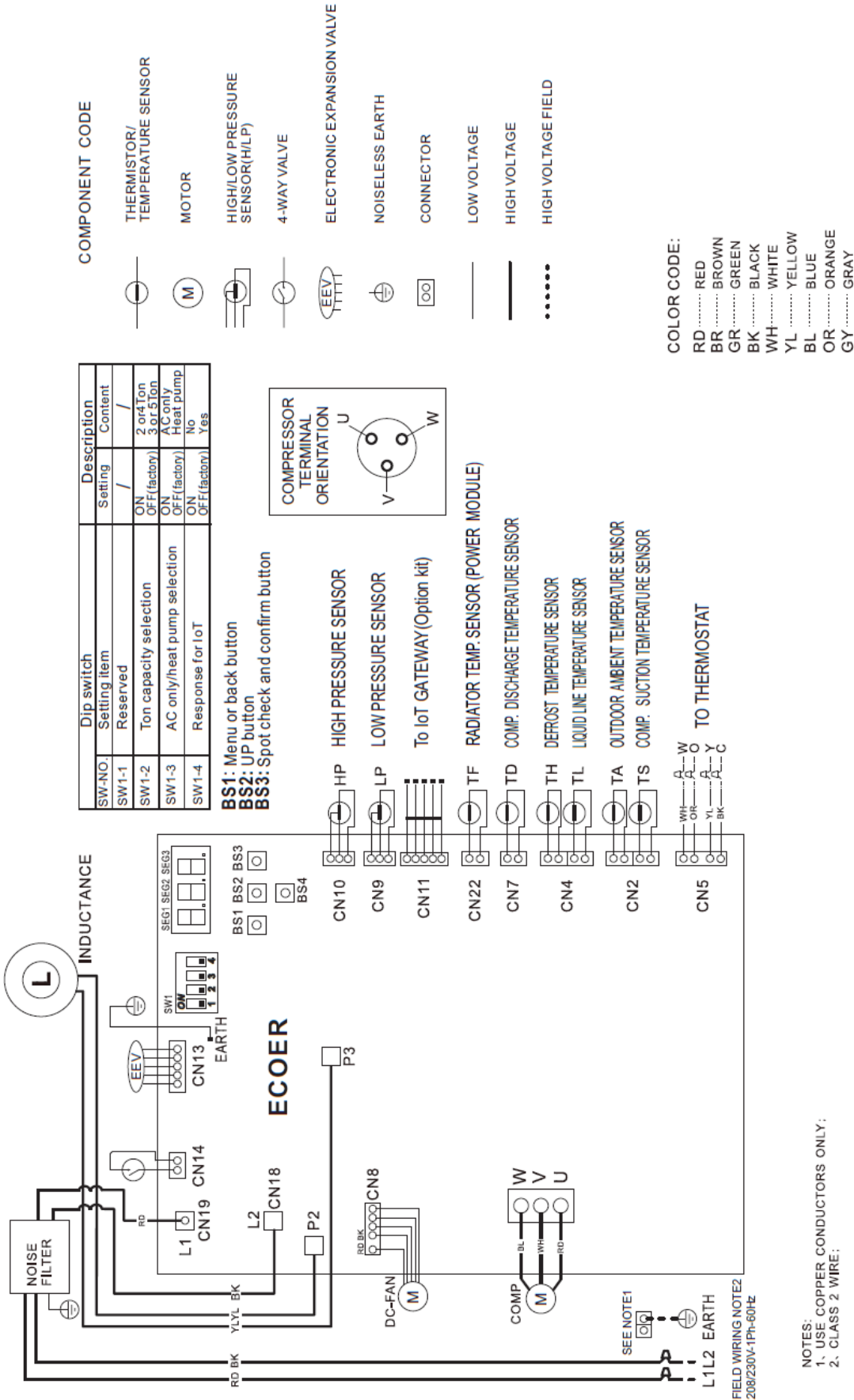

231311490
AUG 2018 V1.5

High Voltage: Disconnect all power before servicing or installing this unit. Multiple power sources may be present. Failure to do so may cause property damage, personal injury, or death. Wiring is subject to change. Always refer to the wiring diagram or the unit for the most up-to-date wiring.

WARNING

- NOTES:
1. USE COPPER CONDUCTORS ONLY;
 2. CLASS 2 WIRE;

©2017-2019 ECOER INC.

3900 Jermantown Rd., Suite 150, Fairfax, VA 22030

Tel: 703-348-2538

www.ecoer.com