



Installation Manual

Inverter Split Heat Pump
Up to 20 SEER
2-3-4-5Ton Capacity

Contents

1. Safety-----	2
2. Unit Location Considerations-----	4
3. Position the Unit-----	6
4. Refrigerant Line Considerations-----	7
5. Refrigerant Line Routing-----	9
6. Refrigerant Line Brazing-----	10
7. System Leak Check-----	11
8. Evacuation-----	11
9. Service Valves-----	12
10. Electrical - Low Voltage-----	13
11. Electrical - High Voltage-----	14
12. Start-up-----	15
13. System Charge Adjustment-----	16
14. System Operation-----	21
15. Trouble Shooting-----	28
16. Wiring Diagram-----	30

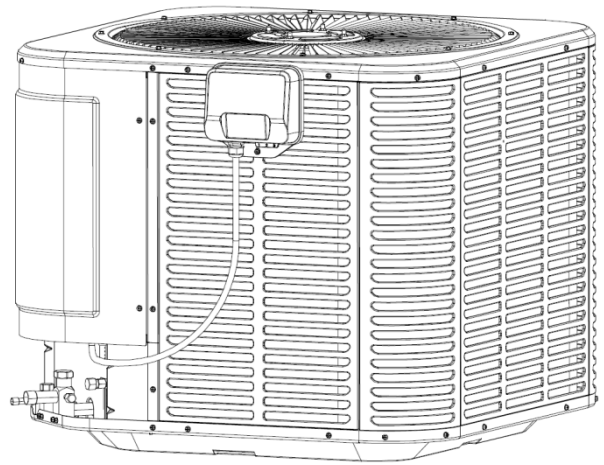

NOTE: Appearance of unit may vary.

IoT gateway does not ship with outdoor unit.

Installation must be performed in accordance with the requirements of NEC and CEC by authorized personnel only.

All phases of this installation must comply with National, State and Local Codes.

IMPORTANT

This document is customer’s property and is to remain with this unit. Please return it to customer with service information upon completion of work.

These instructions do not cover all variations in systems or provide for every possible contingency to be met in connection with the installation. Should further information be desired or should particular problems arise which are not covered sufficiently for the purchaser’s purposes, the matter should be referred to your installing dealer or local distributor.



1. Safety

Read the following safety instructions before installing the unit or doing servicing work.

 **WARNING** may cause personal death or serious injury.

 **CAUTION** may lead to injury or structural damage under some conditions.



WARNING

HAZARDOUS VOLTAGE

Failure to follow this warning could result in property damage, severe personal injury, or death.

Disconnect all electric power, including remote disconnections before servicing. Follow proper lockout/tagout procedures to ensure the power cannot be inadvertently energized.

REFRIGERANT OIL

Any attempt to repair central air conditioner and heat pump products may result in property damage, severe personal injury, or death.

These units use R-410A refrigerant which operates at 50~70% higher pressures than R-22. Use only R-410A approved service equipment. Refrigerant cylinders are painted a “Rose” color to indicate the type of refrigerant and may contain a “dip” tube to allow for charging of liquid refrigerant into the system.

All R-410A systems with variable speed compressors use a **PVE oil** that readily absorbs moisture from the atmosphere. To limit this “hygroscopic” action, the system should remain sealed whenever possible. If a system has been open to the atmosphere for more than 4 hours, the compressor oil must be replaced. Never break a vacuum with air and always change the driers when opening the system for component replacement.

PVE oil is not just a lubricant but also a great solvent! It will quickly move any contaminants from the old line sets and plug up components like TXV, strainer and service valves. When replacing R-22 system with a new R-410A system, use flush (e.g. Rx11) to remove the old mineral oil, sludge, moisture, acid and other contaminants out of the system.

SERVICE VALVES

Failure to follow this warning will result in abrupt release of system charge and may result in personal injury and/or property damage.

Extreme caution should be exercised when opening the liquid service valve. Turn valve stem counterclockwise only until the stem contacts the rolled edge. No torque is required.

BRAZING REQUIRED

Failure to inspect refrigerant lines or use proper service tools may result in equipment damage or personal injury. If using existing refrigerant lines, make sure that all joints are brazed, not soldered.

HIGH CURRENT LEAKAGE

Failure to follow this warning could result in property damage, severe personal injury, or death.

Grounding is essential before connecting electrical supply.



CAUTION

AUTHORIZED PERSONNEL ONLY

This information is intended for use by individuals possessing adequate backgrounds of electrical and mechanical experience. Any attempt to repair central air conditioner or heat pump products may result in personal injury and/or property damage.

INDOOR UNIT REQUIREMENT

The indoor units must be equipped with **adjustable non-bleed TXV for R-410A heat pump**. The model of TXV can be changed according to the system capacity.

No micro channel coil shall be used for heat pump.

Micro channel coils are suitable for cooling only system.

HOT SURFACE

May cause minor to severe burning.

Failure to follow this caution could result in property damage or personal injury.

Do not touch top of compressor.

GROUNDING REQUIRED

Failure to inspect or use proper service tools may result in equipment damage or personal injury. Reconnect all grounding devices. All parts of this product that are capable of conducting electrical current are grounded. If grounding wires, screws, straps, clips, nuts, or washers used to complete a path to ground are removed for service, it must be returned to their original position and properly fastened.

CONTAINS REFRIGERANT

Failure to follow proper procedures can result in personal illness or injury or severe equipment damage. System contains oil and refrigerant under high pressure. Recover refrigerant to relieve pressure before opening the system.

2. Unit Location Considerations

2.1 Inspect Units

Units are packaged for shipment to avoid damage during normal transit and handling. It is the receiving party’s responsibility to inspect the equipment upon arrival. Any obvious damage to the carton box should be reported on the bill of lading and a claim should be filed with the transportation company, and the factory should be noticed.

All units should be stored in the factory shipping carton with internal packaging in a dry place until installation. Carefully remove the packaging and inspect for hidden damage. Any hidden damage should be recorded and the factory should be notified. The gauge port can be used to check the refrigerant charge has been retained during shipment.

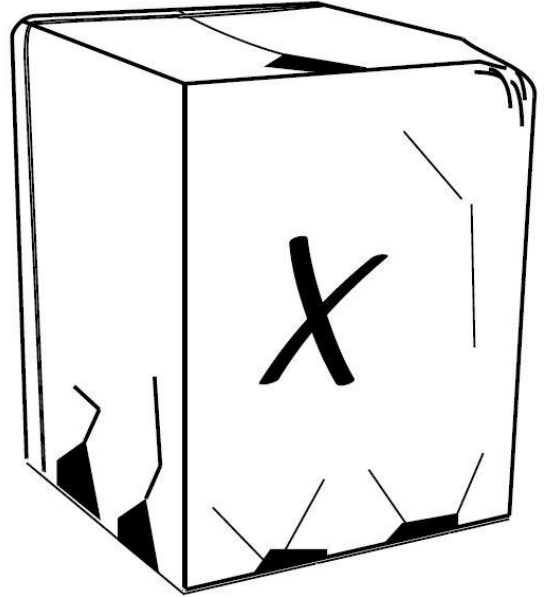

Figure 2-1 Check damage

2.2 Unit Dimensions

Two models with the same chassis are suit for most of residential air conditioner and heat pump applications, only have height difference for external dimensions.

Table 2-1 Outdoor unit dimensions

Unit Dimensions	
Model	H x W x D (Inches)
2436	24-15/16 x 29-1/8 x 29-1/8
4860	33-3/16 x 29-1/8 x 29-1/8

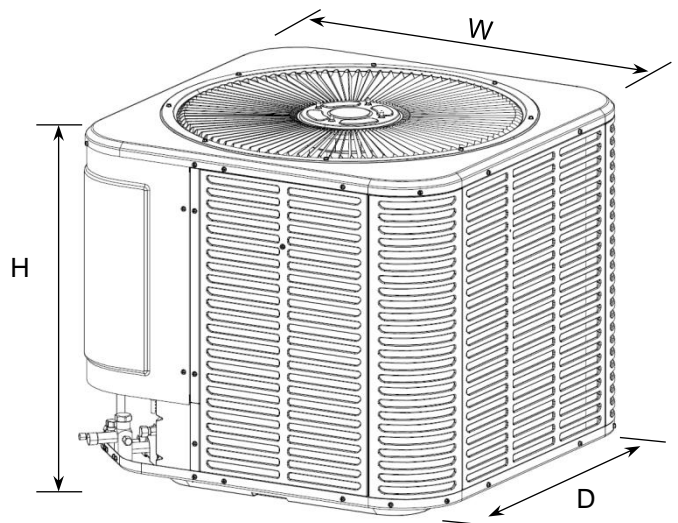

Figure 2-2 External dimensions

2.3 Location Restrictions

Installation Clearance Requirement

Ensure the top discharge area is unrestricted for at least **60 inches** above the unit.

Do not locate outdoor unit near bedrooms since normal operational sounds may be annoying. Position unit to allow adequate space for unobstructed airflow, wiring, refrigerant lines, and serviceability.

Allow a minimum of 20 in. clearance on one side of access panel to a wall and a minimum of 24 in. on the adjacent side of access panel. **Maintain a distance of 24 in. between units.**

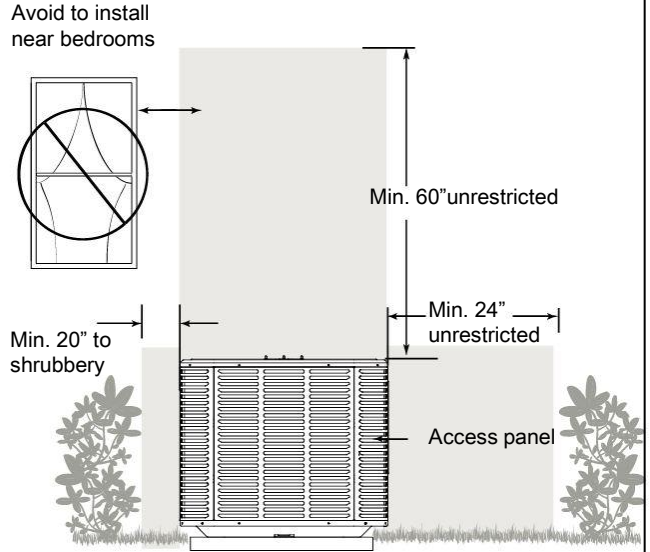

Figure 2-3 Clearance requirement

Position unit so water, snow, or ice from roof or overhang cannot fall directly on unit.

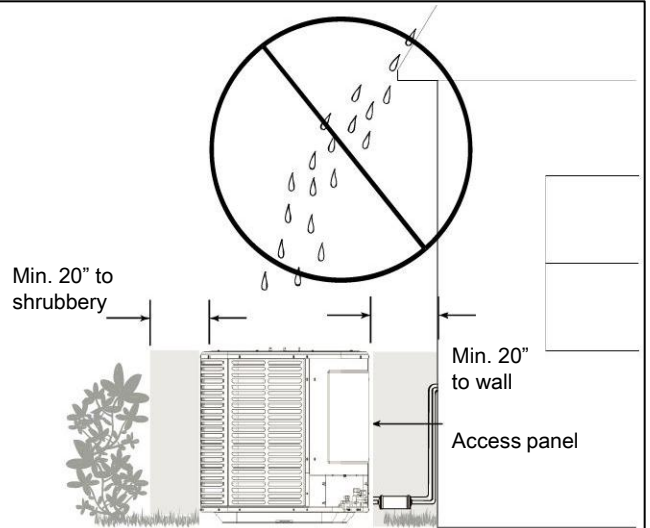

Figure 2-4 Unit location choose

Cold Climate Considerations

Precautions must be taken for units being installed in areas where snow accumulation and prolonged below-freezing temperatures occur.

Depending on local weather, units should be elevated **at least 3~12 inches above the pad or rooftop**. This additional height will allow drainage of snow and ice melted during defrost cycle to flow out smoothly prior to its refreezing.

A snow drift barrier should be installed around the unit to prevent a build-up of snow on the unit sides.

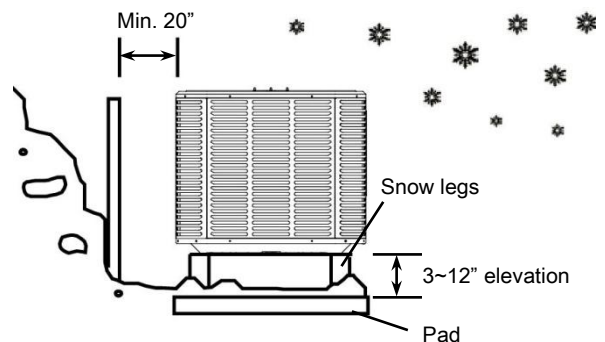

Figure 2-5 Consideration to prevent refreezing

3. Position the Unit

When mounting the unit on a roof, be sure the roof will support the unit's weight obtained from nameplate. Properly selected isolation is recommended to prevent sound or vibration transmission to the building structure.

When installing the unit on a support pad, such as a concrete slab, consider the following:

- The pad must be 1~2" larger than the unit on all sides.
- The pad must be separated from any structure.
- The pad must be level.
- The pad must be high enough above grade to allow for drainage.
- The pad location must comply with National, State and Local codes.

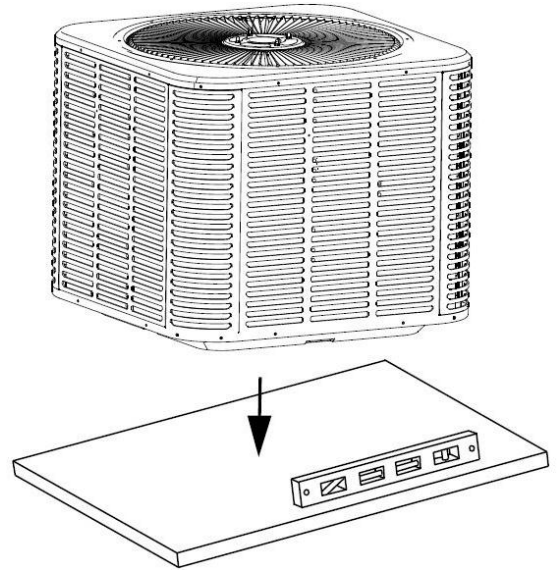

Figure 3-1 Position the unit on pad

IMPORTANT NOTE:

These instructions are intended to provide a method to tie-down unit to cement slab as a securing procedure for high wind areas. Check local codes for tie-down methods and protocols.

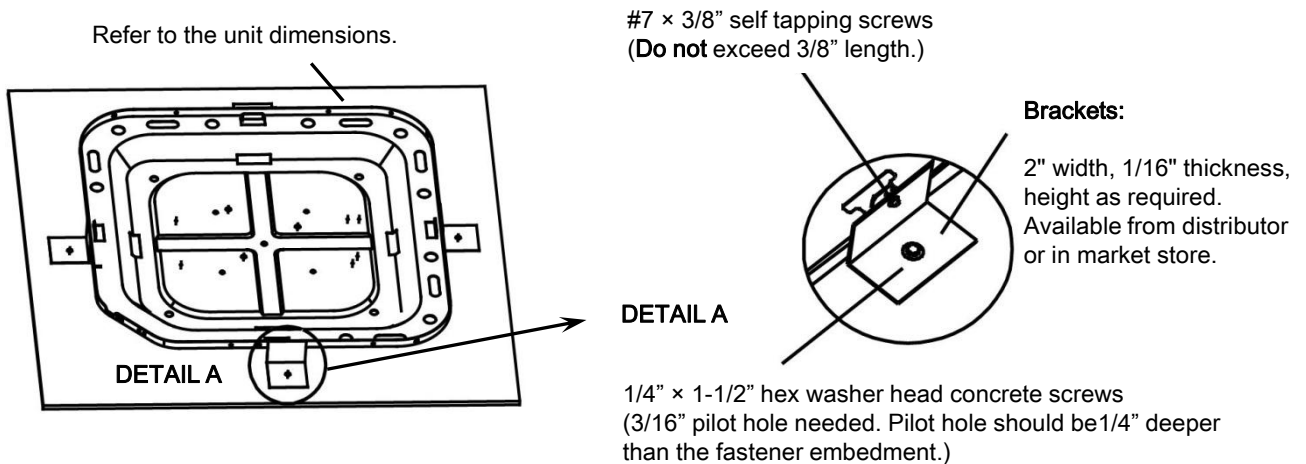

Figure 3-2 Fasten the outdoor unit

4. Refrigerant Line Considerations

4.1 Refrigerant Line and Service Valve Connection Sizes

Table 4-1 Line sizes

Model	Suction line	Liquid line	Suction line connection	Liquid line connection
2436	3/4	3/8	3/4	3/8
4860	7/8		7/8	

4.2 Refrigerant Line Limits

Use only the line sizes indicated in Table 4-1 and determine required line length.

• Maximum line length = 100 feet.

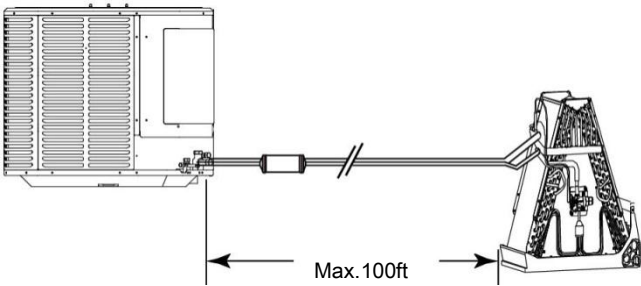

Max.100ft

Figure 4-1 Line length limit

• Maximum elevation difference = 50 feet.

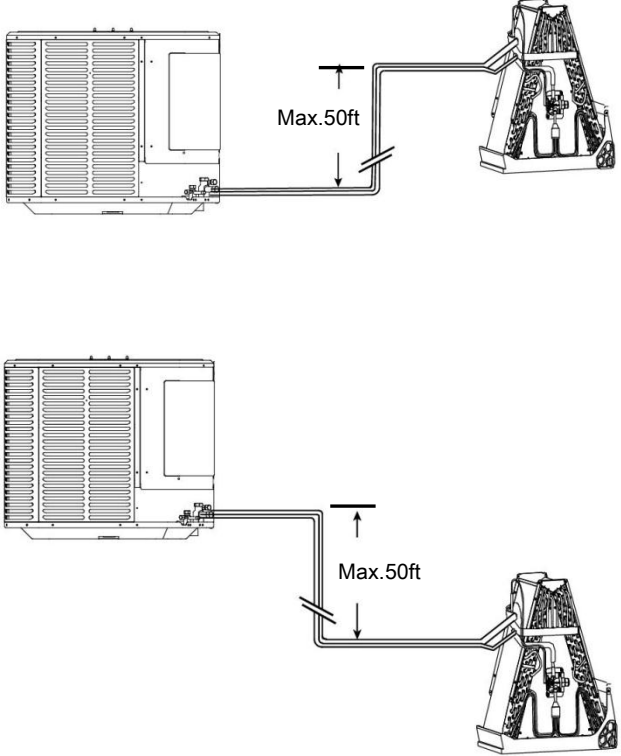

Max.50ft

Max.50ft

Figure 4-2 Elevation difference limit

4.3 Refrigerant Line Insulation

The suction line must always be insulated.

DO NOT allow the suction line and liquid line to come in direct (metal to metal) contact.

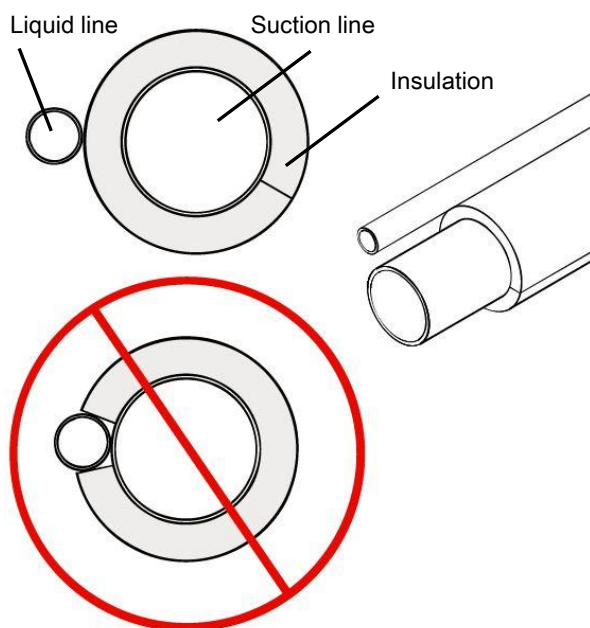

Figure 4-3 Line insulation

4.4 Reuse Existing Refrigerant Lines

⚠ CAUTION

If using existing refrigerant lines, make sure that all joints are brazed, not soldered.

For retrofit applications where the existing refrigerant lines will be used, the following precautions should be taken:

- Ensure that the refrigerant lines are the correct size according to Table 4-1. It's not recommended to use suction line bigger than standard size, in which will result poor oil return for inverter compressor.
- Ensure that the refrigerant lines are **free of leaks, acid and mineral oil**. When replacing R-22 system with a new R-410A system, be sure the existing lines can endure R-410A pressure which is 50~70% higher than R-22 system. Use flush (e.g. Rx11) to remove the old mineral oil, sludge, moisture, acid and other contaminants out of the line set.

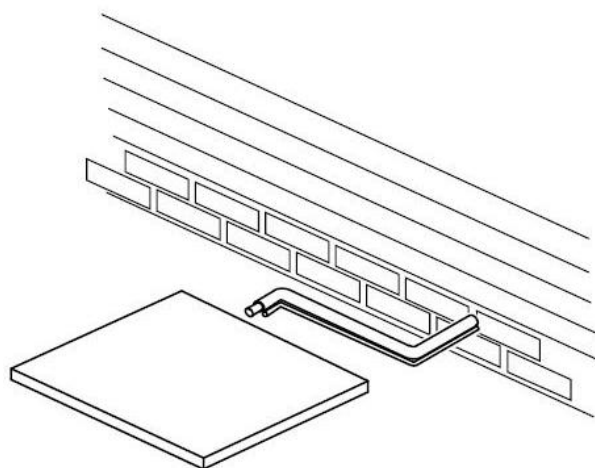

Figure 4-4 Use existing refrigerant lines

IMPORTANT:

The manufacturer recommends installing only approved matched indoor and outdoor systems. All of the manufacturer's split systems are AHRI rated with TXV indoor units. Some of the benefits of installing approved matched indoor and outdoor split systems are maximum efficiency, optimum performance and the best overall system reliability.

5. Refrigerant Line Routing

Comply with National, State, and Local Codes when isolating line sets from joists, rafters, walls, or other structural elements. Take precautions to prevent noise within the building structure due to vibration transmission from the refrigerant lines. For Example:

- Use isolation type hangers when the refrigerant lines have to be fastened to floor joists or other framing.
- Isolation hangers should also be used when refrigerant lines traverse stud spaces or enclosed ceilings.
- Where the refrigerant lines pass through a wall or sill, it should be insulated and isolated.
- Isolate the lines from all ductwork.
- Minimize the number of 90° turns.

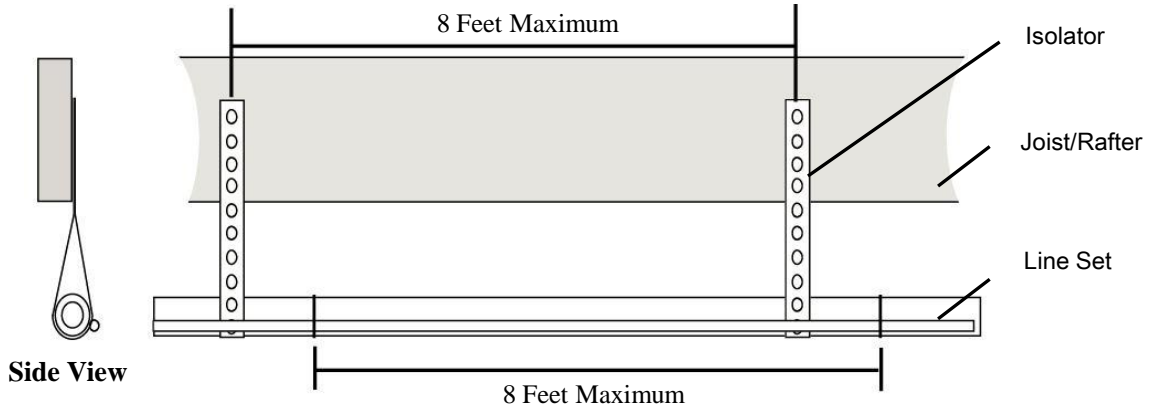

Secure suction line from joists using isolators every 8 ft. Secure liquid line directly to insulated suction line using tape, wire, or other appropriate method every 8 ft.

Figure 5-1 Isolation from Joist/Rafter

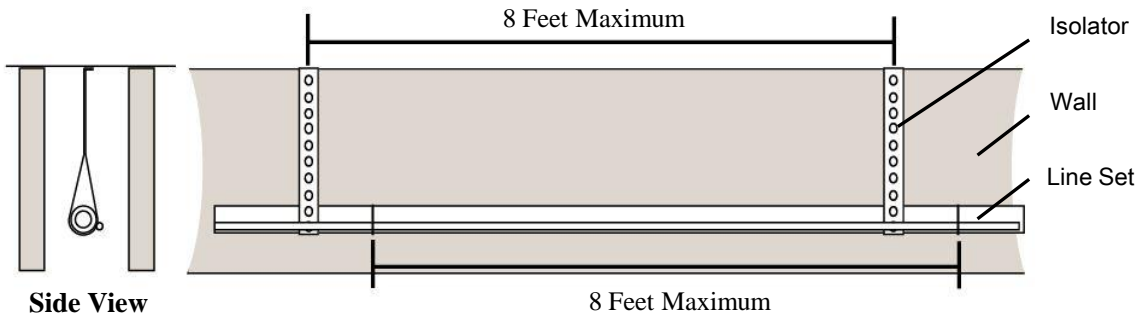

Secure suction line using isolators every 8 ft. Secure liquid line directly to insulated suction line using tape, wire, or other appropriate method every 8 ft.

Figure 5-2 Isolation in wall spaces

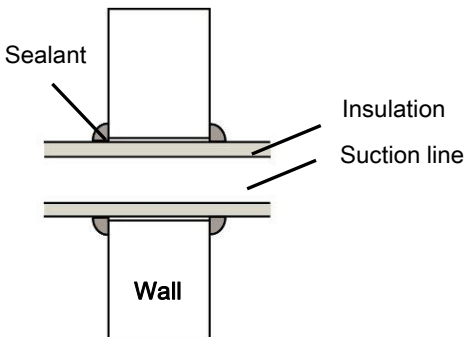

Figure 5-3 Isolation through wall

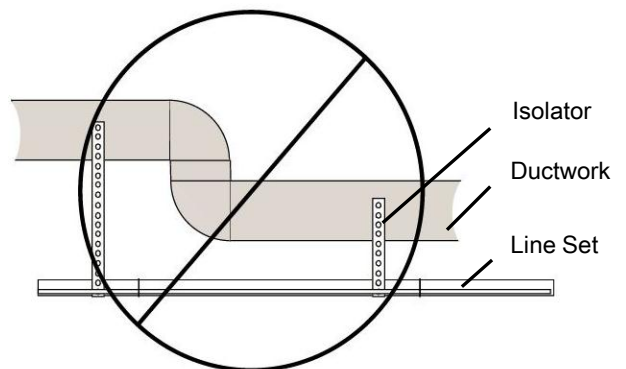

Figure 5-4 DO NOT hang line sets from ductwork

6. Refrigerant Line Brazing

Refer to below figures marked with digital number for line brazing procedures. Every figure is corresponding to the following illustrations.

1. Remove caps or plugs. Use a tool to deburr the line ends. Clean both internal and external surfaces of the tubing using an emery cloth.
2. Remove the pressure tap cap from both service valves.
3. Purge the refrigerant lines and indoor coil with **dry nitrogen** from gas service valve.
4. Wrap a wet rag around the service valve body to avoid heat damage and continue the dry nitrogen purge. Braze the refrigerant lines to the service valves. Install a **bidirectional filter drier** in liquid side to protect the heat pump system. Do not remove the wet rag until all brazing is completed.
5. Put the pressure tap caps back after the service valves cooled down.

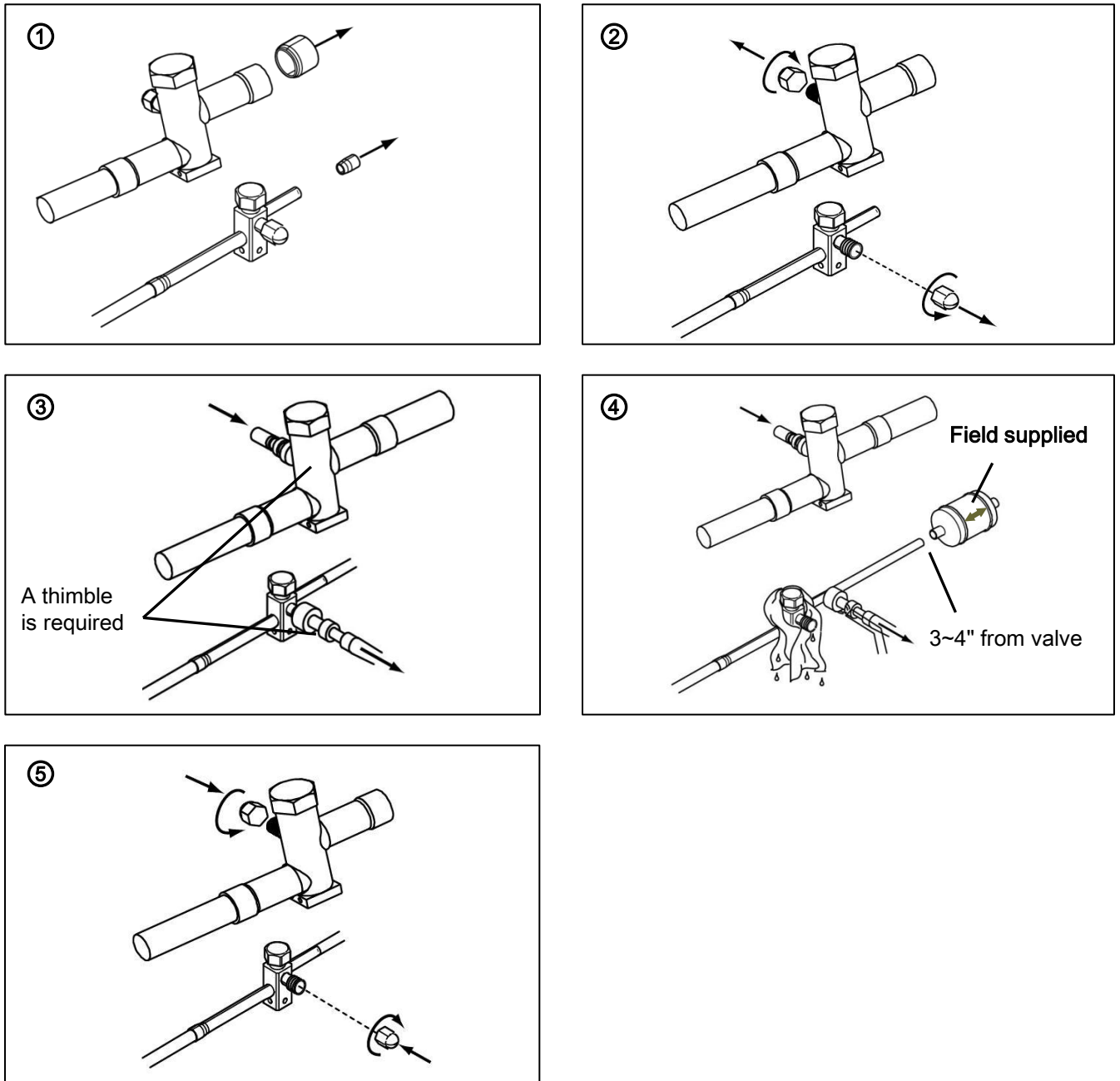

Figure 6-1 Refrigerant line brazing work

7. System Leak Check

Leak check is required for the brazed line connections.

1. Pressurize the brazed refrigerant lines and indoor coil to at least 150 PSIG using dry nitrogen.
2. Check for leaks by using a soapy solution or bubbles at each brazed location.

150PSIG

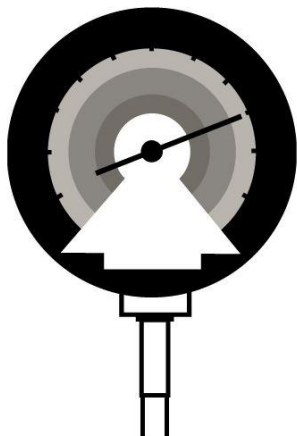

Figure 7-1 Charge dry nitrogen to the system

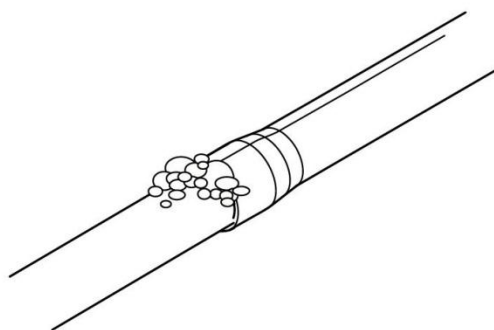

Figure 7-2 Leak check

8. Evacuation

Do not open the service valves until the leak check and evacuation are complete.

1. Evacuate until the micron gauge reads no higher than 350 microns, then close the valve to the vacuum pump.
2. Evacuation is complete if the micron gauge does not rise above 500 microns in one minute.

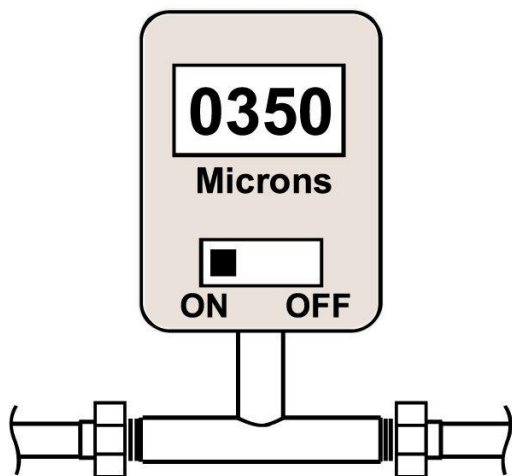

Figure 8-1 Evacuation the refrigerant system

9. Service Valves

Leak check and evacuation must be completed before opening the service valves.

The Suction Service valve must be opened BEFORE opening the Liquid Service Valve!

1. Remove service valve cap.
2. Fully insert hex wrench into the stem and counterclockwise until valve stem just touches the rolled edge (approximately five turns.)
3. Replace and tighten the valve stem cap to prevent leaks. Additional 1/6 turn may be required.

Repeat 1 to 3 for Liquid Service Valve.

WARNING

Extreme caution should be exercised when opening the Liquid Service Valve. Turn counterclockwise until the valve stem just touches the rolled edge. No torque is required.

Failure to follow this will result in abrupt release of system charge and may lead to personal injury and /or property damage.

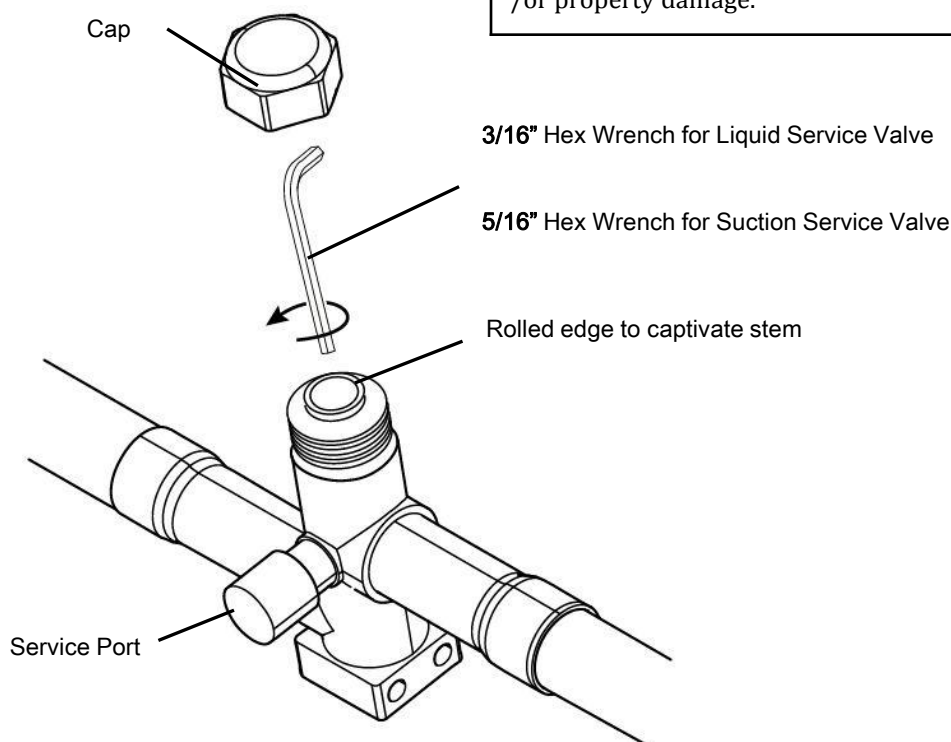

Figure 9-1 Open the service valves

10. Electrical – Low Voltage

10.1 Low voltage wire requirement

Define the maximum total length of low voltage wiring from outdoor unit to indoor unit and thermostat.

Field installed electrical conduit is required at the low voltage wire entry point. Animals like frogs, snakes, spiders and others may climb into the control box resulting in the PCB damage. **Manufacturer reserves the rights to reject warranty claim on PCB if not comply.**

Table 10-1 Low voltage control wiring requirement

CONTROL WIRING	
Wire Size	Max. Wire Length
18 AWG	150Ft
16 AWG	225Ft

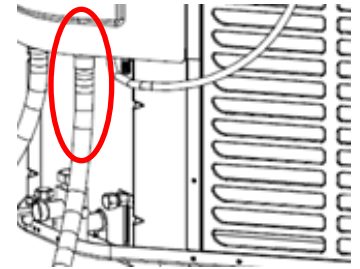

Figure 10-1 Sealing requirement

10.2 Low voltage hook-up diagrams

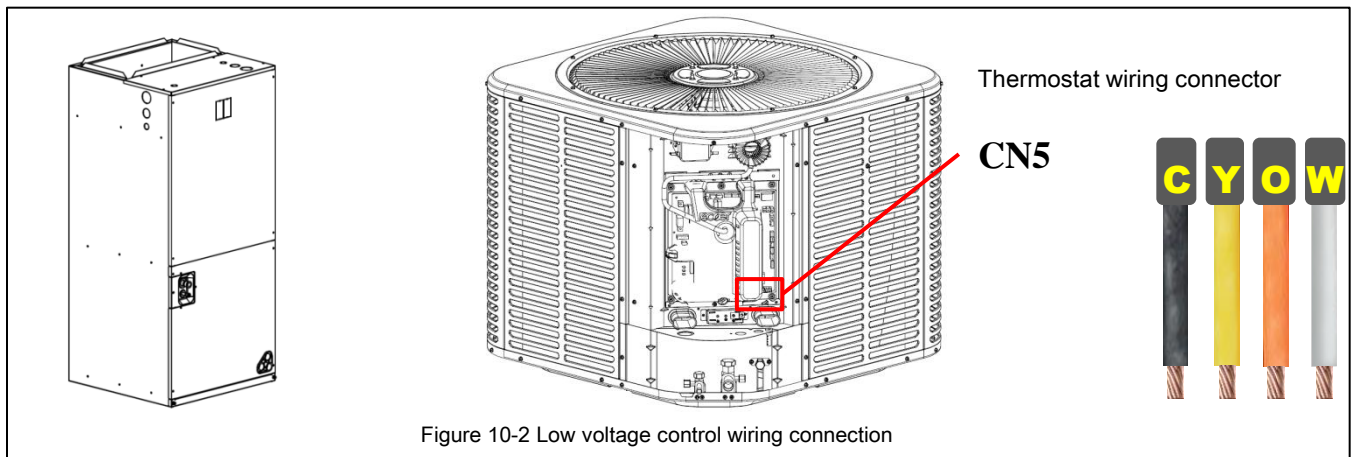

Figure 10-2 Low voltage control wiring connection

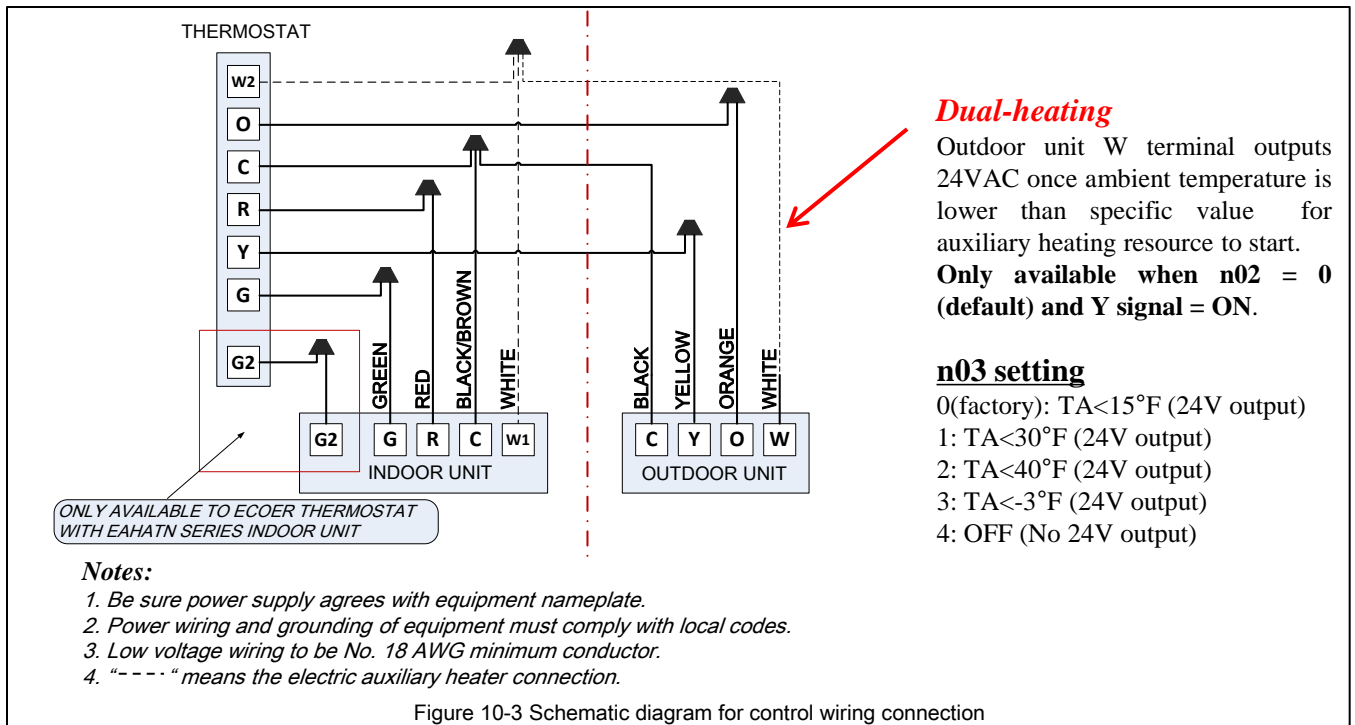



Figure 10-3 Schematic diagram for control wiring connection

11. Electrical – High Voltage

11.1 High voltage power supply

WARNING

During installation, testing, servicing, and trouble shooting of this product, it may be necessary to work with live electrical components. Failure to follow all electrical safety precautions when exposed to live electrical components could result in death or serious injury.

The high voltage power supply must agree with the equipment nameplate. Power wiring must comply with National, State and Local codes.

Follow instructions on unit wiring diagram located on the inside of the control box cover.

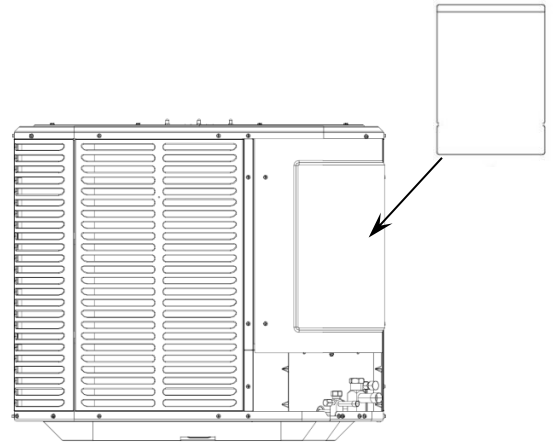

Figure 11-1 Read the Warning Label

Power Supply			
Model	Voltage	MCA	Breaker
2436	208/230V-1Ph-60Hz	24.4A	40A
4860	208/230V-1Ph-60Hz	32.5A	50A

11.2 High voltage disconnect switch

Install a separated disconnect switch at the outdoor unit. Field provided **flexible electrical conduit** must be used for high voltage wiring.

In order to get full warranty coverage on the compressor, it's mandatory to install a **surge protector** to prevent the unit from damaging caused by abnormal electrical spikes.

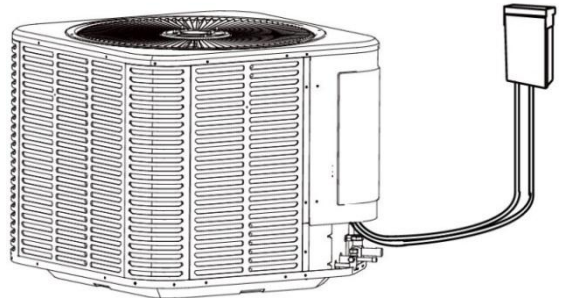

Figure 11-2 Install an independent switch

11.3 High voltage ground

Ground the outdoor unit according to National, State, and Local code requirements.

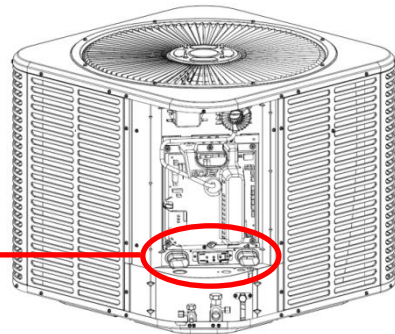
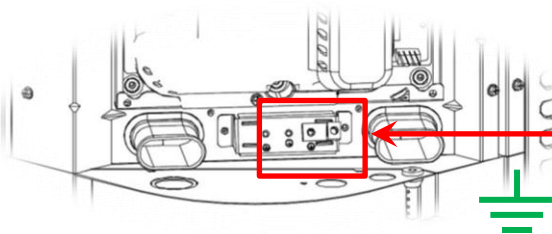

Figure 11-3 Unit grounding

12. Start-up

Refer to IoT Installation and Warranty Guide by ESS Pro App, connect the IoT gateway before start-up. At the same time, ensure chapters 5~11 have been completed.

1. Set the thermostat to OFF.



2. Turn on disconnect switch to apply power to the indoor and outdoor units.

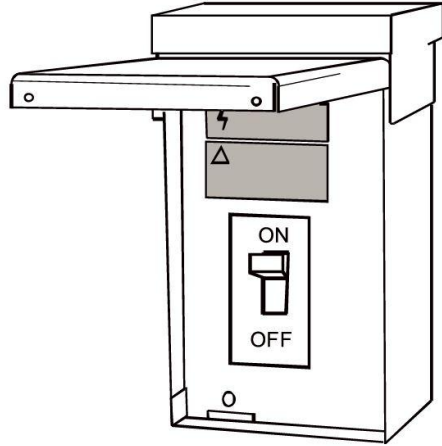

3. Wait one hour before starting the unit if the outdoor ambient temperature < 59 F.



4. Set the thermostat to ON.



Note:

It may take up to **45 minutes** in the first time for heating operation to exit start-up control. This is normal function to preheat lubricants in the bottom of compressor.

13. System Charge Adjustment

13.1 Weigh-in Method

Weigh-in method can be used for the initial installation, or anytime a system charge needs to be replaced.

Weigh-in method can also be used when power is not available on job site or ambient temperature is improper to use refrigerant coefficient and sub-cooling charge method.

When use weigh-in method in heating mode, be sure the compressor discharge superheat (DSH=TD-SC-TL-1.8 F) meets the target value. Basically, the liquid line sub-cooling (SC) shall not exceed 30 F.

Use the **gauge port** to charge the system in heating mode, query live data by BS3 button to calculate DSH or check SC/DSH from ESS Pro App.



25~50°F
DSH

Table 13-1 Charge amount table

A	B	C		D
Model	Factory charge	Indoor air handler	Charge amount for indoor coil (oz)	Charge multiplier for interconnecting refrigerant tube length *2
2436	The data on nameplate	24K	0	0.6 oz/ft
		36K	14 *1	
36K		0		
48K		0		
60K		14 *1		

1. Invalid for system with electric heaters or other third-party heaters whose capacity is 1.2 times of heat pump nominal heating capacity.

For example: 3 Ton system equips a 15KW indoor electric heater.

$$15 / (3 * 3.516) = 1.42 > 1.2$$

Note: 1Ton=3.516KW

2. Only take line length over 25ft into consideration.

Every condensing unit pre-charged up to 25 feet of standard size interconnecting liquid line.

For new installation

Calculate additional charge (E) for liquid line which is greater than 25 ft.

For system repairs

Calculate the total system charge amount (G).

1. Total line length = _____ ft (A)
 2. Standard line length = _____ 25 _____ ft (B)
 3. A minus B = _____ ft (C)
 4. Refrigerant multiplier = _____ 0.6 _____ oz/ft (D)
 5. Additional refrigerant amount(C*D) = _____ oz (E) *E=0 if line length is less than 25ft.
-
6. Factory charge on nameplate = _____ oz (F)
 7. Total system charge amount = _____ oz (G) **G=E+F**

13.2 Auto charge mode

Turn on the power supply for the system, select **cooling mode** from thermostat . Make sure the setting temperature is lower than room temperature for at least 5° F to finish this charge mode ***NOTE1**.
Press and hold BS4 button for five seconds until SEG1 displays blinking 7. After one minute, the system will go into AUTO charge mode ***NOTE2**.



Figure 13-1 LED display in AUTO charge assistant

Run the system for 15~20 minutes and check **refrigerant coefficient** number (here short for “X”, $0 < X < 1$) from the LED display. If $X > 0.6$, call back; or $X < 0.4$, add more refrigerant. Then wait for 5 minutes to allow system pressure balanced. Check the new coefficient number to make sure you get 0.5. Basically, 0.4 to 0.6 is acceptable if SH is no greater than 20° F.

When the LED displays “--” for more than 20 minutes, stop charging and check the TXV adjustment to ensure required compressor suction superheat (Refer to the following page).

[Refrigerant coefficient]

The refrigerant coefficient is used to evaluate the refrigerant level in the system.



[Use either way below to end AUTO charge mode]

Press **BS4 once**/ After 2 hours running (Automatically EXIT)/ Turn off the system from thermostat

NOTES:

- This AUTO charge mode is suitable for ambient temperature between 50~120 F. But for the best results, indoor temperature should be kept between 70~80 F.** For outdoor ambient temperature is below 50° F, use weigh-in charge method only. It is always suggested to check the charge amount and indoor TXV opening when outdoor ambient temperature is above 50° F.



Figure 13-2 Temperature limit for AUTO charge assistant

- Start-up control is enforced to complete prior to activate the AUTO charge mode. It may take 4 to 10 minutes to exit start-up control procedure and fix the compressor frequency(RPS).

Tips: How to adjust indoor TXV opening

To keep the best Ecoer Smart Inverter (ESI) systems' performance and reliability, be sure liquid line sub-cooling (SC) and compressor suction superheat (SH) meet our requirements.



**Target values
in cooling mode**



- If the LED displays "--" in AUTO charge mode for more than 20 minutes, stop charging and use a wrench to **clockwise** the TXV to ensure SH is no less than 7° F.
- In case that the cooling performance is abnormal due to improper superheat (i.e. SH >20° F). Adjust the system according to
 1. Activate AUTO charge mode from outdoor condensing unit to fix compressor frequency (RPS) by press BS4 for 5 seconds on PCB. Run the system for 15~20 minutes to check refrigerant coefficient number from LED display or ESS Pro App, **add refrigerant until you get 0.6**.
 2. Adjust TXV opening to allow more refrigerant flow into indoor coil if SH is still larger than 20° F. Open the front panel of the indoor unit, then remove the TXV nut and use a wrench to **counterclockwise** the TXV until SH ≤ 20° F.

NOTE: Maintain a minimum of 5 minutes' operation after every refrigerant charge or TXV opening adjustment, then check live SC and SH from Ecoer Smart Service Mobile App.

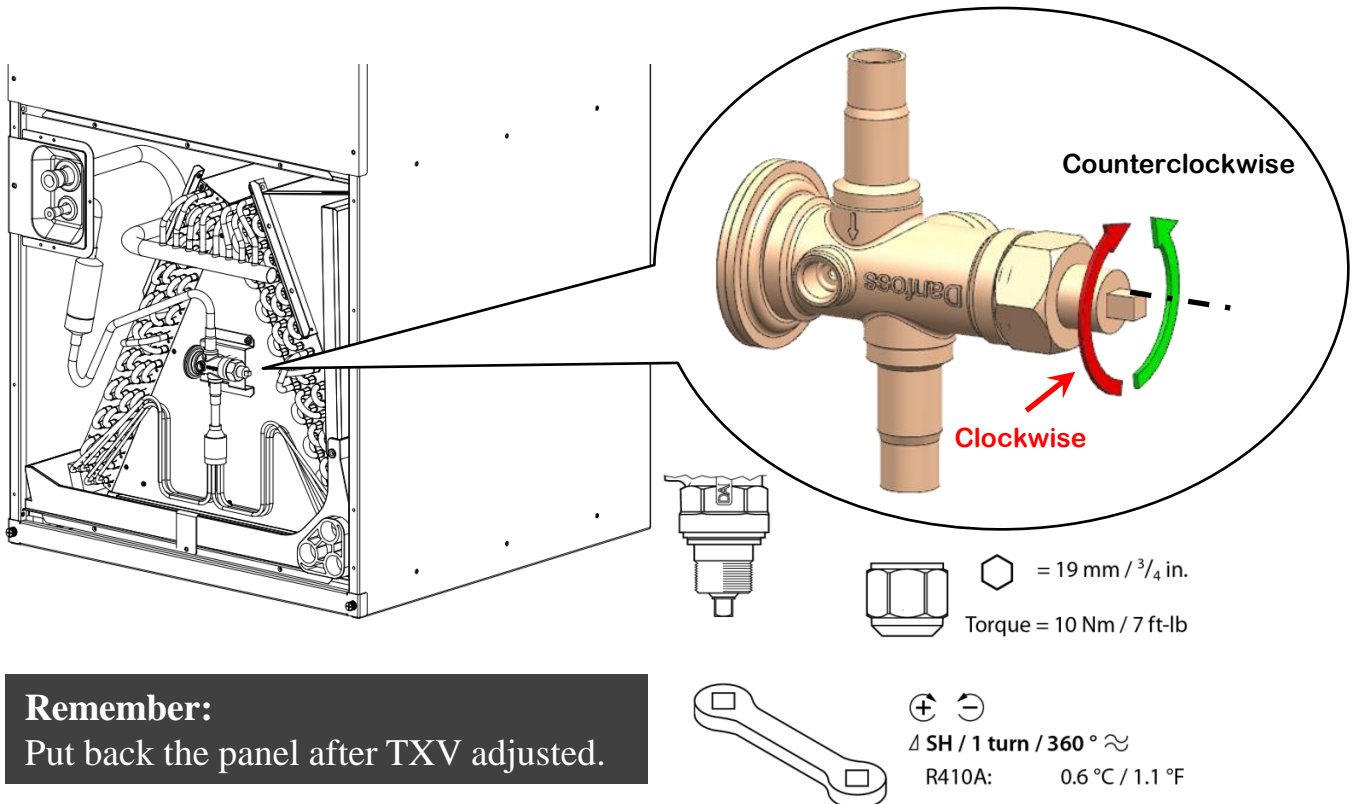

Figure 13-3 Adjust indoor TXV opening according to SC and SH

13.3 Sub-cooling charge

Refer to the following step to charge refrigerant by sub-cooling in cooling mode.

STEP1 Calculate superheat value on suction valve.

Measured suction line temperature = _____ °F

Measured suction line pressure = _____ PSIG

Calculate superheat value = _____ °F

Table 13-2 Superheat calculation on suction service valve

Suction line TEMP (°F)	Final Superheat (°F)							
	8	10	12	14	16	18	20	22
	Suction Gage Pressure (PSIG)							
40	101	97	93	89	86	82	78	75
42	105	101	97	93	89	86	82	78
44	110	105	101	97	93	89	86	82
46	114	110	105	101	97	93	89	86
48	118	114	110	105	101	97	93	89
50	123	118	114	110	105	101	97	93
52	128	123	118	114	110	105	101	97
54	133	128	123	118	114	110	105	101
56	138	133	128	123	118	114	110	105
58	143	138	133	128	123	118	114	110
60	148	143	138	133	128	123	118	114
62	153	148	143	138	133	128	123	118
64	159	153	148	143	138	133	128	123
66	164	159	153	148	143	138	133	128
68	170	164	159	153	148	143	138	133
70	176	170	164	159	153	148	143	138
72	182	176	170	164	159	153	148	143

STEP2 Calculate sub-cooling value on liquid valve.

Measured liquid line temperature = _____ °F

Measured liquid line pressure = _____ PSIG

Calculate sub-cooling value = _____ °F

Add refrigerant if calculated sub-cooling value is lower than the designed one. Repeat the steps above.

Table 13-3 Sub-cooling calculation on liquid service valve

Liquid line TEMP (°F)	Final Sub-cooling (°F)							
	6	7	8	9	10	11	12	13
	Liquid Gage Pressure (PSIG)							
55	173	176	179	182	185	188	191	195
60	188	191	195	198	201	204	208	211
65	204	208	211	215	218	221	225	229
70	221	225	229	232	236	239	243	247
75	239	243	247	251	255	259	262	266
80	259	262	266	270	275	279	283	287
85	279	283	287	291	295	300	304	309
90	300	304	309	313	318	322	327	331
95	322	327	331	336	341	346	351	355
100	346	351	355	360	365	370	376	381
105	370	376	381	386	391	397	402	407
110	397	402	407	413	418	424	430	435
115	424	430	435	441	447	453	459	465
120	453	459	465	471	477	483	489	496
125	483	489	496	502	508	515	521	528

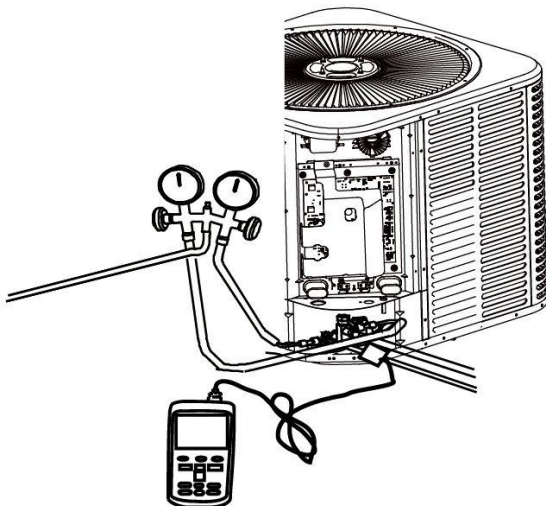

Figure 13-4 Measure the superheat or sub-cooling

Table 13-4 Designed sub-cooling degree

Model	2436	4860
Designed sub-cooling degree	10 °F(±2 °F)	8 °F(±2 °F)

STEP3 Adjust refrigerant level to attain proper gage pressure.

Add refrigerant if the sub-cooling is lower than the chart value.

1. Connect gage hoses to refrigerant tank and unit as illustrated.
2. Purge all hoses.
3. Stand the refrigerant tank upside-down and charge.
4. Stop adding refrigerant when sub-cooling matches the charging chart.

Recover refrigerant if the sub-cooling is higher than the chart value.

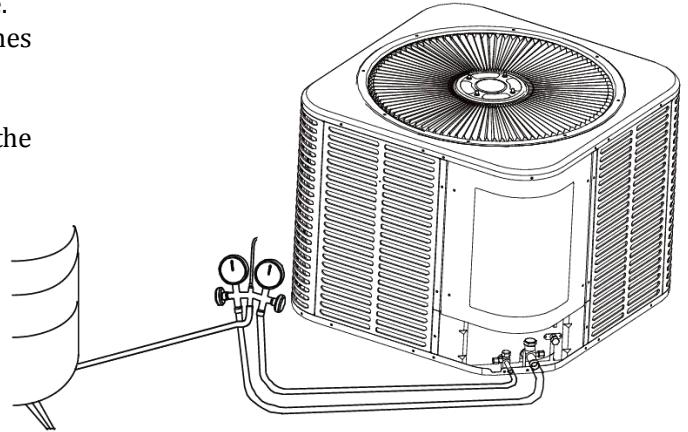

Figure 13-5 Charge the system

STEP4 Stabilize the system.

1. Wait five (5) minutes for the unit to stabilize between adjustments. When the sub-cooling matches the chart, the system is properly charged.
2. Remove gage hoses.
3. Replace and tighten service port caps to prevent leaks. Plus an additional 1/6 turn may be required.

STEP5 Record system information for further reference.

Outdoor model	
Measured outdoor ambient temperature	℉
Measured indoor ambient temperature	℉
Liquid gage pressure	PSIG
Suction gage pressure	PSIG
Measured suction line temperature	℉
Measured liquid line temperature	℉

14. System Operation

14.1 Default display

LED on main control board can display the operating status of outdoor unit (ODU).

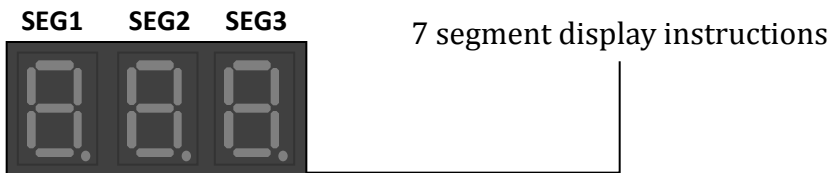

SEG1: Normally blank, but it displays codes “1~9” accordingly if there is damaged sensor and demand control requirement.

SEG1 Code	Description
0	Software is updating through IoT gateway
1	High pressure sensor (HP) fault backup running
2	Low pressure sensor (LP) fault backup running
3	Compressor discharge temperature sensor (TD) fault backup running
4	IPM module temperature sensor (TF) fault backup running
5	Ambient temperature sensor (TA) fault backup running
6	Defrost sensor (TH) fault backup running
7	Compressor suction temperature sensor (TS) fault backup running
8	Liquid line temperature sensor (TL) fault backup running
9	Demand response

SEG2: Normally blank, but it will display code accordingly as below if outdoor unit is running under limited condition.

SEG2 Code	Description
0	Running under high pressure limit
1	Running under low pressure limit
2	Running under discharge temperature limit
3	Running under IPM module temperature limit
4	Running under compressor current limit

SEG3: It displays outdoor unit’s operation mode.

SEG3 Code	Description
0	Stop without running signal (Y signal=OFF)
1	Ready to start after receiving running signal (Y signal=ON) *Note
2	Cooling mode
3	Heating mode
4	Oil return
5	Defrost
6	Manually forced defrost
7	AUTO charge assistant in cooling
8	Pump down in heating

Note: Compressor waits 3~6 minutes to restart.

Mode list (SEG3 Display)

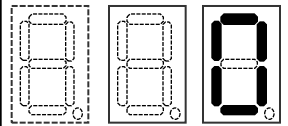
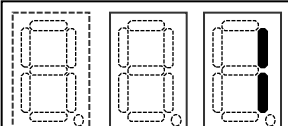
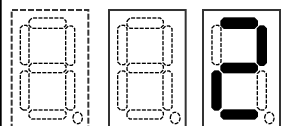
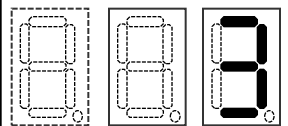
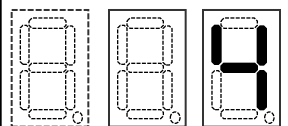
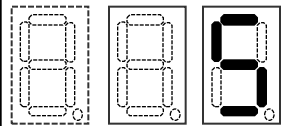
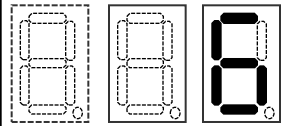
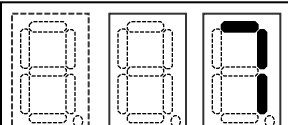
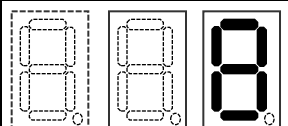
<p>Stop or standby without running signal (Y=OFF)</p>	<p>SEG1 SEG2 SEG3</p> 
<p>Wait to start after receiving running signal (Y=ON) (6 minutes for pressure equalization to restart)</p>	<p>SEG1 SEG2 SEG3</p> 
<p>Cooling running</p>	<p>SEG1 SEG2 SEG3</p> 
<p>Heating running</p>	<p>SEG1 SEG2 SEG3</p> 
<p>Oil return</p>	<p>SEG1 SEG2 SEG3</p> 
<p>Defrost</p>	<p>SEG1 SEG2 SEG3</p> 
<p>Forced defrost</p>	<p>SEG1 SEG2 SEG3</p> 
<p>AUTO charge assistant in cooling</p>	<p>SEG1 SEG2 SEG3</p> 
<p>Pump down in heating</p>	<p>SEG1 SEG2 SEG3</p> 

14.2 Field setting

Outdoor condensing units' functions can be applied by dipping switch and pressing buttons.

14.2.1 Setting by dip switches

SW1 Dip switch		Description	
NO.	Setting item	Status	Content
1	Reserved	-	-
2	Capacity selection *	ON	2 or 4 Ton
		OFF(factory)	3 or 5 Ton
3	AC only/Heat pump	ON	AC only
		OFF(factory)	Heat pump
4	Response for IoT command	ON	No
		OFF(factory)	Yes

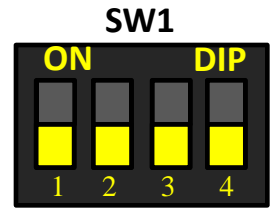

Use minor straight screwdriver to dip switch.

Power off the unit for at least two minute to activate this change.

* Keep the factory default ODU's dip switch for Ultra combination.

14.2.2 Setting by pressing buttons

Query and setting operation can be done by pressing buttons on main control board.

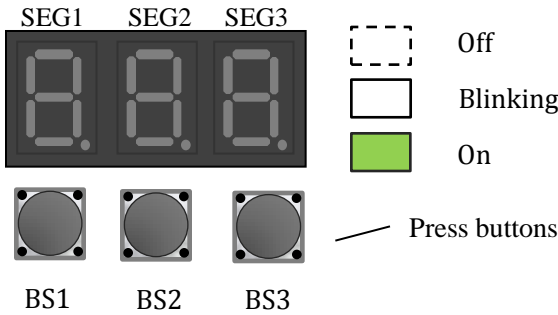

BS1: Menu or back button

BS2: UP button

BS3: Spot check and confirm button

Remarks:

Press or tip any directions are valid.

Press and hold BS1 for 5 seconds to set special functions.

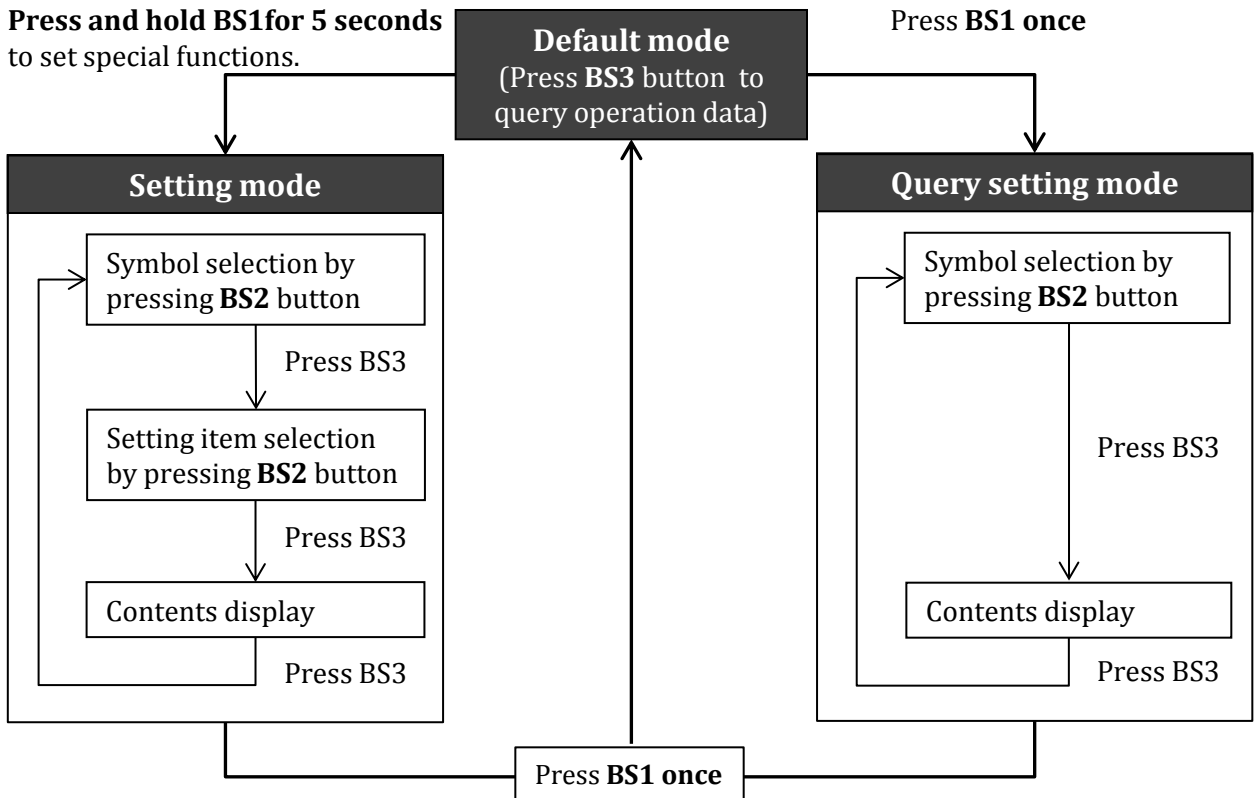

Default mode (Spot check)

System states can be showed on the 7 segments display (LED) of outdoor unit. Press **BS3** button to get code number and corresponding detailed information with an interval of one second.

Example: Code number



Detailed information

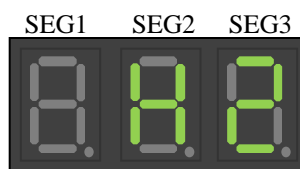

No.	Number content	Example	Description
Default	Refer to default display instructions	902	9: Demand 0: Running under high pressure limit 2: Cooling mode
01-	Outdoor unit type and capacity	H3	H: Heat pump C: AC only 3: 3Ton
02-	Liquid line sub-cooling	10	10°F
03-	Compressor suction superheat	18	18°F
04-	Compressor speed	56	56RPS
05-	Electronic expansion valve opening	360	360pls
06-	Step of fan	8	The 8th step
07-	Low pressure (LP sensor)	145	145psig
08-	High pressure (HP sensor)	350	350psig
09-	Outdoor ambient temp. (TA)	95	95°F
10-	Compressor suction temp. (TS)	70	70°F
11-	Compressor discharge temp. (TD)	170	170°F
12-	Defrost sensor temp. (TH)	80	80°F
13-	Liquid line temp. (TL)	70	70°F
14-	Inverter module temp. (TF)	150	150°F
15-	Target evaporating temp. (Tes)	43	43°F
16-	Current evaporating temp. (Te)	45	45°F
17-	Target condensing temp. (Tcs)	104	104°F
18-	Current condensing temp. (Tc)	112	112°F
19-	Compressor DC current	10.1	10.1A
20-	Undercharged refrigerant signal	0	0: none 1: level 1 2: level 2 (severe)
21-	Main software version	A01	A01 version
22-	Inverter software version	b01	b01 version
23-	Current fault	E1	Display up to 5 *
24-	The last fault	F1	--: none
25-	Fault before the last fault	F2	--: none

Remark:

When multi-error codes exist at the same time, each code will be displayed one by one with an interval of one second.

Setting mode

Press and hold **BS1** button for 5 seconds to enter the parameter setting interface. The latest setting will be taken as the final one.

Symbol	Function	Item	Description
n00	Mode choice	0 (factory)	Normal mode
		1	Dry mode *1
		2	High capacity mode *2
n01	Forced heating stop when ambient temperature is lower than specific value. Changing to heat by gas furnace or boiler in cold winter.	0	Stop heat pump when TA<-22°F
		1 (factory)	Stop heat pump when TA<-3°F
		2	Stop heat pump when TA<15°F
		3	Stop heat pump when TA<30°F
		4	Stop heat pump when TA<40°F
n02	Outdoor unit outputs 24VAC from W terminal (CN5) at defrost operation or forced heating stop.	0 (factory)	ON (24VAC output)
		1	OFF (No 24VAC output)
n03	Outdoor unit outputs 24VAC from W terminal (CN5) when ambient temperature is lower than specific value to start indoor auxiliary heater.	0 (factory)	TA<15°F (24VAC output)
		1	TA<30°F (24VAC output)
		2	TA<40°F (24VAC output)
		3	TA<-3°F (24VAC output)
		4	OFF (No 24VAC output)
n04	Defrost mode setting *3	0	Defrost in heavy snow area
		1 (factory)	Standard mode
		2	Defrost in light snow area
n05	Silent mode setting	0 (factory)	None silent mode
		1	Silent mode (level 1)
		2	Super silent mode (level 2)
		3	Night silent mode (level 1)
		4	Night super silent mode (level 2)
n06	Night silent setting- start time	0	17:00
		1 (factory)	18:00
		2	19:00
		3	20:00
		4	21:00
n07	Night silent setting- end time	0	5:00
		1 (factory)	6:00
		2	7:00
		3	8:00
		4	9:00
n08	Forced defrost	0 (factory)	OFF
		1	ON *4

Remarks:

1. The evaporating temperature of indoor coil can lower down to 28 ℉.
2. The evaporating temperature of indoor coil can lower down to 28 ℉ in cooling mode, and the condensing temperature can go up to 122 ℉ in heating mode.
3. Reduce 10% heating time for heavy snow area, increase 10% heating time for light snow area.
4. System enters defrost after the heating start-up and an extra five minutes' control.

14.3 Major components function

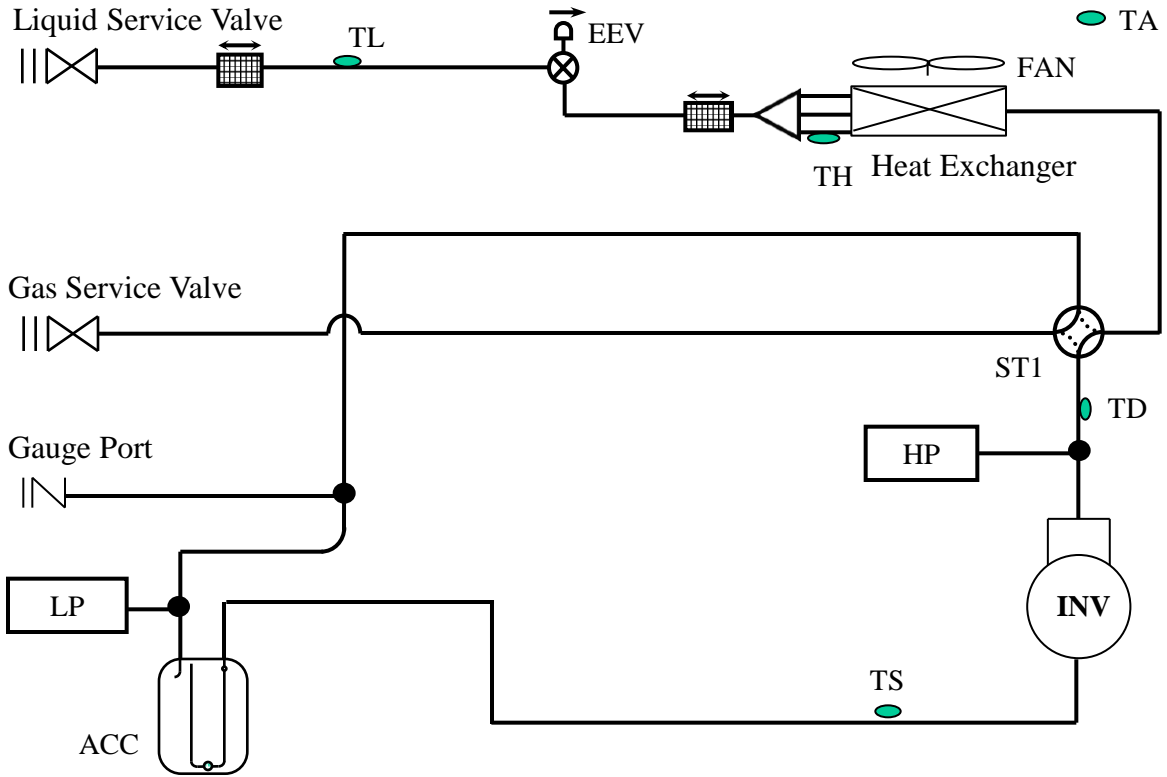

Figure 14-1 Refrigerant Circuit

Name	Symbol	Function
Inverter compressor	INV	Adjusts refrigerant flow rate by changing the speed (RPS) based on objective pressure.
DC motor	FAN	Outputs heat exchanger capacity by adjusting the motor rotation speed based on operating pressure.
Electronic expansion valve	EEV	1) Fully open during cooling mode and defrost operation. 2) Control compressor discharge superheat in heating mode.
Reversing valve	ST1	Switches the operation mode between heating and cooling (including defrost control).
Temperature sensor	TH	Uses to control defrosting during heating operation.
	TA	Uses to detect outdoor air temperature and control fan speed.
	TS	Uses to detect compressor suction temperature and calculate compressor suction superheat (SH).
	TL	Uses to detect liquid line temperature and calculate sub-cooling (SC).
	TD	Uses to detect compressor discharge temperature and calculate discharge superheat (DSH).
	TF	Uses to detect heat sink temperature of inverter module.
High pressure sensor	HP	Uses to detect high pressure.
Low pressure sensor	LP	Uses to detect low pressure.
Accumulator	ACC	Uses to store excess refrigerant.

14.4 Control logic description

14.4.1 Operation Mode

SW1_3=OFF (factory), ESI system uses Y/O/C signal to operate heat pump function.

SW1_3=ON has been set, ESI system uses Y/C signal to run cooling only.

Normal Operation:

- Compressor PI control
- EEV PI control
- Fan motor control
- Protection control

More detailed information can be found on ESI (Ultra) service manual.

14.4.2 Compressor control

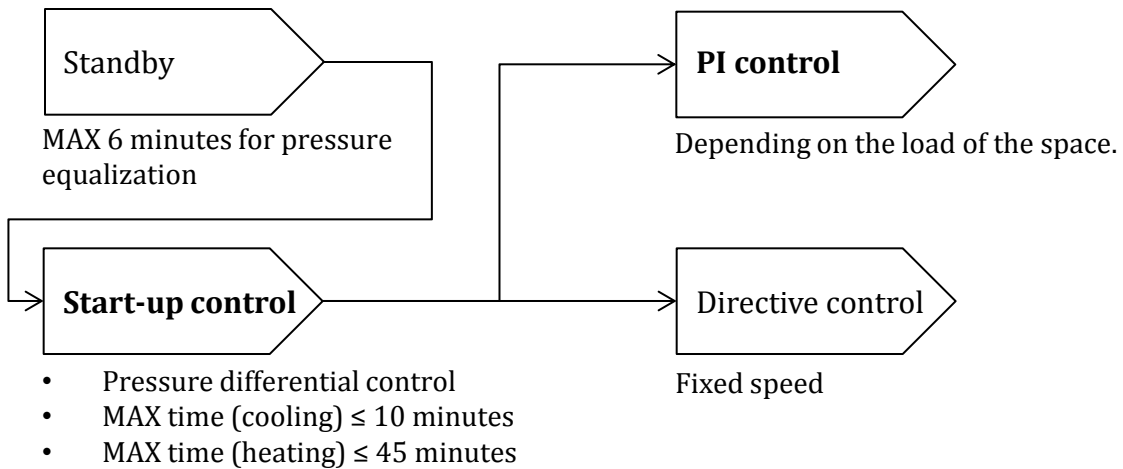

Outdoor Capacity	2 Ton	3 Ton	4 Ton	5 Ton
Cooling/Heating Min RPS	16	16	16	16
Cooling Max RPS	70	80	66	76
Heating Max RPS	80	90	80	90

14.4.3 Electronic expansion valve(EEV) control

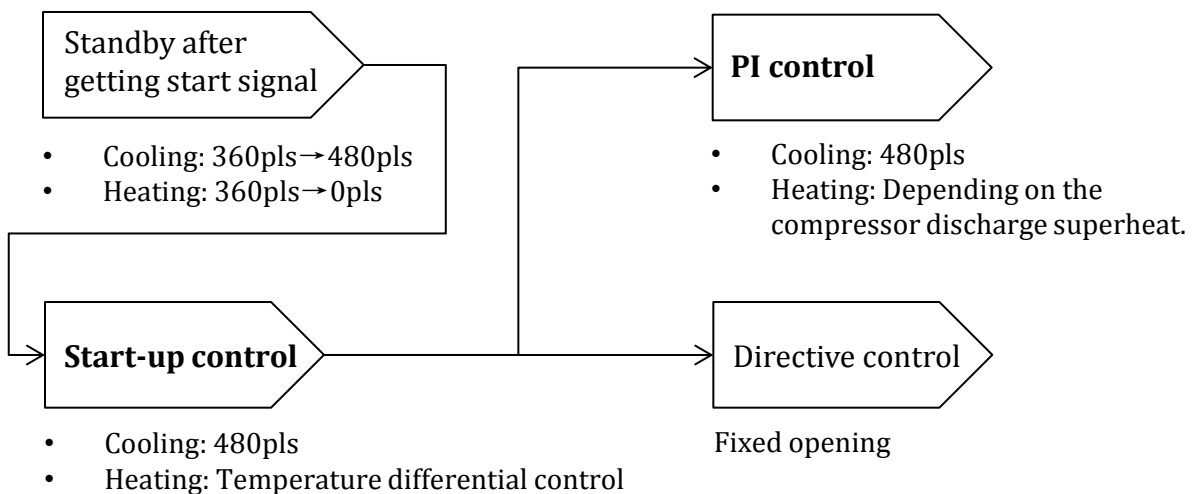

15. Trouble Shooting

If the system does not properly operate besides any malfunctions. Check the system based on the following procedures.

Symptoms	Possible causes	Solutions
System does not start-up but the digital tube shows normally	<ul style="list-style-type: none"> No 24 VAC signal from thermostat. Incompatible thermostat. 	<ul style="list-style-type: none"> Be sure Y/O/C wirings are connected correctly and the cooling/heating setting temperature from thermostat is proper. Use another 24 volts common thermostat.
System operates mode reversely	<ul style="list-style-type: none"> Incorrect O/B signal selection. 	<ul style="list-style-type: none"> Choose O for cooling from thermostat.
System cannot cool well	<ul style="list-style-type: none"> Outside temperature is too high. Outside temperature is too low. Dirty air filter or blocked outlet of indoor unit. Too little refrigerant in the system. Too big comp. suction superheat. 	<ul style="list-style-type: none"> Normal protection control to limit RPS Ensure the cooling load Replace the air filter and eliminate any obstacles. Check refrigerant amount or any leaks. Counterclockwise the TXV (Make sure the refrigerant coefficient is 0.6)
System cannot heat well	<ul style="list-style-type: none"> Outside temperature is too low but no third-party heater inside. The outdoor coil is dirty or has been covered by heavy snow. Dirty air filter. Micro channel coil has been used in heating Lack of refrigerant. 	<ul style="list-style-type: none"> Install auxiliary heater for backup *Dual-heating is recommended. Clean the outdoor coil. Replace the air filter. No micro channel coils shall be used for heat pump. Check refrigerant amount or any leaks.

Remarks:

ESI(Ultra) systems are compatible with most common 24V controlled thermostats.

Reversing valve de-energized in cooling mode.

Reversing valve energized (208/230Vac) in heating mode.

Error code List for Outdoor Unit

Past error codes can be spot check by BS3 button, and seen from Ecoer Smart Service Pro App. **Sign in App->Files->Service, refer to ESI (Ultra) service manual for trouble shooting details.**

Code	Description	Legend
P1	High pressure protection	
E1	System locks up when P1 has occurred six times in 3 hours.	Cannot restart *1
P2	Low pressure protection in cooling mode	
E2	System locks up when P2 has occurred six times within 3 hours.	Cannot restart *1
P3	Compressor discharge temperature (TD) protection	
E3	System locks up when P3 has occurred six times within 3 hours.	Cannot restart *1
P4	Compressor discharge temperature (TD) sensor is disconnected or damaged	
P5	Inverter module temperature (TF) protection	
E5	System locks up when P5 has occurred six times within 3 hours.	Cannot restart *1
P6	Compressor over-current protection	
E6	System locks up when P6 has occurred six times within 3 hours.	Cannot restart *1
P7	Liquid slugging protection	
E7	System locks up when P7 has occurred three times within 5 hours.	Cannot restart *1
P8	Low compressor voltage protection	
E8	System locks up when P8 has occurred three times within 60 minutes.	Cannot restart *1
P9	Incorrect compressor line sequence	Cannot restart *1
PA	DC fan motor over-load protection	Cannot restart *1
F1	Ambient temperature (TA) sensor fault	Backup running*2
F2	Compressor suction temperature (TS) sensor fault	Backup running*2
F3	Liquid line temperature (TL) sensor fault	Backup running*2
F4	Defrost temperature (TH) sensor fault	Backup running*2
F5	Compressor discharge temperature (TD) sensor fault	Backup running*2
F6	Inverter module temperature (TF) sensor fault	Backup running*2
F7	High pressure (HP) sensor fault	Backup running*2
F8	Low pressure (LP) sensor fault	Backup running*2
E4	Communication fault between main chip and INV drive chip	Cannot restart *1
H1	Ambient temperature limit operation in cooling mode	
H2	Ambient temperature limit operation in heating mode	
H3	Abnormal switch alarm for 4-way valve	Just show alarm
H4	Defrost temperature (TH) sensor is disconnected or damaged	
H5	EEPROM fault	
H6	Low voltage alarm	
HF	Abnormal function control	Alarm
C0-CC	Compressor INV module protection	
E0	System locks up when C0~CA has occurred three times within 60 minutes.	Cannot restart *1

Remarks:

1. Disconnect power supply switch for 5 minutes to reset, then turn on power supply for the system.
2. System goes to backup running under sensors fault varies from 7 to 120 days. Allow up to two sensors backup running at the same time.

16. Wiring Diagram

EODA18H-2436

231311491
AUG 2018 V1.5

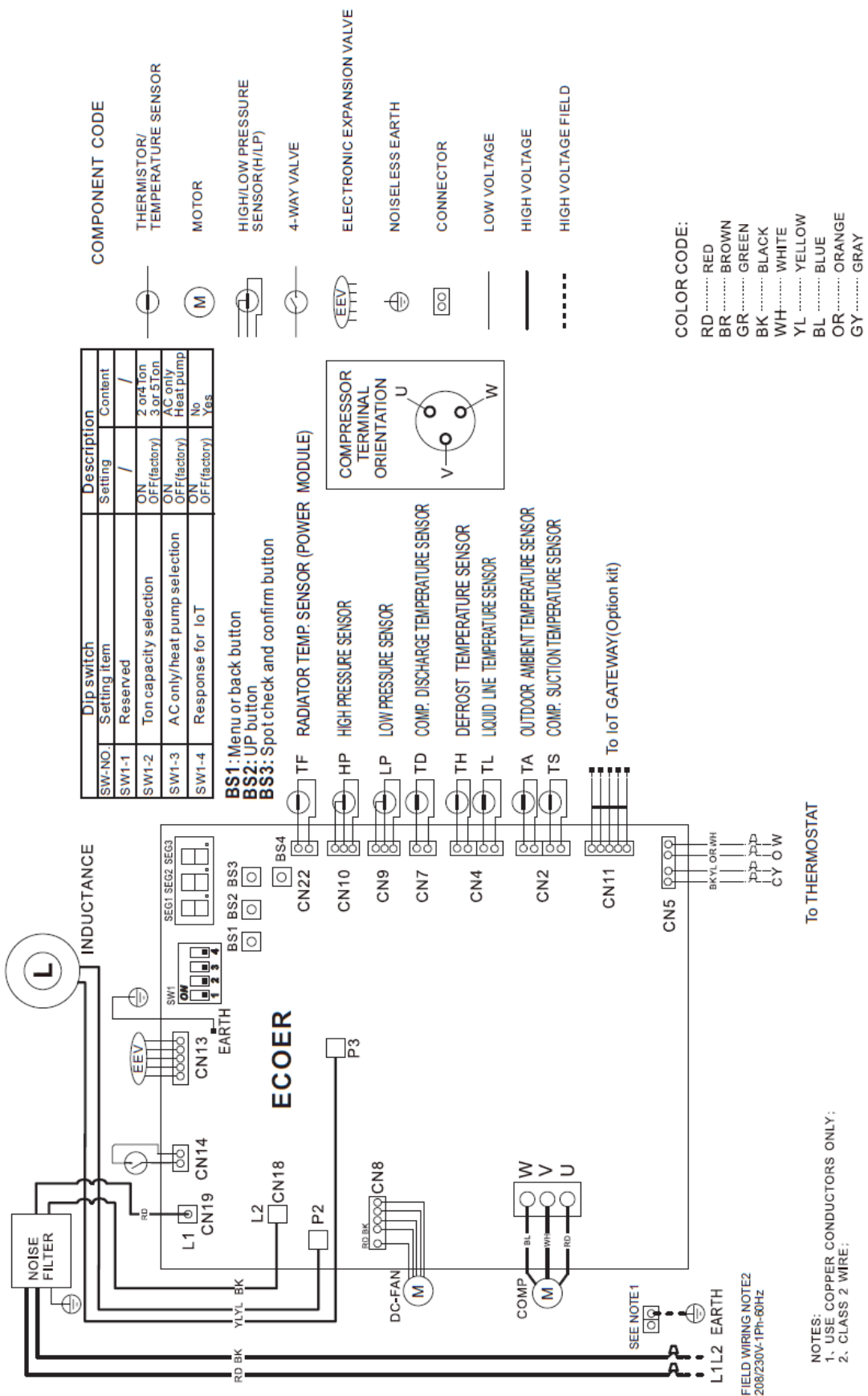

High Voltage: Disconnect all power before servicing or installing this unit. Multiple power sources may be present. Failure to do so may cause property damage, personal injury, or death. Wiring is subject to change. Always refer to the wiring diagram or the unit for the most up-to-date wiring.

WARNING

EODA18H-4860

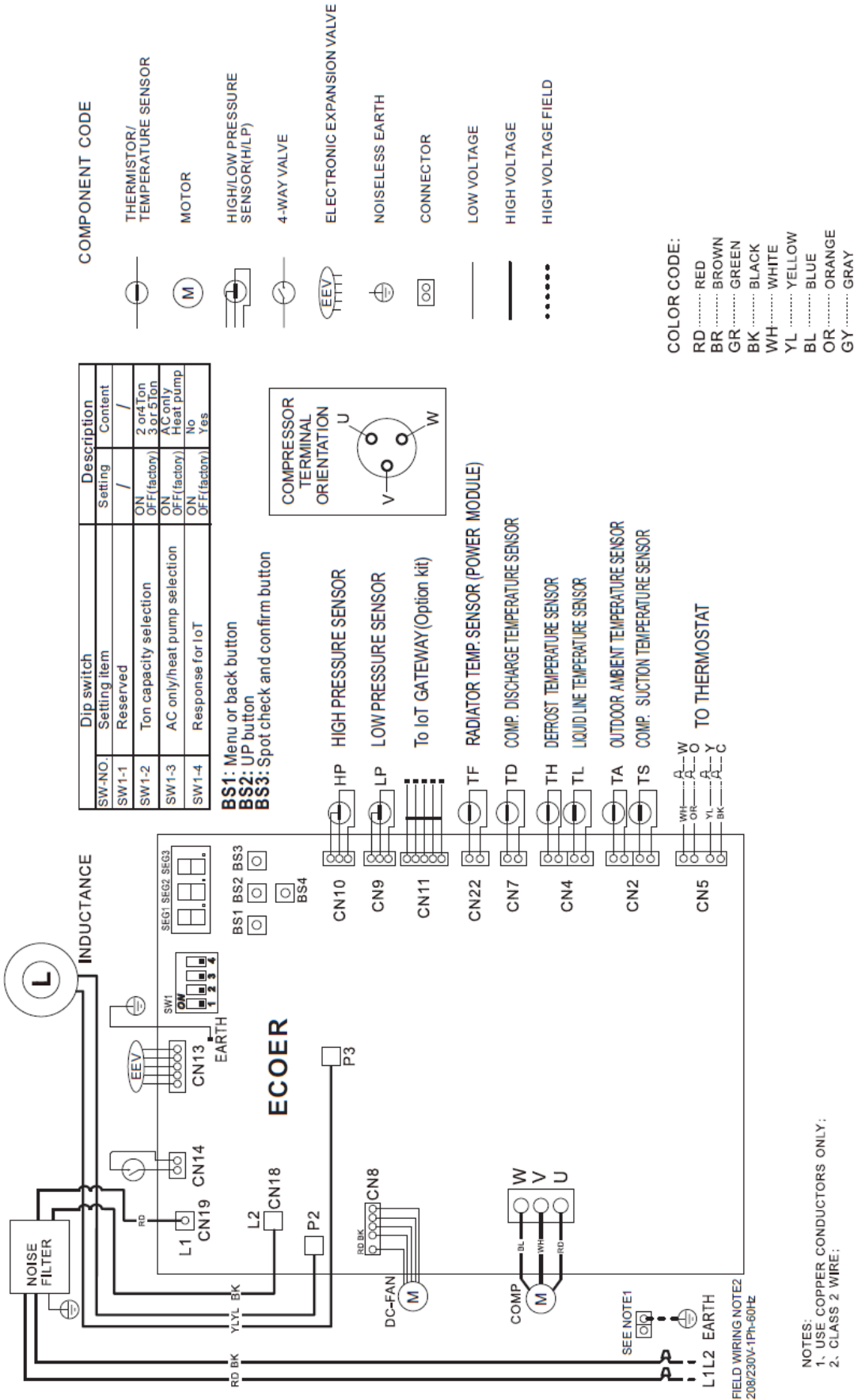

231311490
AUG 2018 V1.5

High Voltage: Disconnect all power before servicing or installing this unit. Multiple power sources may be present. Failure to do so may cause property damage, personal injury, or death. Wiring is subject to change. Always refer to the wiring diagram or the unit for the most up-to-date wiring.

WARNING

- NOTES:
 1. USE COPPER CONDUCTORS ONLY;
 2. CLASS 2 WIRE;

©2017-2019 ECOER INC.

3900 Jermantown Rd., Suite 150, Fairfax, VA 22030

Tel: 703-348-2538

www.ecoer.com