

# Installation Instructions

AIR HANDLER UNITS

3-5Ton Capacity

TXV Inside

Suitable for R410A System

---

## Contents

1. Safety-----	2
2. Dimensions -----	4
3. Applications-----	6
4. Electrical Wiring-----	9
5. Airflow Performance-----	13
6. Ductwork-----	14
7. Pipe Connections-----	15
8. Air Filter-----	16
9. TXV Adjustment -----	17

**NOTE: Appearance of unit may vary.**

Installation must be performed in accordance with the requirements of NEC and CEC by authorized personnel only.

All phases of this installation must comply with National, State and Local Codes.

This document is customer’s property and is to remain with this unit. Please return it to customer with service information upon completion of work.

These instructions are intended as an assist to qualified and licensed personnel for proper installation, adjustment and operation of ECM air handler units. Read it thoroughly before attempting installation or service work. **Failure to follow these instructions may result in fire, electrical shock, property damage, personal injury or death.**

The instructions do not cover all variations in systems or provide for every possible contingency to be met in connection with the installation.



# 1. Safety

Read the following safety instructions before installing the unit or doing service work.

 **WARNING** may cause personal death or serious injury.

 **CAUTION** may lead to injury or structural damage under some conditions.

## **WARNING**

Disconnect all power to unit before installing or servicing. More than one disconnecting switch may be required to de-energize the equipment. Hazardous voltage can cause server personal injury or death.

Installation and maintenance must be performed by authorized personnel only.  
Consumer service is recommended only for filter cleaning/replacement. Never operate the unit with the access panels removed.

Failure to inspect pipes or use proper service tools may result in equipment damage or personal injury. If using existing refrigerant pipes, make sure that all joints are brazed, not soldered.

The unit must be permanently grounded.  
Failure to do so can result in electrical shock causing personal injury or death.

**PROPOSITION 65:** This appliance contains fiberglass insulation. Respirable particles of fiberglass are known to State of California to cause cancer. All manufacturer products have to meet current federal OSHA Guidelines for safety.

California Proposition 65 warnings are required for certain products that are not covered by the OSHA standards. It requires warnings for products sold in California that contain or produce any of over 600 listed chemicals known to the State of California to cause cancer or birth defects such as fiberglass insulation, lead in brass, and combustion products from natural gas.

All “new equipment” shipped for sale in California will have labels stating that the product contains and /or produces Proposition 65 chemicals. Although we have not changed our processes, having the same label on all our produced facilitates manufacturing and shipping. We cannot always know “when or if” products will be sold in the California market. You may receive inquiries from customers about chemicals found in, or produced by, some of our heating and air-conditioning equipment, or found in natural gas used with some of our products. Listed below are those chemicals and substances commonly associated with similar equipment in our industry and other manufacturers.

- Glass Wool (Fiberglass) Insulation
- Carbon Monoxide (CO).
- Formaldehyde
- Benzene

More details are available at the websites for OSHA (Occupational Safety and Health Administration), at [www.osha.gov](http://www.osha.gov) and the State of California’s OEHHA (Office of Environmental Health Hazard Assessment) at [www.oehha.org](http://www.oehha.org). Consumer education is important since the chemicals and substances on the list are found in our daily lives. Most consumers are aware that products present safety and health risks, when improperly used, handled and maintained.



## WARNING

If removal of the blower assembly is required, all switches supplying power to the equipment must be disconnected and locked so the field power wires can be safely removed from the blower assembly. Failure to do so can cause electrical shock resulting in personal injuring or death.

Make sure the blower motor support is tight (3-motor mount bolts), then check if the wheel is secure to motor shaft before operating unit.

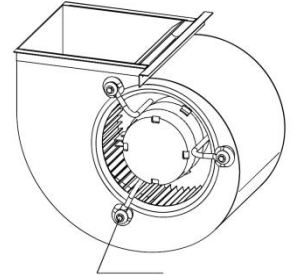

BLOWER MOTOR SHIPPING BOLT

The first 6 inches of supply air plenum and ductwork must be constructed of sheet metal as required by NFPA 90B. The supply air plenum or duct must have a solid sheet metal bottom directly after the air handler unit with no openings, registers or flexible air ducts located in it. If flexible supply air ducts are used, they may be located only in the vertical walls of rectangular plenum, a minimum of 6 inches from the solid bottom. Metal plenum or duct may be connected to the combustible floor base, if not, it must be connected to the unit supply duct exposed to the supply air opening from the down-flow unit.

Exposing combustible (non-metal) material to the supply opening of a down-flow unit may cause a fire resulting in property damage, personal injury or death.

# 2. Dimensions

**NOTE:** 25" CLEARANCE IS REQUIRED IN THE FRONT OF THE UNIT FOR FILTER AND COIL MAINTENANCE.

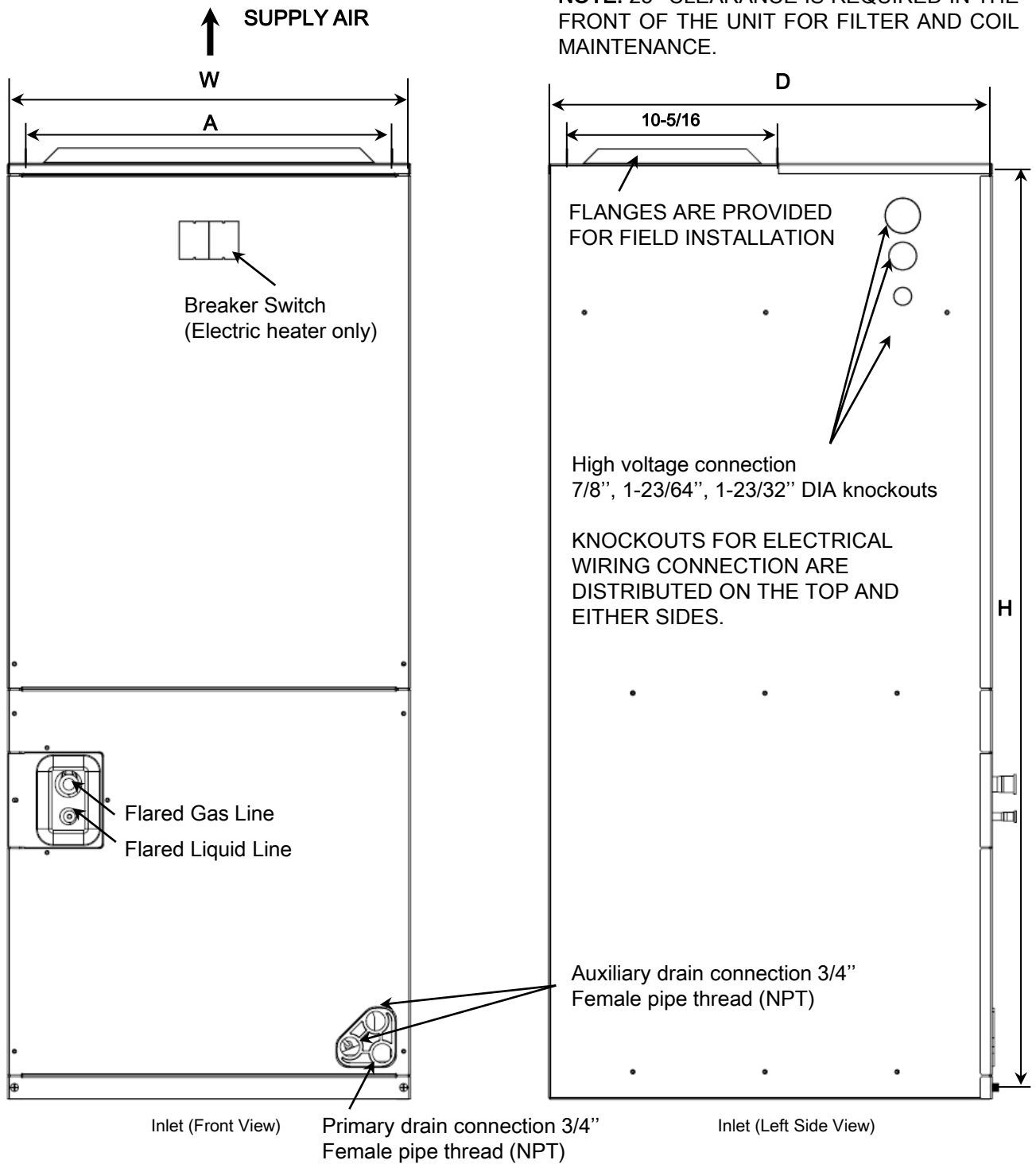

Figure 2-1 Unit Dimensions

Model	Dimensions(in.)					
	H	W	D	A	Liquid Line Connection	Gas Line Connection
36	46-1/2	19-5/8	21-5/8	18	3/8	3/4
60	54-1/2	22	24	19-1/2	3/8	7/8

The unit can be positioned for bottom return air in the up-flow position and top return in down-flow position. As well as left and right return in the horizontal position.

Adjustable motor speed tap through DIP switch to select correct air flow according to blower performance table.

Select a solid and level site, keep enough space for proper installation and maintenance.

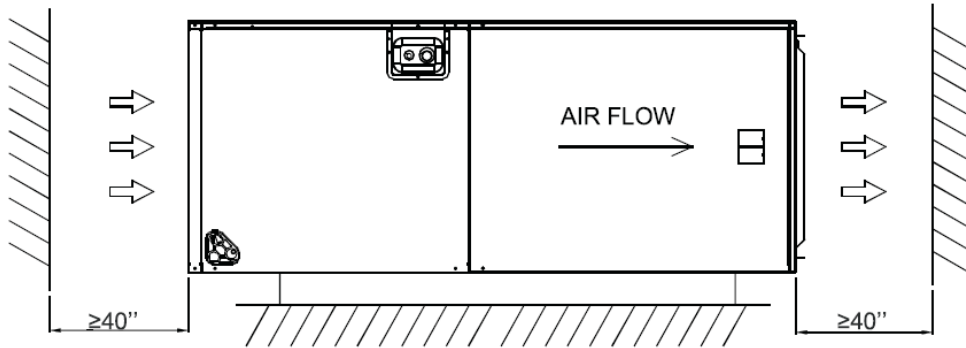

a) Horizontal Position

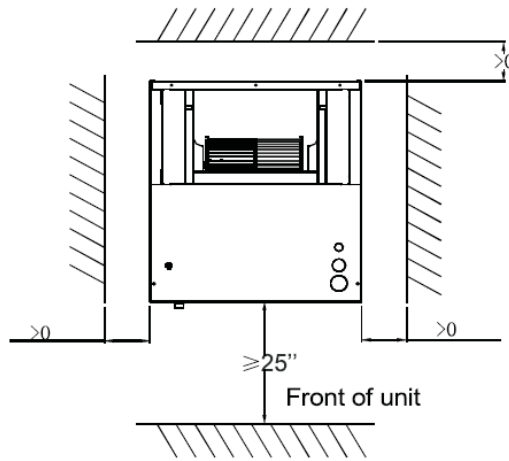

b) Vertical Position

Figure 2-2 Clearance requirement

## 3. Applications

### 3.1 Vertical up-flow

Vertical up-flow configuration is the factory set on all models.

If return air is to be ducted, install duct flush with floor. Use fireproof resilient gasket 1/8 to 1/4 in. thick between the ducts, unit and floor. Set unit on floor over opening.

#### IMPORTANT

Lightly tighten the drain connections so it won't leak.

Using excessive force may cause damage to the drain connections. Torque applied to drain connections should not exceed 15.ft.lbs.

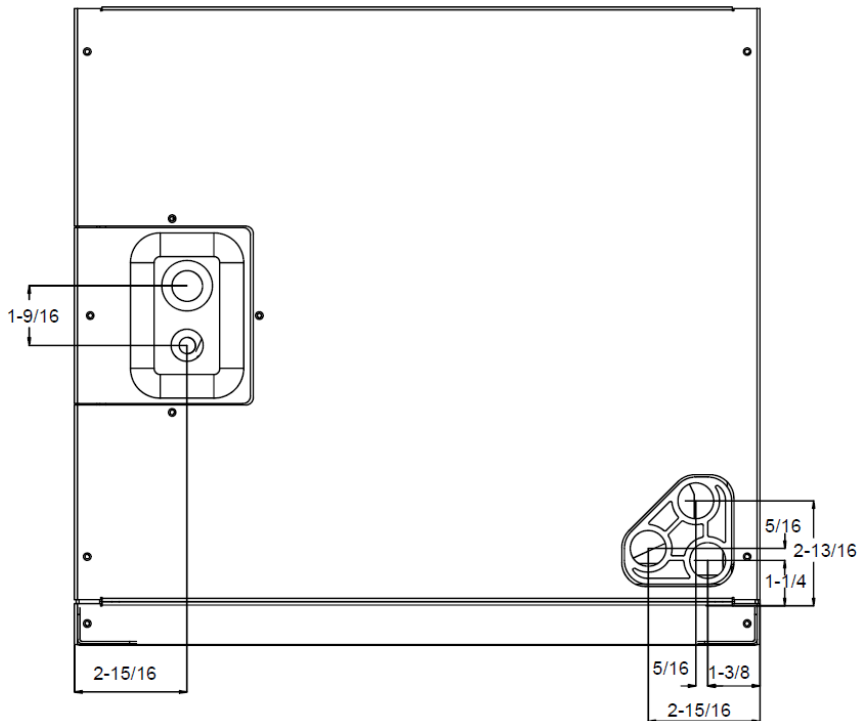

Figure 3-1 Dimensions for front connection coil

### 3.2 Vertical down-flow

A vertical up-flow unit may be converted to vertical down-flow. Remove the front panel and take out the indoor coil assembly with drain pan, reinstall 180° from original position (Fig. 3-2 and 3-3).

#### IMPORTANT

To comply with safety standards and the National Electrical Code for down-flow application, the circuit breaker(s) on field-installed electric heater kits must be re-installed so that the breaker switch "ON" position marking is up and "OFF" position marking is down.

#### CAUTION

When using the unit with electric heater kits, the switch is used only for electric heaters on the front of panel.

### 3.3 Horizontal left-flow

Horizontal right-flow is another default factory configuration for the units. These units may be converted to horizontal left-flow by removing indoor coil assembly with drain pan and reinstalling it as shown below.

- Rotate the unit 90° into the horizontal left position, with the coil compartment on the right and the blower compartment on the left.
- Reinstall the indoor coil 180° from original position. Ensure the retaining channel is fully engaged with the coil rail(Fig. 3-2 and 3-3).
- Secondary drain pan kits are required when the unit is configured for the horizontal position over a finished ceiling and/or living space.

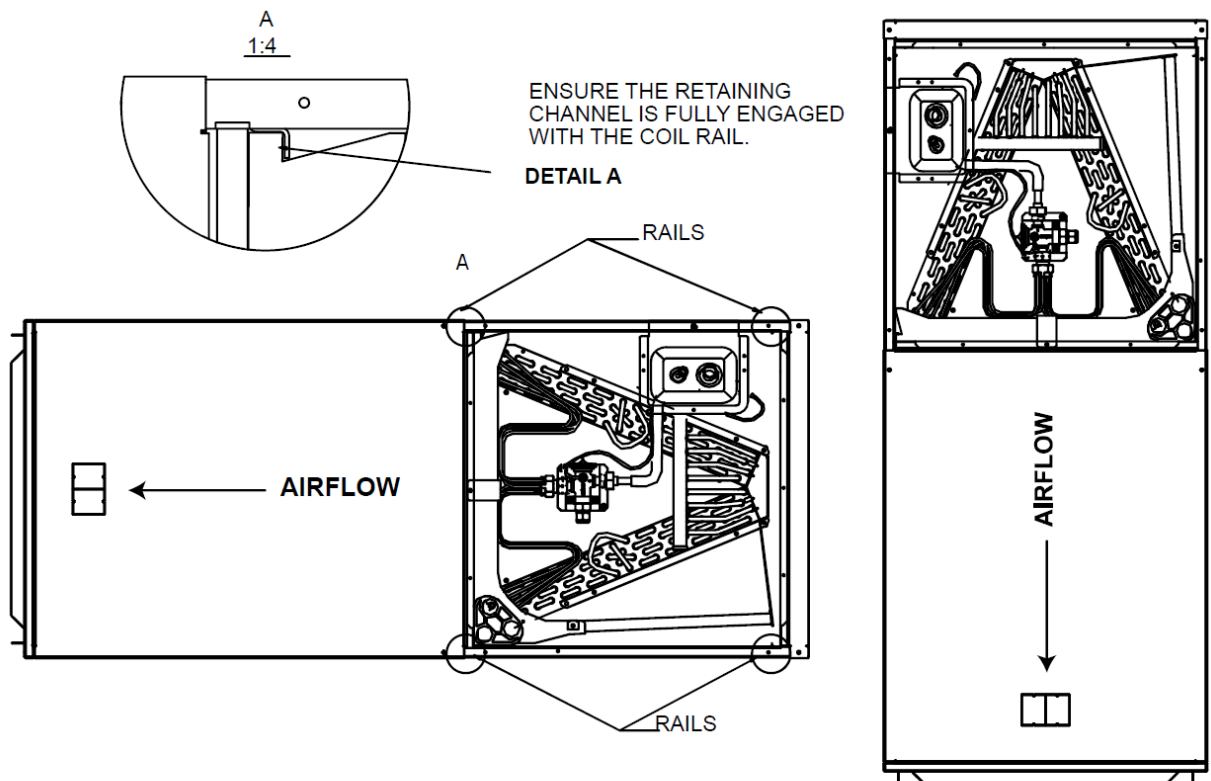

Figure 3-2 Horizontal left-flow and vertical down-flow and application

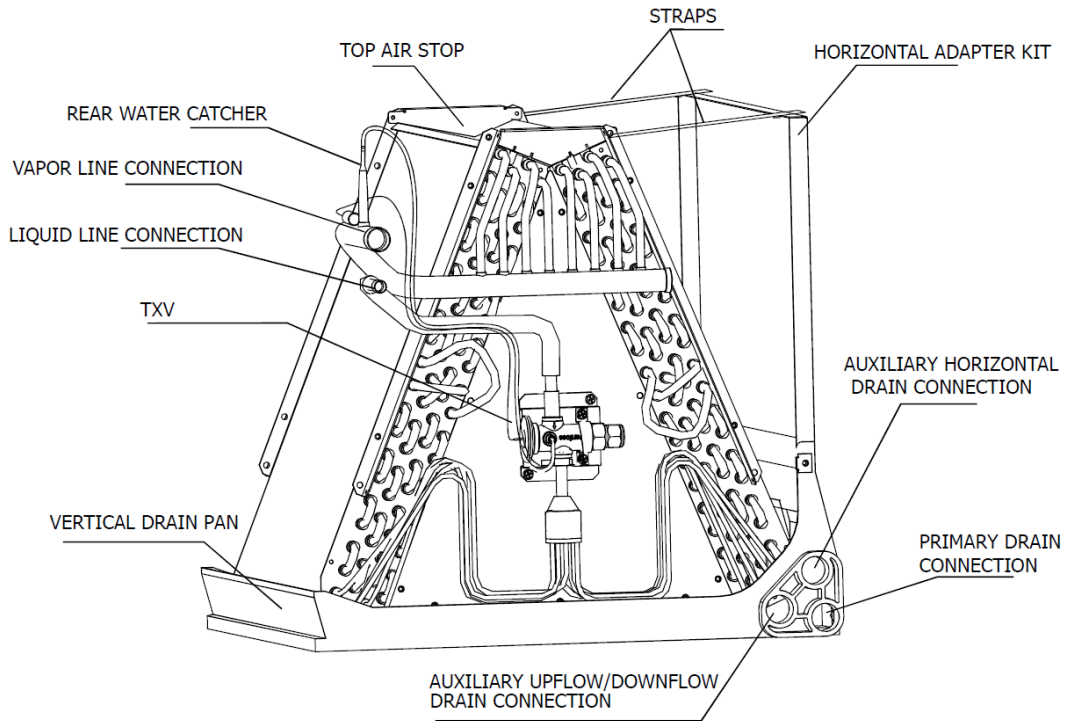

Figure 3-3 Dimensions for front connect coil

**CAUTION**

Horizontal units must be configured for right hand air supply or left hand air supply.

Horizontal drain pan must be located under indoor coil. Failure to use the drain pan can result in property damage.

### 3.4 Installation in an unconditioned space

There are two pairs of coil rails in the air handler for default and counter flow application. If the air handler is installed in an unconditioned space, the two unused coil rails should be removed to minimize air handler surface sweating. The coil rails can be easily removed by taking off the 6 mounting screws from both sides of the cabinet.



# 4. Electrical Wiring

Field wiring must comply with the National Electric Code (C.E.C. in Canada) and any applicable local ordinance.

## WARNING

Disconnect all power to unit before installing or servicing. More than one disconnect switch may be required to de-energize the equipment. Hazardous voltage can cause severe personal injury or death.

## 4.1 Power Wiring

It is important that proper electrical power is available for connection to the unit model being installed. Refer to the unit nameplate, wiring diagram and electrical data in the installation instructions.

- If required, install a branch circuit disconnect of adequate size, located within sight of, and readily accessible to the unit.
- When the electric heater is installed, units may be equipped with one or two 30~60 amp. circuit breakers. These breakers protect the internal wiring in the event of a short circuit and serve as a disconnect. Circuit breakers installed within the unit do not provide over-current protection of the supply wiring and therefore may be sized larger than the branch circuit protection.
- Supply circuit power wiring must be 167° F minimum copper conductors only. Refer to electrical data in this section for ampacity, wire size and circuit protector requirements. Supply circuit protective devices may be either fuses or “HACR” type circuit breakers.

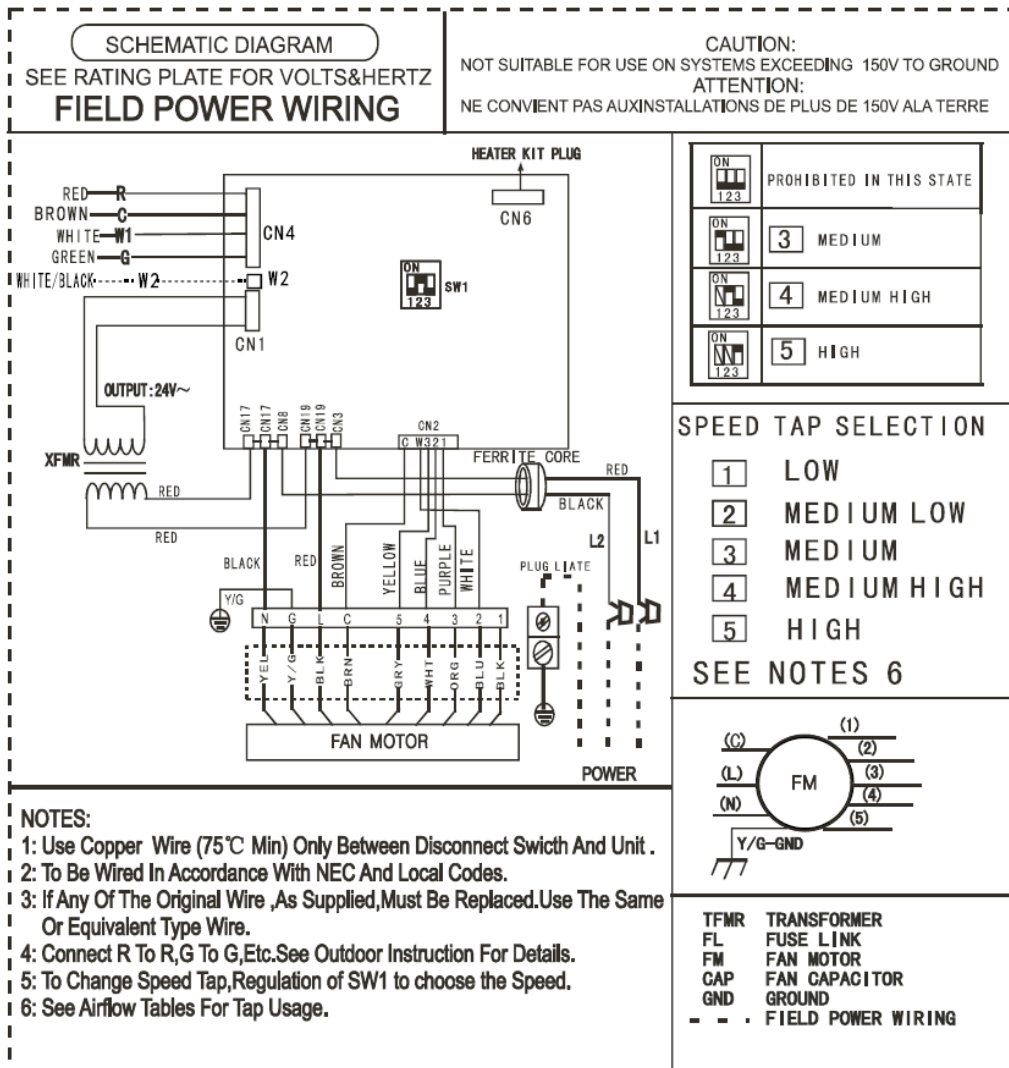
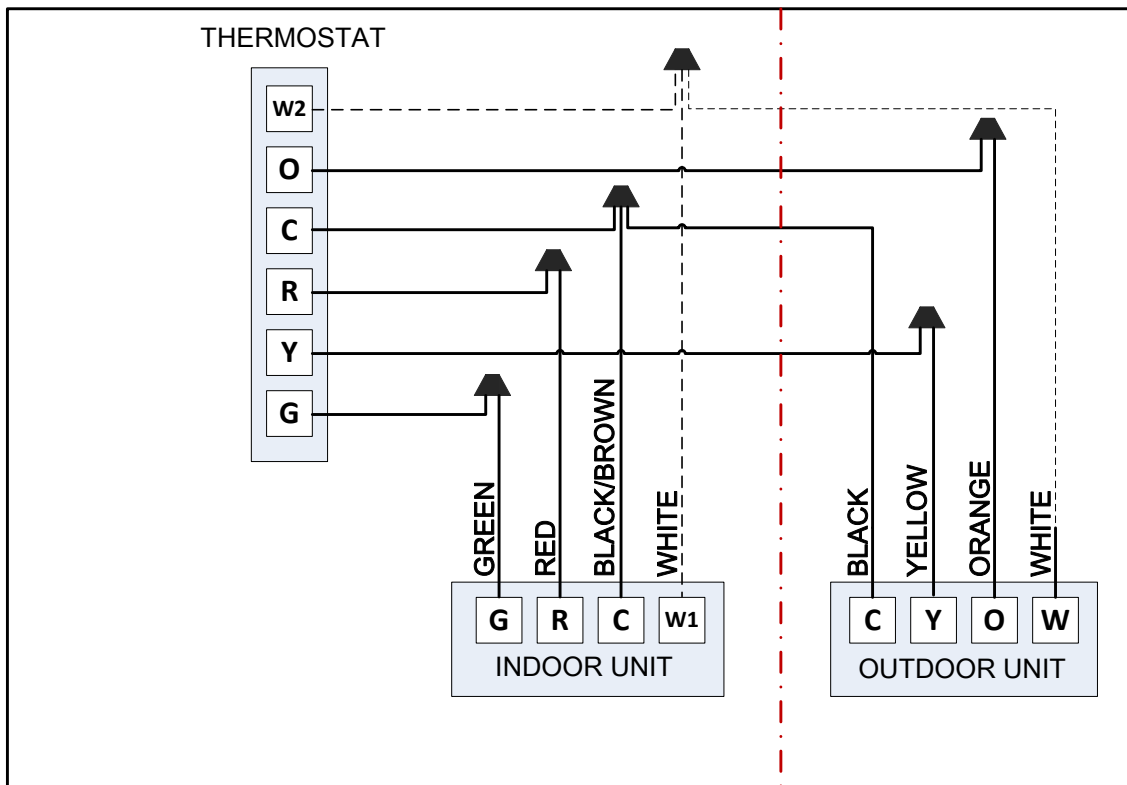

Figure 4-1 Wiring Diagram

## 4.2 Control Wiring

Class 2 low voltage control wiring should not be run in conduit with main power wiring and must be separated from power wiring, unless class 1 wire of proper voltage rating is used.

- Low voltage control wiring should be color-coded **18 AWG**. For lengths longer than 100 ft., 16 AWG. wire should be used.
- Refer to wiring diagrams attached to indoor and outdoor sections to be connected.
- Make sure separation of control wiring and power wiring has been maintained.



### Notes:

1. Be sure power supply agrees with equipment nameplate.
2. Power wiring and grounding of equipment must comply with local codes.
3. Low voltage wiring to be No. 18 AWG minimum conductor.
4. "----" The electric auxiliary heat connection.

Figure 4-2 Schematic diagram for control wiring connection

## 4.3 Grounding

### WARNING

The unit must be permanently grounded.

Failure to do so can result in electrical shock causing personal injury or death.

- Grounding may be accomplished by grounding metal conduit when installed in accordance with electrical codes to the unit cabinet.
- Grounding may also be accomplished by attaching ground wire(s) to ground lug(s) provided in the unit wiring compartment.
- Use of multiple supply circuits require grounding of each circuit to lug(s) provided in the unit.

## 4.4 Electrical Data

Model	Voltage-Phase-Hz	Power Supply Wiring Gauge	Motor HP	Motor Steps	Minimum Circuit AMPS.	Fuse (A)
36	208/230-1Ph-60Hz	14	1/2	5	5.1	15
60	208/230-1Ph-60Hz	14	3/4	5	7.5	15

## 4.5 Electric Heater Data

Heater Kit Model	AHU Model	Electric Heater(kW)	MIN. Circuit Ampacity		MAX. Fuse or Breaker (HACR) Ampacity		Fan speed				
			240	208	240	208	1	2	3	4	5
E-EHK05	36	5	29.7	26.2	30	30	●	●	●	●	●
E-EHK10		10	55.8	48.8	60	50	×	×	×	●	●
E-EHK15		5+10	26.1+55.8	22.6+48.8	30+60	25+50	×	×	×	●	●
E-EHK05	60	5	33.6	30.1	35	35	×	×	●	●	●
E-EHK10		10	59.6	52.7	60	60	×	×	●	●	●
E-EHK15		5+10	26.1+59.6	22.6+52.7	30+60	25+60	×	×	●	●	●
E-EHK20		10+10	52.1+59.6	45.2+52.7	60+60	50+60	×	×	×	●	●

● means available    × means unavailable

Heater kits are suitable for air handler multiple position installation.

### Safety Cautions

All electric work must be performed by qualified personnel.

EHK series is designed and approved to be installed in the G series air handlers.

- Check the heater label to confirm suitable KW selection based on room load under lowest temperature ambient.
- Inspect all porcelain in insulators for breakage and the intact of heater element wire. Contact local distributor immediately if there is any occurred damage.



### Warning

- Disconnect all external power supplies before performing installation and service. Turn off accessory heater power switch if applicable. Failure to do so may cause serious injury.
- EHK must be properly grounded and use copper supply wires.
- Make sure to follow national electric code and local regulations.
- When installing it in an enclosed area such as a garage, heater elements should have a minimum clearance of 18" from the floor to insure the proper ventilation.

**WARNING**

Disconnect all power to unit before installing or servicing. More than one disconnect switch may be required to de-energize the equipment. Hazardous voltage can cause severe personal injury or death.

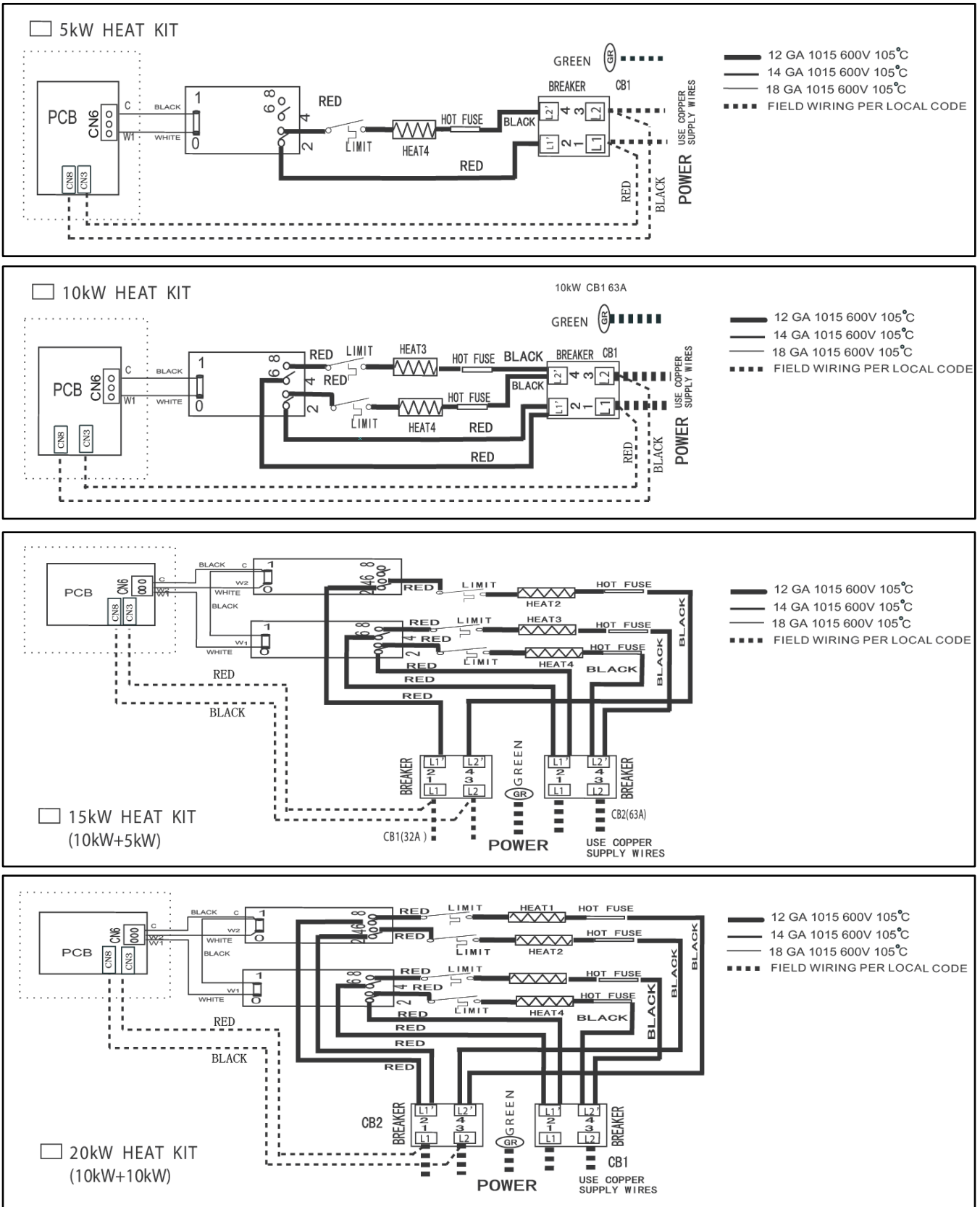

Figure 4-3 Wiring diagram for electric heater

## 5. Airflow Performance

Airflow performance data is based on cooling performance with a coil and no filter in place.

Check the performance table for appropriate unit size selection. External static pressure should stay within the minimum and maximum limits shown in the table below in order to ensure proper.

Model Number	Motor Speed		CFM (Watts)										
			External Static Pressure-Inches W.C.[KPa]										
			0 [0]	0.1 [.02]	0.16 [.04]	0.2 [.05]	0.3 [.07]	0.4 [.10]	0.5 [.12]	0.6 [.15]	0.7 [.17]	0.8 [.20]	
36	Tap(5)	SCFM	1452	1403	1356	1343	1287	1214	1144	1085	1022	968	
		Watts	253	264	269	271	284	296	303	313	324	329	
	Tap(4)-factory	SCFM	1255	1203	1155	1150	1062	995	920	854	797	719	
		Watts	170	182	190	193	201	212	221	229	239	244	
	Tap(3)	SCFM	1109	1050	986	985	897	841	841	766	702	617	
		Watts	126	136	142	147	154	164	170	180	187	195	
	Tap(2)	SCFM	1020	907	838	818	733	673	586	520	-	-	
		Watts	103	98	108	109	114	124	129	139	-	-	
	Tap(1)	SCFM	962	807	660	627	551	450	380	296	-	-	
		Watts	90	80	72	71	79	83	93	96	-	-	
	60	Tap(5)	SCFM	2054	2015	1970	1947	1928	1886	1846	1804	1742	1654
			Watts	470	495	512	518	528	542	553	569	567	548
Tap(4)-factory		SCFM	1883	1840	1797	1783	1754	1712	1670	1622	1579	1541	
		Watts	367	388	406	411	420	422	445	454	466	479	
Tap(3)		SCFM	1721	1674	1625	1582	1566	1528	1484	1443	1401	1345	
		Watts	289	305	319	327	330	341	353	365	378	387	
Tap(2)		SCFM	1515	1463	1407	1386	1358	1308	1262	1215	1153	1073	
		Watts	205	218	229	235	239	251	263	276	285	301	
Tap(1)		SCFM	1337	1265	1208	1156	1148	1095	984	955	963	789	
		Watts	145	157	167	173	178	186	197	212	225	235	

Shaded boxes represent airflow outside the required 300-450cfm/ton.

### NOTES:

Airflow based upon cooling performance at 230V with no electric heat and no filter.

Airflow at 208V is approximately the same as 230V because the multi-tap ECM motor is a constant torque motor. The torque doesn't drop off at the speeds in which the motor operates.

The air distribution system has the greatest effect on airflow. For this reason, the contractor should use only industry-recognized procedures to finish ductwork.

Heat pump systems require a specified airflow. Each ton of cooling requires between 300 and 450 cubic feet of air per minute (CFM). Duct design and construction should be carefully done. System performance can be lowered dramatically through bad planning or workmanship.

Air supply diffusers must be selected and located carefully. They must be sized and positioned to deliver treated air along the perimeter of the space. Return air grilles must be properly sized to carry air back to the blower as well. Failure to follow these may cause abnormal noise and drafts.

The installers should balance the air distribution system to ensure proper quiet airflow to all rooms in the home. This ensures a comfortable living space. An air velocity meter or airflow hood can give a reading of system CFM.

## 6. Ductwork

Field ductwork must comply with the National Fire Protection Association NFPA 90A, NFPA 90B and any applicable local ordinance.

### WARNING

Do not, under any circumstances, connect return ductwork to any other heat producing device such as fireplace insert, stove, etc. Unauthorized use of such devices may result in fire, carbon monoxide poisoning, explosion, personal injury or property damage.

Sheet metal ductwork run in unconditioned spaces must be insulated and covered with a vapor barrier. Fibrous ductwork may be used if constructed and installed in accordance with SMACNA Construction Standard on Fibrous Glass Ducts. Ductwork must comply with National Fire Protection Association as tested by U/L Standard 181 for Class I Air Ducts. Check local codes for requirements on ductwork and insulation.

- Duct system must be designed within the range of external static pressure the unit is designed to operate against. It is important that the system airflow be adequate. Make sure supply and return ductwork, grilles, special filters, accessories, etc. are accounted for in total flow resistance. Refer to the airflow performance table in this manual.
- Design the duct system in accordance with "ACCA" Manual "D" Design for Residential Winter and Summer Air Conditioning and Equipment Selection. Latest editions are available from: "ACCA" Air Conditioning Contractors of America, 1513 16th Street, N.W., Washington, D.C. 20036. If duct system incorporates flexible air duct, be sure that the pressure drop Information (straight length plus all turns) shown in "ACCA" Manual "D" is accounted for in system.
- Supply plenum is attached to the 3/4" duct flanges supplied with the unit. Attach flanges around the blower outlet.
- Secure the supply and return ductwork to the unit flanges, using proper fasteners for the type of duct used and tape the duct-to-unit joint as required to prevent air leaks.

### IMPORTANT

If an elbow is included in the plenum close to the unit, it must not be smaller than the dimensions of the supply duct flange on the unit.

The front flange on the return duct connected to the blower casing must not be screwed into the area where the power wiring is located. Drills or sharp screw points can damage insulation on wires located inside unit.

## 7. Pipe Connections

Keep the coil connections sealed until refrigerant connections are made. Refer to condensing unit installation instructions for details on pipe size and insulation.

- Coil is shipped with Nitrogen. Evacuate the system before charging with refrigerant.
- Make sure the refrigerant pipes layout do not block service access.
- Purge the refrigerant pipes and indoor coil with dry nitrogen while brazing.
- Use a wet rag or an approved heat paste to protect the TXV sensing bulb during the brazing process.

### Condensate Drain Connection

1. Use a thin layer of Teflon paste, silicone or Teflon tape when making drain fitting connections.
2. Do not over tighten fittings resulting in splitting pipe connections on the drain pan.

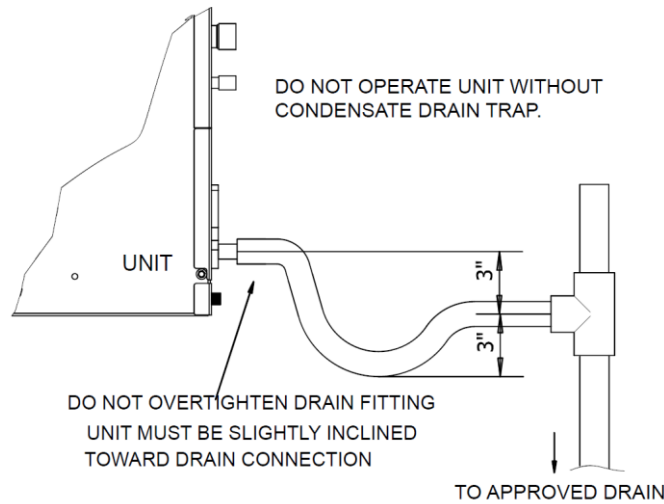

Figure 7-1 Condensate drain trap

- Make sure the drain pipes layout do not block service access. Minimum clearance of 24 inches is required for filter, coil or blower removal and service access.
- Ensure the unit is level or pitched slightly toward primary drain connection so that water will drain smoothly from the pan. All horizontal drain pipes must be pitched downward away from the unit a minimum of 1/8" per foot of line to ensure proper drainage.
- Do not reduce drain pipe size less than connection size provided on condensate drain pan.
- Do not connect condensate drain pipe to a closed or open sewer pipe.
- The drain pipe should be insulated where necessary to prevent sweating and damage due to condensate forming on the outside surface of the line.
- Make provisions for disconnecting and cleaning of the primary drain pipe if it become necessary. Install a 3-inch trap in the primary drain pipe as close as possible to the unit. Make sure that the top of the trap is below connection to the drain pan to allow complete drainage of pan.
- Auxiliary drain pipe should be connected to a place where it will be noticeable. Homeowner should be warned that a problem exists if water begins running from the auxiliary drain pipe.
- Test condensate drain pan and drain pipe after installation is complete. Pour enough water into drain pan, make sure that the drain pan is draining completely, no leaks are found in drain pipe fittings, and no water is draining from the termination of the primary drain pipe.

## 8. Air Filter

Filter application and replacement are critical to airflow, which may affect the heating and cooling system performance. Reduced airflow can shorten the life of the system's major components, such as motor, heat relays, evaporator coil or compressor. Units should be sized for a maximum of 300 feet/min. air velocity or what is recommended for the filter type installed.

Ensure the air flow is in the range of 300~450CFM if adding high efficiency filters or electronic air filtration systems. Note that the overall performance and efficiency of the unit will be reduced because of pressure drop by filters.

### IMPORTANT

Do not double filter the return air duct.

Do not filter the supply air duct which will change the performance of the unit and reduce airflow .

### WARNING

Do not operate the system without filters. A portion of the dust suspended in the air may temporarily lodge in the duct. Any circulated dust particles could be heated and charred by contact with the air handler elements. This residue could soil ceilings, walls, drapes, carpets and other articles in the house. Soot damage may occur without filters in place when certain types of candles, oil lamps or standing pilots are burned.

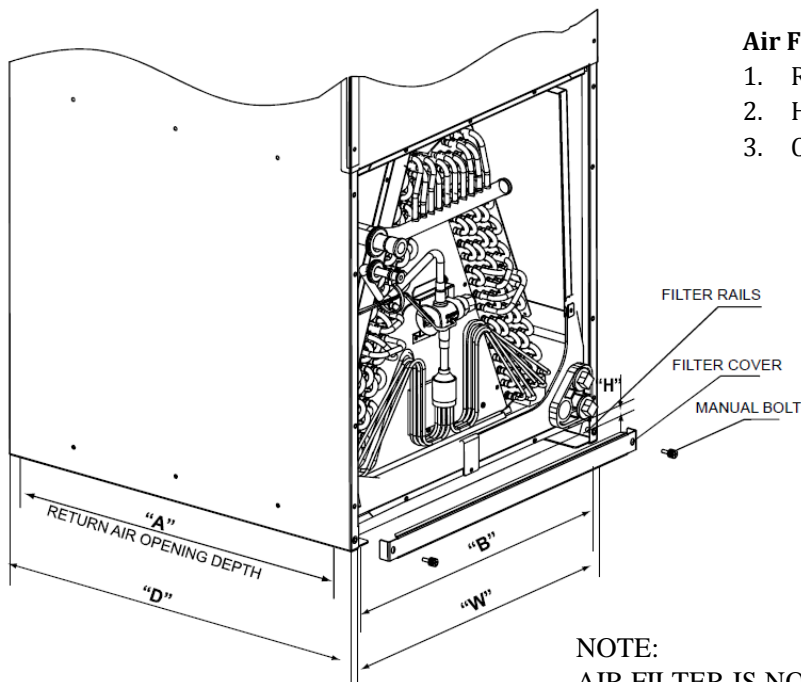

### Air Filter Clean/Replacement

1. Remove bolts to take the filter cover away.
2. Hold the edge of the air filter and extract it out .
3. Clean the air filter or use a new one to replace.

NOTE:  
AIR FILTER IS NOT FACTORY INSTALLED.

Figure 8-1 Filter installation and clean

Model	Dimensions(in.)					
	Filter Size	W	D	H	A	B
36	18 x 20	18-11/32	21-5/8	1	20-3/4	16-1/4
60	20 x 22	20-3/4	24	1	23	18-3/4



## 9. TXV Adjustment

To keep the best Ecoer Smart Inverter (ESI) systems' performance and reliability, be sure liquid line sub-cooling (SC) and compressor suction superheat (SH) meet our requirements.

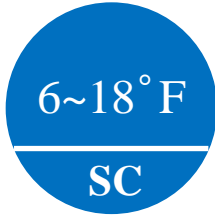

**Target values  
in cooling mode**



- If the LED displays "--" in AUTO charge mode for more than 20 minutes, stop charging and use a wrench to **clockwise** the TXV to ensure SH is no less than 7°F.
- In case that the cooling performance is abnormal due to improper superheat (i.e. SH >20°F). Adjust the system according to
  1. Activate AUTO charge mode from outdoor condensing unit to fix compressor frequency (RPS) by press BS4 for 5 seconds on PCB. Run the system for 15~20 minutes and check refrigerant coefficient number from LED display or ESS Pro App, **add refrigerant until you get 0.6**.
  2. Adjust TXV opening to allow more refrigerant flow into indoor coil if SH is still larger than 20°F. Open the front panel of the indoor unit, then remove the TXV nut and use a wrench to **counterclockwise** the TXV until SH ≤ 20°F.

### NOTE:

**Maintain a minimum of 5 minutes' operation** after every refrigerant charge or TXV opening adjustment, then check live SC and SH from Ecoer Smart Service Mobile App.

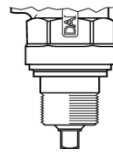
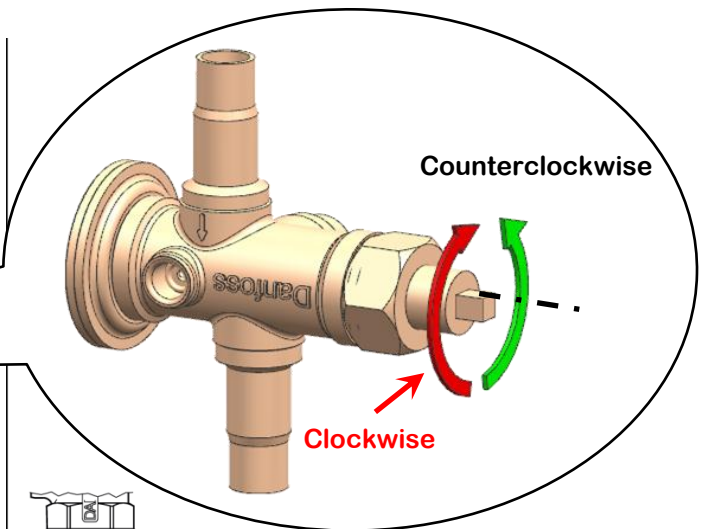
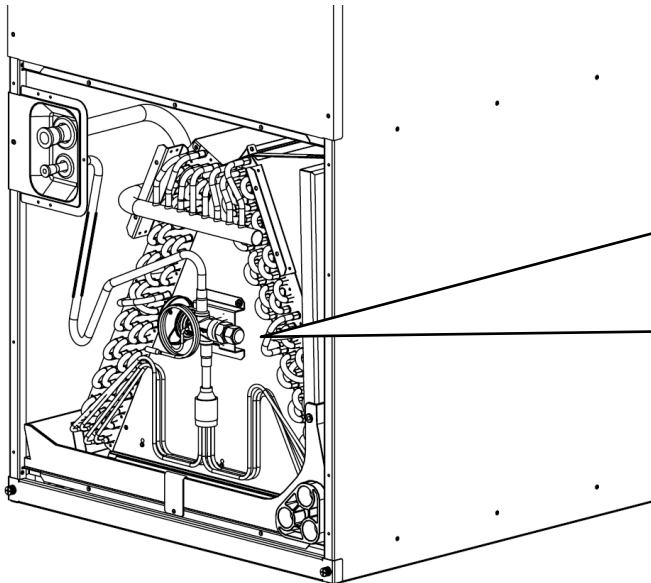

Hex = 19 mm / 3/4 in.

Torque = 10 Nm / 7 ft-lb

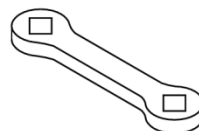

Δ SH / 1 turn / 360° ≈

R410A: 0.6°C / 1.1°F

### Remember:

Put back the panel after TXV adjusted.